



**PCVS-1 Stock No. 1010107**

**PCVS-2 Stock No. 1010207**

**UL and CSFM Listed, FM Approved, NYMEA Accepted, CE Marked**

**Dimensions:** 4.75"L x 2.25"W x 7.2"H (stem extended)  
12,1cm L x 5,7cm W x 18,3cm H

**Weight:** 1.35 lb. (0,61 kg.)

**Enclosure:** Cover - Die-cast  
Finish - Red Spatter Enamel  
Base - Die Cast Zinc  
All parts have corrosion resistant finishes.

**Cover Tamper:** Tamper Resistant Screws,  
Optional cover tamper kit available

**Mounting:** 1/2" NPT

**Contact Rating:** PCVS-1: One set of SPDT (Form C)  
PCVS-2: Two sets of SPDT (Form C)  
15.00 Amps at 125/250VAC  
2.50 Amps at 30VDC resistive

**Environmental Limitations:** -40°F to +140°F (-40°C to 60°C)  
**NEMA 4 and NEMA 6P Enclosure (IP67) when used with appropriate watertight conduit fittings.**  
Indoor or Outdoor Use (Not for use in hazardous locations. See bulletin no. 5400694 PIVS-U-EX for hazardous locations.)

**Conduit Entrances:** Two knockouts for 1/2" conduit provided.

**Service Use:**

Automatic Sprinkler	NFPA-13
One or two family dwelling	NFPA-13D
Residential occupancy up to four stories	NFPA-13R
National Fire Alarm Code	NFPA-72

The Model PCVS is a weather proof and tamper resistant switch for monitoring the open position of fire sprinkler control valves of the post indicator, butterfly and other types. Depending on the model, one or two SPDT (Form C) contacts are provided which will operate when the valve position is altered from an open state.

The unit mounts in a 1/2" NPT tapped hole in the post indicator or butterfly valve housing. The device is engaged by the indicating assembly of the post indicator or the operating mechanism of the butterfly valve, actuating switch(es) when the valve is fully open. The unit should be installed where it is accessible for service.

The cover is held in place by two tamper resistant screws that require

a special tool to remove. The tool is furnished with each device and should be left with the building owner or responsible party. Replacement or additional cover screws and hex keys are available. See ordering information.

**OPTIONAL COVER TAMPER SWITCH:** A field installable cover tamper switch is available as an option which may be used to indicate removal of the cover. See ordering information.

**TESTING:** The PCVS and its associated protective monitoring system should be tested in accordance with applicable NFPA codes and standards and/or the authority having jurisdiction (manufacturer recommends quarterly or more frequently).

**ORDERING INFORMATION**

<b>MODEL</b>	<b>DESCRIPTION</b>	<b>STOCK NO.</b>
PCVS-1	Potter Control Valve Switch (single switch)	1010107
PCVS-2	Potter Control Valve Switch (double switch)	1010207
--	Cover Screw	5490344
--	Hex Key for Cover Screws and Installation Adjustments	5250062
PBK-S	Pratt Butterfly Valve Kit - Up to 12" (300mm)	0090133
PBK-L	Pratt Butterfly Valve Kit - 14" (355mm) and Up	0090132
PVK	Pratt Valve Kit	1000060
--	Optional Cover Tamper Switch Kit	0090131
KBK	Kennedy Butterfly Valve Kit	0090143

For pressure reducer type valve installation kits (if required) contact valve manufacturer.

FIG. 1 DIMENSIONS

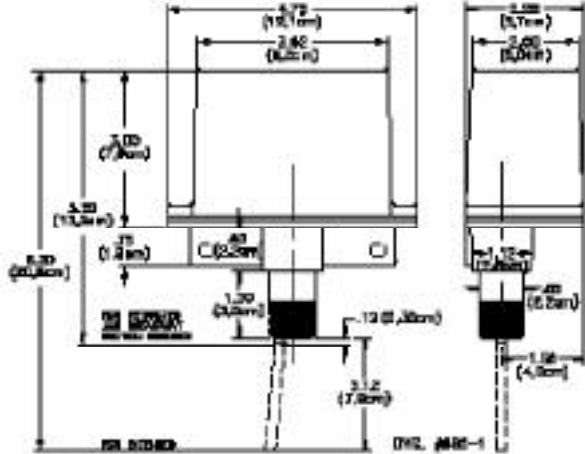
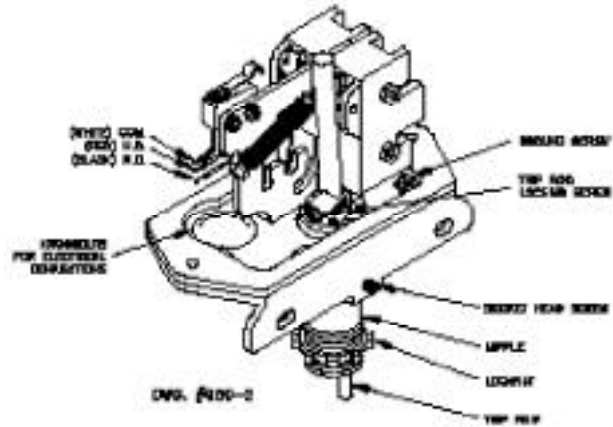

FIG. 2 PARTS



### TYPICAL INSTALLATIONS ON POST INDICATOR VALVE HOUSINGS (SEE FIGS. 3 THRU 6)

Refer to Fig. 2 for the location of parts described in the following instructions.  
**NOTE:** If the sprinkler system is in service the owner or authorized representative should be notified, before any work is done on the system, that the valve controlling the water supply to the system may be closed for periods of time during the installation and testing of this device, resulting in all or portions of the system being inoperative during these periods.  
 If the system is not in service and valve is closed, be sure that opening the valve will not allow any unwanted water flow due to openings in the system, such as heads off, broken or incomplete piping, etc.

1. Position the valve to fully open ("OPEN" should appear in the window of the housing). Partially close the valve while observing the direction that the target assembly moves. Reopen the valve.  
 If the valve housing is predrilled with a 1/2" NPT for installation of a monitoring switch, remove the 1/2" plug and fully open the valve. Make sure that "OPEN" appears in the window of the housing. GO TO STEP NO. 6.
2. Remove the head and target assembly (consultation with valve manufacturer is recommended).
3. If the target assembly moved up as the valve was closed, measure the distance from the bottom of the head to the lower part of the target assembly that will contact the trip rod of the PCVS (see Fig. 3). This is usually a plate or bar on the target assembly, on a side adjacent to the "OPEN/SHUT" plates. Subtract 1/8" from the measurement.  
 If the target moved down as the valve was closed, measure the distance from the bottom of the head to the upper portion of the target assembly that will contact the trip rod of the PCVS (see Fig. 4). Add 1/8" (3,2mm) to this measurement.
4. Mark the housing at the proper location. Using a 23/32" (18,2mm) drill bit, drill and then tap a 1/2" NPT in the housing on the side that coincides with the portion of the target assembly that will engage the trip rod of the PCVS.
5. Replace the head and target assembly.
6. Loosen the socket head screw that holds the nipple in the PCVS and remove the nipple.
7. Screw the locknut that is provided onto the nipple.
8. Screw the nipple into the 1/2" NPT hole in the valve housing - hand tighten. Tighten the locknut against the valve housing to secure the nipple firmly in place.

9. Insert a scale or probe thru the nipple to measure the distance from the open end of the nipple to the target assembly. Subtract 1/2" (12,5mm) from this measurement.  
**NOTE:** In some cases, it may be necessary to attach an angle bracket to the target assembly to engage the PCVS trip rod.
10. Using the special tool provided, loosen the two cover screws and remove the cover from the PCVS.
11. Loosen the locking screw that holds the trip rod in place and adjust the rod length, from the end of the collar to the end of the rod, using the dimension determined in Step 9. Tighten the locking screw to hold the rod in place.  
**NOTE:** If trip rod length is excessive, loosen the locking screw and remove the trip rod from the trip lever. Using pliers, break off the one (1) inch long notched section (see Fig. 7). Reinstall trip rod and repeat Step 11 procedure.
12. Partially close the valve (3 to 4 revolutions of the handle/hand wheel).
13. Slide the PCVS unit as far as possible onto the nipple, observing which direction the rod will move when the valve is closed. Orient the device to actuate the switches when the valve is open. Tighten the socket head screw in the collar.
14. Carefully open the valve to the fully open position. As the target moves to the open position it should engage the trip rod and actuate the switch(es). There should be a minimum overtravel of 1/2 revolution of the handle/hand wheel after the switch(es) actuate (a continuity meter connected to each set of contacts is one method that could be used to determine this).
15. Slowly close the valve. The switch must operate during the first two revolutions of the handle/hand wheel or during 1/5 of the travel distance of the valve control apparatus from its normal condition.  
**NOTE:** Small adjustments of the target position may be necessary (consultation with valve manufacturer is recommended).
16. Complete the required electrical wiring, connections and tests. The valve should be operated through the entire cycle of fully closed and fully open to determine the integrity of the PCVS installation and the signaling system. Check that all electrical and mechanical connections are secure.
17. When the installation and testing are complete, return valve to its proper position.
18. Alternative installation for other post indicator valve housing shown in Fig. 5 and 6.

FIG. 3

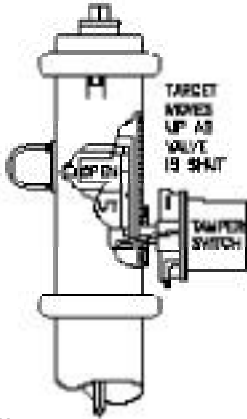

FIG. 4

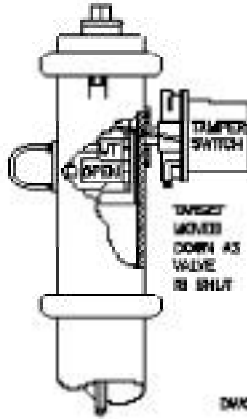

FIG. 5

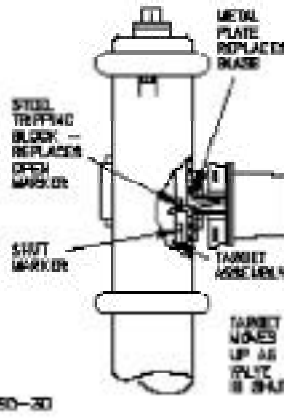
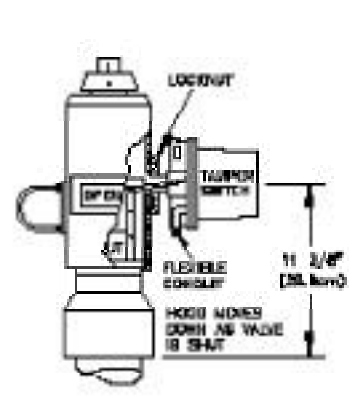

FIG. 6



**Notes:**

1. Subject to the approval of the "authority having jurisdiction" the alternate method of installation shown in Fig. 5 may be used. In this method, one of the glass windows of the housing is replaced with a 1/4" thick metal plate that is cut to fit in place of the glass and drilled and tapped to receive the 1/2" NPT pipe nipple. In some cases it may be necessary to attach an angle bracket to the target assembly to engage the PCVS trip rod.
2. If the target is stationary and a hood arrangement is used, such as is shown in Fig. 6, the hood must be drilled with a 23/32" drill and tapped with a 1/2" NPT. The center line of this hole should be 1/8" below the portion of target assembly that strikes the PCVS trip rod. The 11 3/8" dimension shown is for a Clow Valve. Flexible conduit must be used for this type of installation.

**TYPICAL INSTALLATION ON A BUTTERFLY VALVE (SEE FIGS. 9 AND 10)**

Refer to Fig. 2 for location of parts described in the following instructions:

- B1. Remove the 1/2" NPT plug from the gear operator case.
- B2. Loosen the set screw that holds the nipple in the PCVS and remove the nipple.
- B3. Screw the locknut that is provided onto the nipple.
- B4. Screw the nipple into the 1/2" NPT hole in the gear operator - hand tighten. Tighten the locknut against the case, to secure the nipple firmly in place.
- B5. Partially close the valve (3 or 4 revolutions of the hand wheel or crank).
- B6. Using the special tool provided, loosen the two cover screws and remove the cover from the PCVS.
- B7. Loosen the locking screw that holds the trip rod in place. Estimate trip rod length required and extend slightly past that point. Slide the PCVS unit as far as possible onto the nipple, observing which direction the rod will move when the valve is closed. Orient the device to actuate switches when valve is open.  
NOTE: If trip rod length is excessive, loosen the locking screw and remove the trip rod from the trip lever. Using pliers, break off the one (1) inch long notched section (see Fig. 7). Reinstall trip rod and repeat Step B7 procedure.
- B8. Remove device from nipple and withdraw trip rod 1/32" (0,80mm) (this dimension is important). Tighten the locking screw to hold the rod in

place. Re-install the device on the nipple. Tighten the screw in the collar against the nipple.

NOTE: In some cases it may be necessary to remove the gear box cover to ensure correct operation (consultation with the valve manufacturer is recommended).

- B9. Carefully open the valve to its full open position, as the boss on the gear hub moves to the open position it must engage the PCVS trip rod and actuate the switch(es). There should be a minimum overtravel or revolution of the crank or hand wheel after the switch(es) actuate (a continuity meter connected to each set of contacts is one method that could be used to determine this).  
NOTE: Slight adjustment of gear stops may be necessary to prevent overtravel of the trip rod (consultation with valve manufacture is recommended).
- B10. Carefully close the valve. The switch(es) must operate during the first two revolutions of the crank or hand wheel or during 1/5 of the travel distance of the valve control apparatus from its normal condition.
- B11. Complete the required electrical wiring, connections and tests. The valve should be operated through the entire cycle of fully closed and fully open to determine the integrity of the PCVS installation and signaling system.  
Check that all electrical and mechanical connections are secure.
- B12. When the installation and testing are complete, return valve to its proper position.

FIG. 7 BREAKING EXCESSIVE ROD LENGTH



SWITCH TERMINAL CONNECTIONS CLAMPING PLATE TERMINAL FIG. 8



**CAUTION:**

An uninsulated section of a single conductor should not be looped around the terminal and serve as two separate connections. The wire must be severed, thereby providing supervision of the connection in the event that the wire becomes dislodged from under the terminal.

ITT GRINNELL/KENNEDY INDICATING BUTTERFLY VALVE

FIG. 8

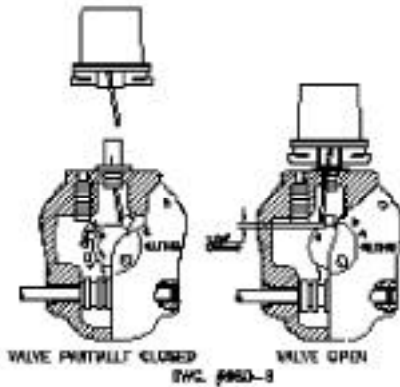

DRESSER INDICATING BUTTERFLY VALVE

FIG. 10

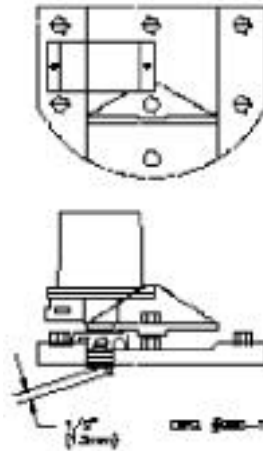

TYPICAL PRESSURE REDUCER TYPE VALVE INSTALLATION

FIG. 11

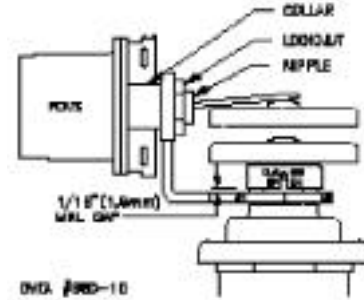

This figure shows the Model PCVS mounted on the valve yoke, with a bracket supplied by the valve manufacturer, to supervise a pressure reducer type valve.  
Note: This application is subject to the approval of the authority having jurisdiction.

PBK - PRATT IBV BUTTERFLY VALVE KIT

FIG. 12

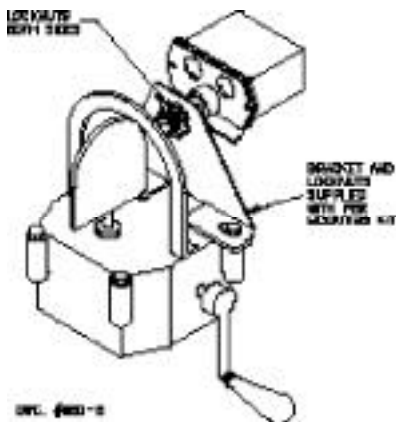

MODEL PBK-L  
Stock No. 0090132  
(MDT-4S Actuator)

MODEL PBK-M  
Stock No. 0090146  
(MDT-3S Actuator)

MODEL PBK-S  
Stock No. 0090133  
(MDT-2S Actuator)

Pratt Butterfly Valve Kit as used to mount a PCVS on a Pratt Model IBV Valve.

Kits contain: Bracket, nuts and instructions

Note: This application is subject to the approval of the authority having jurisdiction.

PVK - PRATT PIVA POST INDICATOR VALVE KIT (STOCK NO. 1000060)

FIG. 13

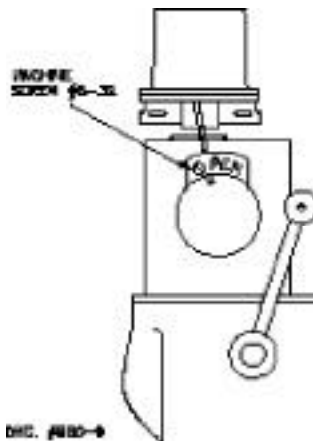

Pratt Valve Kit as used to mount a PCVS on a Pratt Model PIVA Valve.

Kit contains: Instructions, template, screw and nut.

Note: This application is subject to the approval of the authority having jurisdiction.

TYPICAL ELECTRICAL CONNECTIONS

Please Note: This device should be wired in accordance with the applicable parts of the National Electrical Code, all state and local codes, applicable NFPA Standards and the requirements of the authority having jurisdiction.

FIG. 14

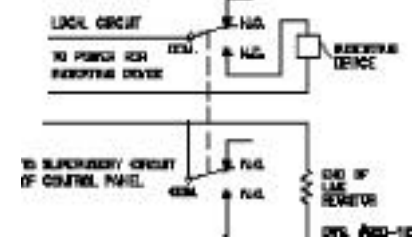

Contacts shown in normal (valve open) condition.

TYPICAL SWITCH ACTION

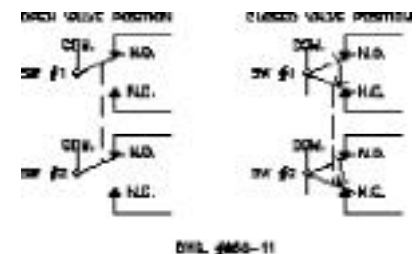

Switches Shown in Valve Open Position