

3M™ Pak 100 Wiremount Plug

.100" × .100"

4600 Series

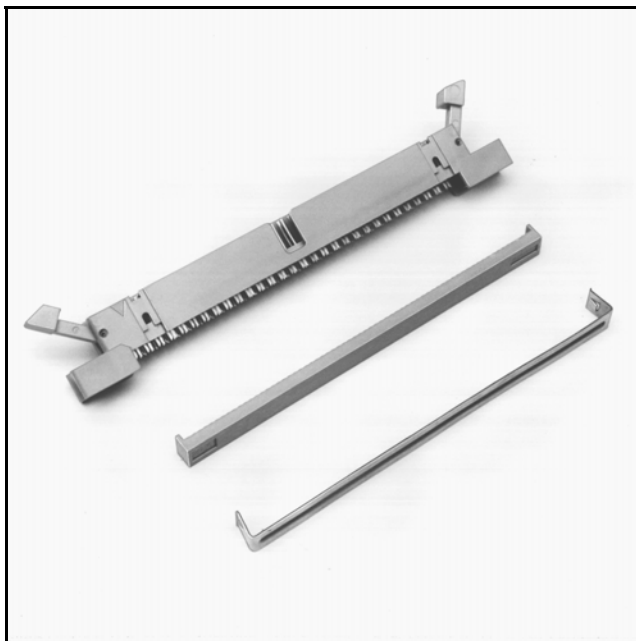

- Shrouded to protect against physical and chemical pin damage
- Open or closed end covers available
- Optional ejector latches
- Accepts flat cable or discrete wire
- Military (with 3518 polarizing key) and centerbump polarization available
- Optional mounting flanges
- RoHS* compliant

Date Modified: February 28, 2005

TS-0086-15
Sheet 1 of 4

Physical

Insulation

Material: Glass Filled Polyester (PBT)
Flammability: UL 94V-0
Color: Gray

Contact

Material: Copper Alloy

Plating:

Underplating and U-Slot: 100 μ " [2.54 μ m] Nickel - QQ-N-290, Class 2
Wiping Area: 30 μ " [0.76 μ m] Gold - MIL-G-45204, Type II, Grade C
Wire Accommodation: 26 & 28 AWG Solid & Stranded

Marking: 3M Logo, Part Identification Number, and Contact Position Numbers

Electrical

Current Rating: 1 A

Insulation Resistance: $> 1 \times 10^9 \Omega$ at 500 VDC

Withstanding Voltage: 1000 Vrms at Sea Level

Environmental

Temperature Rating: -55°C to +120°C

UL File No.: E68080

*RoHS = Directive 2002/95/EC,
Restriction of the Use of Certain Hazardous Substances in Electrical and Electronic Equipment

3M™ Pak 100 Wiremount Plug

.100" × .100"

4600 Series

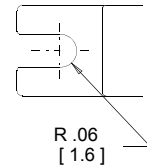
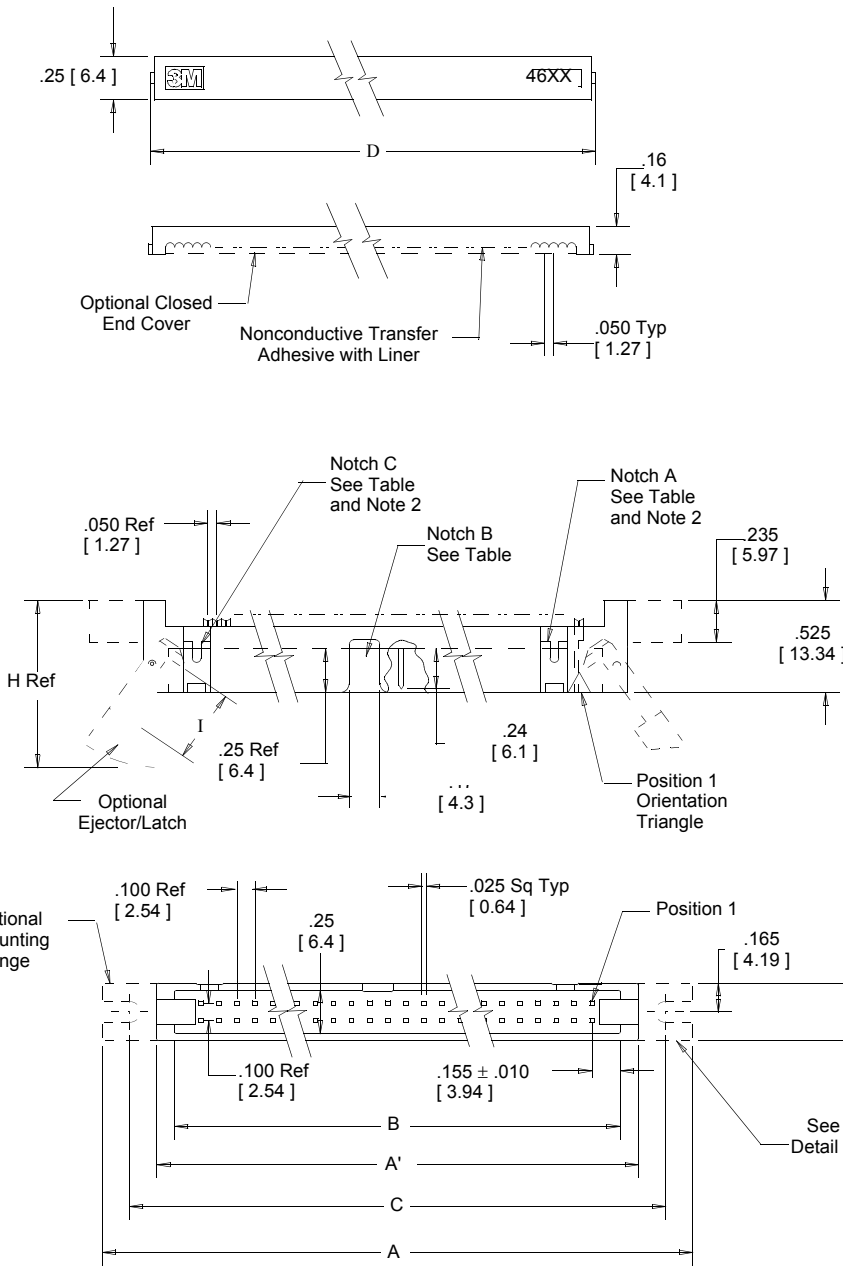

Slotted Mounting Flange
46XX-XXX0

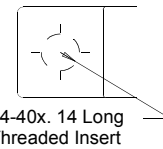

Threaded Mounting Flange
46XX-XXX5
Detail A

Inch [mm]

Tolerance Unless Noted			
	.0	.00	.000
inch	±.1	±.01	±.005

[] Dimensions for Reference Only



Ordering Information

46XX-XXXX

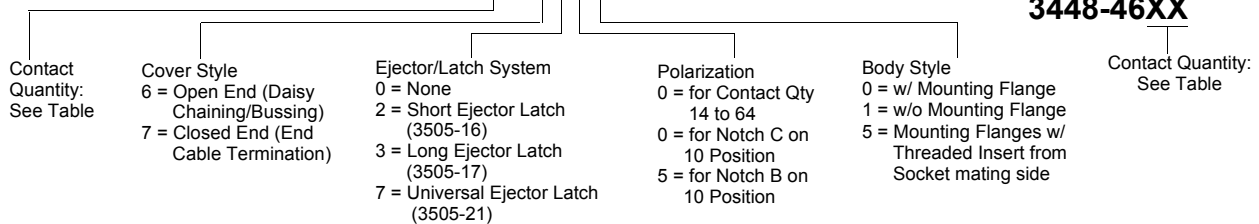

Strain Relief
(Order Separately)
3448-46XX

Assembly tools: 3640 press (or equivalent), 3443-96 locator plate, 3442-9 platen.

TS-0086-15
Sheet 2 of 4

3M™ Pak 100 Wiremount Plug

.100" × .100"

4600 Series

Table 1							
Contact Quantity	Dimensions						Polarizing Notches Provided
	A	A'	B	C	D	E	
10	1.50 [38.1]	0.90 [22.9]	0.71 [18.0]	1.20 [30.5]	0.77 [19.6]	0.85 [21.7]	B or C (See Note 1)
14	1.70 [43.2]	1.10 [27.9]	0.91 [23.1]	1.40 [35.6]	0.97 [24.6]	1.05 [26.8]	BC
16	1.80 [45.7]	1.20 [30.5]	1.01 [25.7]	1.50 [38.1]	1.07 [27.2]	1.15 [29.3]	ABC
20	2.00 [50.8]	1.40 [35.5]	1.21 [30.7]	1.70 [43.2]	1.27 [32.3]	1.35 [34.4]	ABC
24	2.20 [55.9]	1.60 [40.6]	1.41 [35.8]	1.90 [48.3]	1.47 [37.3]	1.55 [39.5]	ABC
26	2.30 [58.4]	1.70 [43.2]	1.51 [38.4]	2.00 [50.8]	1.57 [39.9]	1.65 [42.0]	ABC
30	2.50 [63.5]	1.90 [48.3]	1.71 [43.4]	2.20 [55.9]	1.77 [45.0]	1.85 [47.1]	ABC
34	2.70 [68.6]	2.10 [53.3]	1.91 [48.5]	2.40 [61.0]	1.97 [50.0]	2.05 [52.2]	ABC
36	2.80 [71.1]	2.20 [55.9]	2.01 [51.1]	2.50 [63.5]	2.07 [52.6]	2.15 [54.7]	ABC
40	3.00 [76.2]	2.40 [61.0]	2.21 [56.1]	2.70 [68.6]	2.27 [57.7]	2.35 [59.8]	ABC
50	3.50 [88.9]	2.90 [73.7]	2.71 [68.8]	3.20 [81.3]	2.77 [70.4]	2.85 [72.5]	ABC
60	4.00 [101.6]	3.40 [86.4]	3.21 [81.5]	3.70 [94.0]	3.27 [83.1]	3.35 [85.1]	ABC
64	4.20 [106.7]	3.60 [91.4]	3.41 [86.6]	3.90 [99.1]	3.47 [88.1]	3.55 [90.2]	ABC

Table 2					
Ejector/Latch Option	Part Number	Dimensions			
		F	G	H	I
Short	3505-16	.335 [8.51]	.726 [18.44]	0.92 [23.4]	.41 [10.4]
Long	3505-17	.484 [12.29]	.875 [22.23]	1.07 [27.2]	.56 [14.2]
Universal	3505-21	.484 [12.29]	.809 [20.55]	1.01 [25.65]	.56 [14.2]

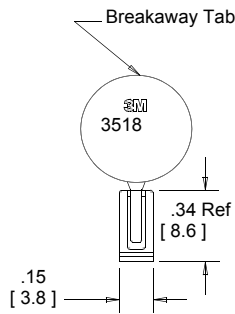

3M Part No 3518

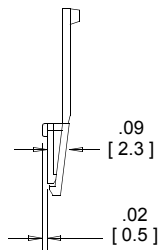

Polarizing Key
(Order Separately)
Material: Gray Glass Filled

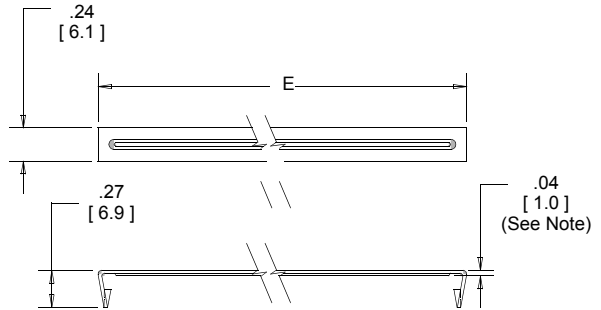

Strain Relief
Material .012" [0.31] Thick
Stainless Steel

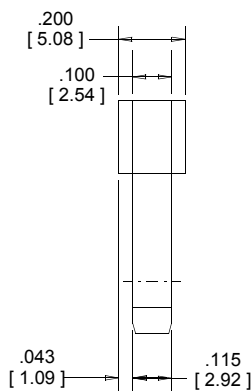

3505-21

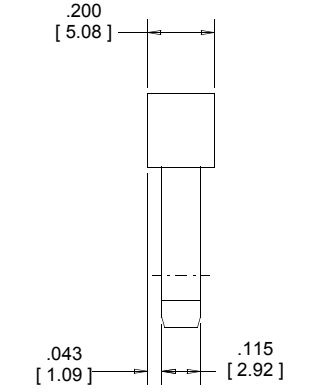

3505-16
3505-17

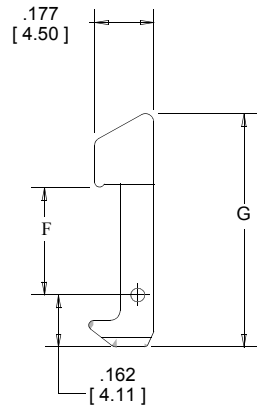

Note:
The distance from the strain relief to the connector is equal to .04 [1.0] plus the cable thickness.

TS-0086-15
Sheet 3 of 4

3M™ Pak 100 Wiremount Plug

.100" × .100"

4600 Series

Table 3

Contact Quantity	3M Part Number Series	Dimension A	Dimension B
10	4610	1.200 [30.48]	0.945 [24.00]
14	4614	1.400 [35.56]	1.145 [29.08]
16	4616	1.500 [38.10]	1.245 [31.62]
20	4620	1.700 [43.18]	1.445 [36.70]
24	4624	1.900 [48.26]	1.645 [41.78]
26	4626	2.000 [50.80]	1.745 [44.32]
30	4630	2.200 [55.88]	1.945 [49.40]
34	4634	2.400 [60.96]	2.145 [54.48]
36	4636	2.500 [63.50]	2.245 [57.02]
40	4640	2.700 [68.58]	2.445 [62.10]
50	4650	3.200 [81.28]	2.945 [74.80]
60	4660	3.700 [93.98]	3.445 [87.50]
64	4664	3.900 [99.06]	3.645 [92.58]

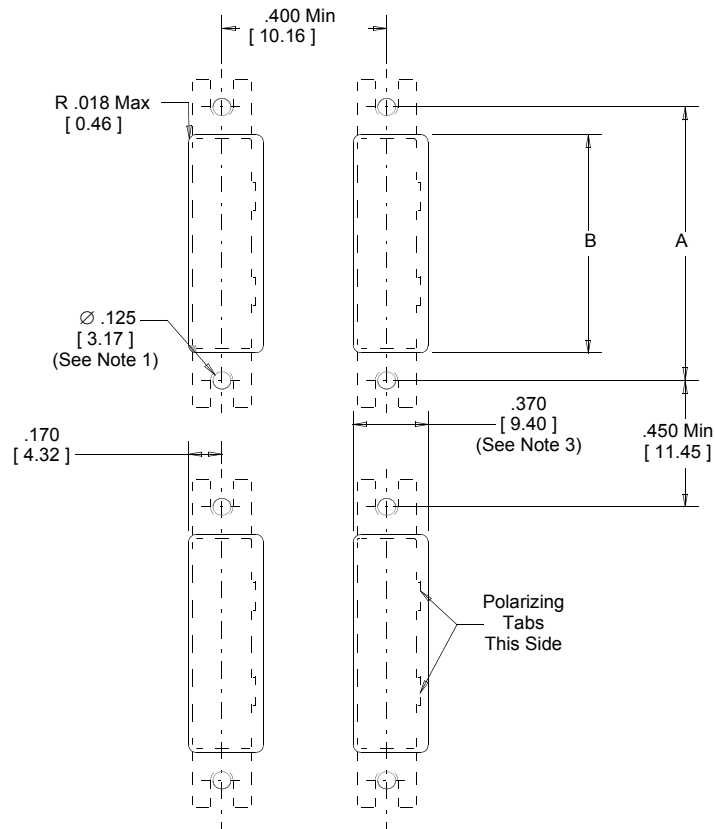

Rear Mount Panel Cutout

Notes:

1. Accepts #4 pan head machine screw.
2. For a rear mount plug connector with Ejector/Latches the recommended maximum panel thickness is $.125$ [3.16].
3. Without polarizing tabs $.340$ [8.64].

TS-0086-15
Sheet 4 of 4

Important Notice

All statements, technical information, and recommendations related to 3M's products are based on information believed to be reliable, but the accuracy or completeness is not guaranteed. Before using this product, you must evaluate it and determine if it is suitable for your intended application. You assume all risks and liability associated with such use. Any statements related to the product which are not contained in 3M's current publications, or any contrary statements contained on your purchase order shall have no force or effect unless expressly agreed upon, in writing, by an authorized officer of 3M.

Warranty; Limited Remedy; Limited Liability.

This product will be free from defects in material and manufacture for a period of 1 year from the time of purchase. **3M MAKES NO OTHER WARRANTIES INCLUDING, BUT NOT LIMITED TO, ANY IMPLIED WARRANTY OF MERCHANTABILITY OR FITNESS FOR A PARTICULAR PURPOSE.** If this product is defective within the warranty period stated above, your exclusive remedy shall be, at 3M's option, to replace or repair the 3M product or refund the purchase price of the 3M product. **Except where prohibited by law, 3M will not be liable for any indirect, special, incidental or consequential loss or damage arising from this 3M product, regardless of the legal theory asserted.**

3M

Electronic Solutions Division

6801 River Place Blvd.
Austin, TX 78726-9000
www.3M.com/esd



Minimum 10%
Post-consumer Fiber

Printed in USA.

© 3M 2005