

PRODUCT NUMBER  
SEE TABLE

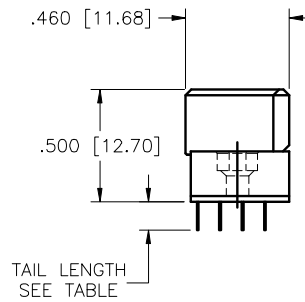

mat'l. code				surface	tolerance	projection	product family
NOTE 3				ISO 1302	ISO 406	ISO 1301	HPC
ltr	ecn no	dr	date	tolerances unless otherwise specified		INCH/MM	title
L	v50348	LSS	6/15/95	angles	.XX±.01/XX±0.3		
M	v90140	HTB	2/16/99	linear	.XXX±.006/XX±0.13	SOLDER TO BOARD, 0 GUIDE PIN	
N	v00258	JWS	1/21/00	0'±2'	.XXX±.0020/XXX±0.051	scale 1:1	dwg no
P	v12267	MEM	9/29/01	dr	D.SHEAFFER	10/7/92	sheet 1 of 3
R	v05-0755	DAI	10/14/05	engr	S.CLARK	10/7/92	size
S	M06-0283	MHT	7/27/06	chr	S.CLARK	10/7/92	A3
T	M08-0280	AGS	9/30/08	appd	S.CLARK	10/7/92	type
sheet	revision	T	T	T			Product Customer Drawing
index	sheet	1	2	3			

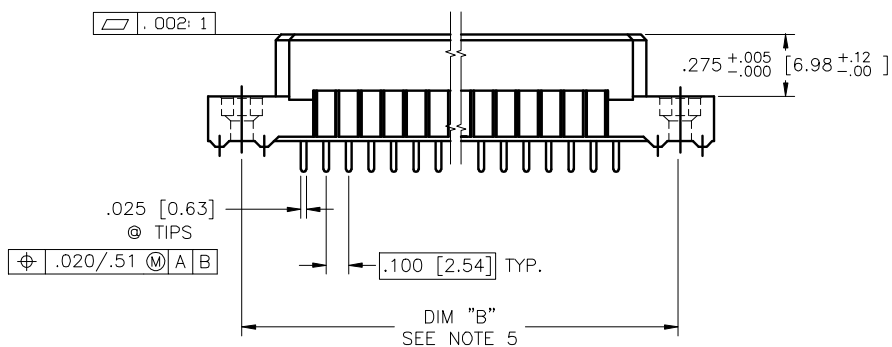
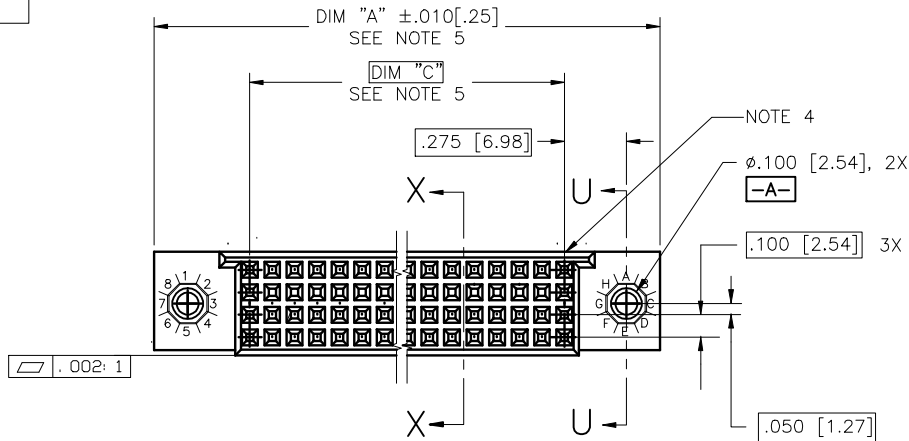

Copyright FCI

form A3

PRODUCT NUMBER  
SEE TABLE

NOTES:

- ①. PRODUCT NUMBERING CODE:  
50388 - X YYY Z LF
- X — LEAD FREE (OPTIONAL)
  - YYY — TAIL LENGTH SEE TABLE
  - Z — NO. OF POSITIONS SEE NOTE 2
  - LF — PLATING SEE TABLE
  - 50388 — BASE NUMBER

- PRODUCT NUMBERING CODE FOR  
SELECT LOAD PARTS:  
50388 - XX YYY
- XX — LEAD FREE (OPTIONAL)
  - YYY — SEQUENCE NUMBER
  - ALWAYS XX
  - BASE NUMBER

- ②. THIS PRODUCT IS CONFIGURED IN SIZES OF 10 THRU 80 COLUMNS IN INCREMENTS OF ONE. i.e.: 10,11,12,13,.....79,80.
- ③. HOUSING MATERIAL: GLASS AND MINERAL FILLED HIGH TEMP. THERMOPLASTIC. FLAME RETARDANT PER UL94V-0. COLOR: BLACK. CONTACT MATERIAL: BeCu
- ④. MANUFACTURE'S NAME, P/N AND LOT CODE TO APPEAR ON THIS SURFACE AS PER BUS-12-108.
- ⑤. LENGTH FORMULAS  
DIM A = .100/2.54 X NO. OF COLUMNS + .75/19.1  
DIM B = .100/2.54 X NO. OF COLUMNS + .45/11.4  
DIM C = .100/2.54 X NO. OF COLUMNS - .10/2.5
- ⑥. THIS PRODUCT (WITH "LF" SUFFIX) MEETS EUROPEAN UNION DIRECTIVES AND OTHER COUNTRY REGULATIONS AS DESCRIBED IN GS-22-008.
- ⑦. THIS HOUSING WILL WITHSTAND EXPOSURE TO 260° C PEAK TEMPERATURE FOR 10-30 SECONDS IN A CONVECTION, INFRA-RED OR VAPOR PHASE REFLOW OVEN.
- ⑧. PLATING OPTION:  
MAY BE EITHER GOLD OR GXT PLATED AT MANUFACTURER'S OPTION.

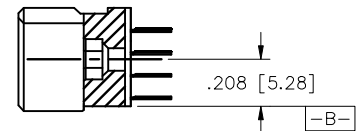
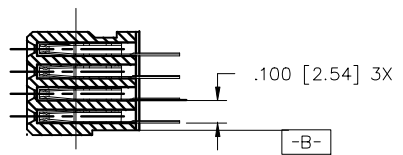

SECTION X-X

SECTION U-U

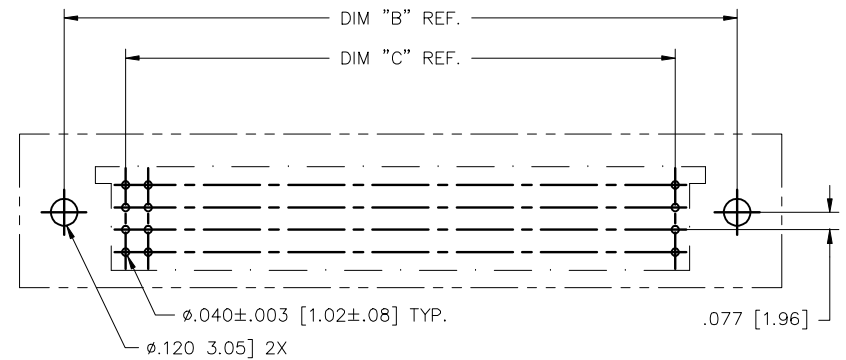

RECOMMENDED PCB LAYOUT  
(ALL HOLES LOCATED ON .100/2.54 GRID  
UNLESS OTHERWISE SPECIFIED)

mat'l. code		surface		tolerance		projection		product family	
NOTE 3		ISO 1302		ISO 406		ISO 1301		HPC	
ltr	ecn no	dr	date	tolerances unless otherwise specified				title	
T				angles	linear	INCH/MM		4 ROW VERTICAL RECEPTACLE	
				0°±2'		scale 1:1		SOLDER TO BOARD, 0 GUIDE PIN	
		dr	D.SHEAFFER	10/7/92	FCJ		dwg no		sheet 2 of 3
		enr	S.CLARK	10/7/92			50388		A3
		chr	S.CLARK	10/7/92			type		Product Customer Drawing
		appd	S.CLARK	10/7/92					
sheet	revision								
index	sheet								



Copyright FCJ

PRODUCT NUMBER	NUMBER OF POSITIONS SEE NOTE 2	TAIL LENGTH	TAIL PLATING	CONTACT PLATING NOTE 8
50388 -1YYYE	YYY	.125±.010/3.18±0.25	TIN LEAD	30u"/.76u Au
50388 -1YYYF	YYY	.145±.010/3.68±0.25	TIN LEAD	30u"/.76u Au
50388 -1YYYH	YYY	.180±.010/4.57±0.25	TIN LEAD	30u"/.76u Au
50388 -1YYYZ	YYY	.220±.010/5.59±0.25	TIN LEAD	30u"/.76u Au
50388 -3YYYE	YYY	.125±.010/3.18±0.25	TIN LEAD	50u"/1.27u Au
50388 -3YYYF	YYY	.145±.010/3.68±0.25	TIN LEAD	50u"/1.27u Au
50388 -3YYYH	YYY	.180±.010/4.57±0.25	TIN LEAD	50u"/1.27u Au
50388 -3YYYZ	YYY	.220±.010/5.59±0.25	TIN LEAD	50u"/1.27u Au
50388 -5YYYE	YYY	.125±.010/3.18±0.25	TIN LEAD	30u"/.76u GXT
50388 -5YYYELF	YYY	.125±.010/3.18±0.25	TIN	30u"/.76u GXT
50388 -5YYYF	YYY	.145±.010/3.68±0.25	TIN LEAD	30u"/.76u GXT
50388 -5YYYFLF	YYY	.145±.010/3.68±0.25	TIN	30u"/.76u GXT
50388 -5YYYH	YYY	.180±.010/4.57±0.25	TIN LEAD	30u"/.76u GXT
50388 -5YYYHLF	YYY	.180±.010/4.57±0.25	TIN	30u"/.76u GXT
50388 -5YYYZ	YYY	.220±.010/5.59±0.25	TIN LEAD	30u"/.76u GXT
50388 -5YYYZLF	YYY	.220±.010/5.59±0.25	TIN	30u"/.76u GXT



Copyright FCJ

mat'l. code		surface		tolerance		projection		product family		
NOTE 3		ISO 1902		ISO 406		ISO 1901		HPC		
ltr	ecn no	dr	date	tolerances unless otherwise specified				title		
T				angles	linear	.XX±.01/XX±0.3		4 ROW VERTICAL RECEPTACLE		
						.XXX±.006/XX±0.13		SOLDER TO BOARD, 0 GUIDE PIN		
				0'±2'		.XXX±.0020/XXX±0.051		scale 1:1		
		dr	D.SHEAFFER	10/7/92			dwg no		sheet 3 of 3	size
		engr	S.CLARK	10/7/92			50388		A3	
		chr	S.CLARK	10/7/92			type		Product Customer Drawing	
		appd	S.CLARK	10/7/92						
sheet	revision									
index	sheet									

form A3