

REVISIONS			
LTR	DESCRIPTION	DATE (YR-MO-DA)	APPROVED
A	Technical changes in 1.4 and table I. Add figure 3. Change <u>2</u> / of table I and add <u>3</u> / to table I. Add test condition B to burn-in and steady-state life test conditions. Editorial changes throughout	89-02-07	W. Heckman
B	Made technical changes in 1.4 and table I. Added vendor CAGE 27014. Editorial changes throughout.	91-07-11	W. Heckman
C	Update to reflect latest changes in format and requirements. Editorial changes throughout. -les	01-05-21	Raymond Monnin
D	Update drawing to current requirements. Editorial changes throughout. - gap	08-08-14	Robert M. Heber

The original first sheet of this drawing has been replaced.

REV																				
SHEET																				
REV																				
SHEET																				
REV STATUS	REV	D	D	D	D	D	D	D	D	D	D	D								
OF SHEETS	SHEET	1	2	3	4	5	6	7	8	9	10									
PMIC N/A	PREPARED BY Larry T. Gauder	<b>DEFENSE SUPPLY CENTER COLUMBUS</b> <b>COLUMBUS, OHIO 43218-3990</b> <a href="http://www.dsc.dla.mil">http://www.dsc.dla.mil</a>																		
<b>STANDARD MICROCIRCUIT DRAWING</b>  THIS DRAWING IS AVAILABLE FOR USE BY ALL DEPARTMENTS AND AGENCIES OF THE DEPARTMENT OF DEFENSE  AMSC N/A	CHECKED BY Tim H. Noh																			
	APPROVED BY William K. Heckman	MICROCIRCUIT, DIGITAL, BIPOLAR, EDGE TRIGGERED, D-TYPE FLIP-FLOP, MONOLITHIC SILICON																		
	DRAWING APPROVAL DATE 88-04-18																			
	REVISION LEVEL D	SIZE A	CAGE CODE <b>67268</b>	<b>5962-88550</b>																
		SHEET		1 OF 10																

1. SCOPE

1.1 Scope. This drawing describes device requirements for MIL-STD-883 compliant, non-JAN class level B microcircuits in accordance with MIL-PRF-38535, appendix A.

1.2 Part or Identifying Number (PIN). The complete PIN is as shown in the following example:

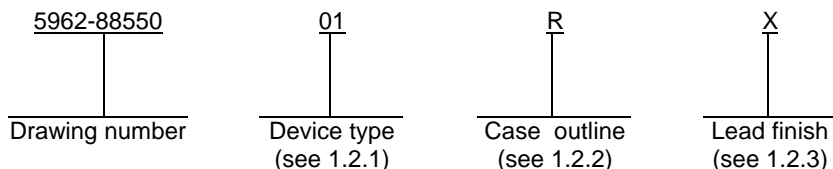

1.2.1 Device type(s). The device type(s) identify the circuit function as follows:

<u>Device type</u>	<u>Generic number</u>	<u>Circuit function</u>
01	54F273	Octal edge triggered, D-type flip-flop with asynchronous master reset

1.2.2 Case outline(s). The case outline(s) are as designated in MIL-STD-1835 and as follows:

<u>Outline letter</u>	<u>Descriptive designator</u>	<u>Terminals</u>	<u>Package style</u>
R	GDIP1-T20 or CDIP2-T20	20	Dual-in-line
S	GDFP2-F20 or CDFP3-F20	20	Flat package
2	CQCC1-N20	20	Square leadless chip carrier

1.2.3 Lead finish. The lead finish is as specified in MIL-PRF-38535, appendix A.

1.3 Absolute maximum ratings.

Supply voltage range .....	-0.5 V dc to +7.0 V dc
Input voltage range ( $V_{IN}$ ) .....	-0.5 V dc to +7.0 V dc
Storage temperature range .....	-65°C to +150°C
Maximum power dissipation ( $P_D$ ) <sup>1/</sup> .....	484 mW
Lead temperature (soldering, 10 seconds) .....	+300°C
Thermal resistance, junction-to-case ( $\theta_{JC}$ ) .....	See MIL-STD-1835
Junction temperature ( $T_J$ ) .....	+175°C

1.4 Recommended operating conditions.

Supply voltage range ( $V_{CC}$ ) .....	+4.5 V dc to +5.5 V dc
Minimum high level input voltage ( $V_{IH}$ ) .....	2.0 V dc
Maximum low level input voltage ( $V_{IL}$ ) .....	0.8 V dc
Case operating temperature range ( $T_C$ ) .....	-55°C to +125°C
Minimum setup time ( $t_s$ ):	
high or low, DATA to CP .....	4.0 ns
Minimum hold time ( $t_h$ ):	
high or low, DATA to CP .....	1.0 ns
Minimum clock pulse width:	
low, CP ( $t_{PW1}$ ) .....	6.0 ns
high or low, MR( $t_{PW2}$ ) .....	6.0 ns
Minimum recovery time ( $t_{REC}$ ):	
MR to CP .....	9.0 ns

<sup>1/</sup> Must withstand the added  $P_D$  due to short circuit test, e.g.,  $I_{OS}$ .

<b>STANDARD MICROCIRCUIT DRAWING</b> DEFENSE SUPPLY CENTER COLUMBUS COLUMBUS, OHIO 43218-3990	SIZE <b>A</b>	REVISION LEVEL <b>D</b>	<b>5962-88550</b>  SHEET <b>2</b>
---	------------------	----------------------------	--

## 2. APPLICABLE DOCUMENTS

2.1 Government specification, standards, and handbooks. The following specification, standards, and handbooks form a part of this drawing to the extent specified herein. Unless otherwise specified, the issues of these documents are those cited in the solicitation or contract.

### DEPARTMENT OF DEFENSE SPECIFICATION

MIL-PRF-38535 - Integrated Circuits, Manufacturing, General Specification for.

### DEPARTMENT OF DEFENSE STANDARDS

MIL-STD-883 - Test Method Standard Microcircuits.  
MIL-STD-1835 - Interface Standard Electronic Component Case Outlines.

### DEPARTMENT OF DEFENSE HANDBOOKS

MIL-HDBK-103 - List of Standard Microcircuit Drawings.  
MIL-HDBK-780 - Standard Microcircuit Drawings.

(Copies of these documents are available online at <http://assist.daps.dla.mil/quicksearch/> or from the Standardization Document Order Desk, 700 Robbins Avenue, Building 4D, Philadelphia, PA 19111-5094.)

2.2 Order of precedence. In the event of a conflict between the text of this drawing and the references cited herein, the text of this drawing takes precedence. Nothing in this document, however, supersedes applicable laws and regulations unless a specific exemption has been obtained.

## 3. REQUIREMENTS

3.1 Item requirements. The individual item requirements shall be in accordance with MIL-PRF-38535, appendix A for non-JAN class level B devices and as specified herein. Product built to this drawing that is produced by a Qualified Manufacturer Listing (QML) certified and qualified manufacturer or a manufacturer who has been granted transitional certification to MIL-PRF-38535 may be processed as QML product in accordance with the manufacturers approved program plan and qualifying activity approval in accordance with MIL-PRF-38535. This QML flow as documented in the Quality Management (QM) plan may make modifications to the requirements herein. These modifications shall not affect form, fit, or function of the device. These modifications shall not affect the PIN as described herein. A "Q" or "QML" certification mark in accordance with MIL-PRF-38535 is required to identify when the QML flow option is used.

3.2 Design, construction, and physical dimensions. The design, construction, and physical dimensions shall be as specified in MIL-PRF-38535, appendix A and herein.

3.2.1 Case outlines. The case outlines shall be in accordance with 1.2.2 herein.

3.2.2 Terminal connections. The terminal connections shall be as specified on figure 1.

3.2.3 Truth table. The truth table shall be as specified on figure 2.

3.2.4 Test circuit and switching waveforms. The test circuit and switching waveforms shall be as specified on figure 3.

3.3 Electrical performance characteristics. Unless otherwise specified herein, the electrical performance characteristics are as specified in table I and shall apply over the full case operating temperature range.

3.4 Electrical test requirements. The electrical test requirements shall be the subgroups specified in table II. The electrical tests for each subgroup are described in table I.

<b>STANDARD MICROCIRCUIT DRAWING</b> DEFENSE SUPPLY CENTER COLUMBUS COLUMBUS, OHIO 43218-3990	SIZE <b>A</b>		<b>5962-88550</b>
		REVISION LEVEL <b>D</b>	SHEET <b>3</b>

3.5 Marking. Marking shall be in accordance with MIL-PRF-38535, appendix A. The part shall be marked with the PIN listed in 1.2 herein. In addition, the manufacturer's PIN may also be marked. For packages where marking of the entire SMD PIN number is not feasible due to space limitations, the manufacturer has the option of not marking the "5962-" on the device.

3.5.1 Certification/compliance mark. A compliance indicator "C" shall be marked on all non-JAN devices built in compliance to MIL-PRF-38535, appendix A. The compliance indicator "C" shall be replaced with a "Q" or "QML" certification mark in accordance with MIL-PRF-38535 to identify when the QML flow option is used.

3.6 Certificate of compliance. A certificate of compliance shall be required from a manufacturer in order to be listed as an approved source of supply in MIL-HDBK-103 (see 6.6 herein). The certificate of compliance submitted to DSCC-VA prior to listing as an approved source of supply shall affirm that the manufacturer's product meets the requirements of MIL-PRF-38535, appendix A and the requirements herein.

3.7 Certificate of conformance. A certificate of conformance as required in MIL-PRF-38535, appendix A shall be provided with each lot of microcircuits delivered to this drawing.

3.8 Notification of change. Notification of change to DSCC-VA shall be required for any change that affects this drawing.

3.9 Verification and review. DSCC, DSCC's agent, and the acquiring activity retain the option to review the manufacturer's facility and applicable required documentation. Offshore documentation shall be made available onshore at the option of the reviewer.

4. VERIFICATION

4.1 Sampling and inspection. Sampling and inspection procedures shall be in accordance with MIL-PRF-38535, appendix A.

4.2 Screening. Screening shall be in accordance with method 5004 of MIL-STD-883, and shall be conducted on all devices prior to quality conformance inspection. The following additional criteria shall apply:

- a. Burn-in test, method 1015 of MIL-STD-883.
  - (1) Test condition A, B, or D. The test circuit shall be maintained by the manufacturer under document revision level control and shall be made available to the preparing or acquiring activity upon request. The test circuit shall specify the inputs, outputs, biases, and power dissipation, as applicable, in accordance with the intent specified in method 1015 of MIL-STD-883.
  - (2)  $T_A = +125^{\circ}\text{C}$ , minimum.
- b. Interim and final electrical test parameters shall be as specified in table II herein, except interim electrical parameter tests prior to burn-in are optional at the discretion of the manufacturer.

<b>STANDARD MICROCIRCUIT DRAWING</b> DEFENSE SUPPLY CENTER COLUMBUS COLUMBUS, OHIO 43218-3990	SIZE <b>A</b>		<b>5962-88550</b>
		REVISION LEVEL <b>D</b>	SHEET <b>4</b>

TABLE I. Electrical performance characteristics.

Test	Symbol	Conditions -55°C ≤ T <sub>C</sub> ≤ +125°C unless otherwise specified	Group A subgroups	Limits		Unit
				Min	Max	
High level output voltage	V <sub>OH</sub>	V <sub>CC</sub> = 4.5 V, V <sub>IL</sub> = 0.8 V, V <sub>IH</sub> = 2.0 V, I <sub>OH</sub> = -1.0 mA	1, 2, 3	2.5		V
Low level output voltage	V <sub>OL</sub>	V <sub>CC</sub> = 4.5 V, V <sub>IL</sub> = 0.8 V, V <sub>IH</sub> = 2.0 V, I <sub>OL</sub> = 20 mA	1, 2, 3		0.5	V
Input clamp voltage	V <sub>IC</sub>	V <sub>CC</sub> = 4.5 V, I <sub>N</sub> = -18 mA	1, 2, 3		-1.2	V
Low level input current	I <sub>IL</sub>	V <sub>CC</sub> = 5.5 V, V <sub>IN</sub> = 0.5 V, Inputs not under test > 4.5 V	1, 2, 3		-0.6	mA
High level input current	I <sub>IH</sub>	V <sub>CC</sub> = 5.5 V, V <sub>IN</sub> = 2.7 V, Inputs not under test > 4.5 V	1, 2, 3		20	μA
Short circuit output current	I <sub>OS</sub>	V <sub>CC</sub> = 5.5 V, V <sub>OUT</sub> = 0.0 V <u>1/</u>	1, 2, 3	-60	-150	mA
Power supply current	I <sub>CCH</sub>	V <sub>CC</sub> = 5.5 V, V <sub>IN</sub> = 4.5 V	1, 2, 3		85	mA
	I <sub>CCL</sub>	V <sub>CC</sub> = 5.5 V, V <sub>IN</sub> = 0.0 V	1, 2, 3		88	mA
Functional tests		See 4.3.1c	7, 8			
Propagation delay time, CP to Qn	t <sub>PLH1</sub>	V <sub>CC</sub> = 5.5 V, C <sub>L</sub> = 50 pF	9, 10, 11	2.5	11.5	ns
	t <sub>PHL1</sub>	R <sub>L</sub> = 500 Ω <u>2/</u>		3.0	12.0	ns
Propagation delay time, MR to Qn	t <sub>PHL2</sub>	See figure 3		3.0	12.0	ns
Maximum clock frequency <u>3/</u>	f <sub>MAX</sub>		9	100		MHz

1/ Not more than one output should be shorted at a time, and the duration of the short circuit condition should not exceed one second.

2/ Propagation delay limits are based on single output switching. Unused outputs = 3.5 V or ≤ 0.3 V.

3/ f<sub>MAX</sub>, is guaranteed, but not tested, at V<sub>CC</sub> = 5.5 V, T<sub>C</sub> = -55°C and T<sub>C</sub> = +125°C.

**STANDARD  
MICROCIRCUIT DRAWING**  
DEFENSE SUPPLY CENTER COLUMBUS  
COLUMBUS, OHIO 43218-3990

SIZE  
**A**

**5962-88550**

REVISION LEVEL  
**D**

SHEET  
**5**

Device types	01
Case outlines	R, S, and 2
Terminal number	Terminal Symbol
1	$\overline{MR}$
2	Q0
3	D0
4	D1
5	Q1
6	Q2
7	D2
8	D3
9	Q3
10	GND
11	CP
12	Q4
13	D4
14	D5
15	Q5
16	Q6
17	D6
18	D7
19	Q7
20	V <sub>CC</sub>

Connection	Description
Q0 - Q7	Data outputs
D0 - D7	Data inputs
CP	Clock pulse input (Active rising edge)
$\overline{MR}$	Master reset (active low)

FIGURE 1. Terminal connections.

Operating mode	Inputs			Outputs
	$\overline{MR}$	CP	D <sub>n</sub>	Q <sub>n</sub>
Reset (clear)	L	X	X	L
Load (1)	H	↑	h	H
Load (0)	H	↑	l	L

H = High voltage level steady state.  
h = High voltage level one setup time prior to the low-to-high clock transition.  
L = Low voltage level steady state.  
l = Low voltage level one setup time prior to the low-to-high clock transition.  
X = Irrelevant.  
↑ = Low-to-high clock transition.

FIGURE 2. Truth table.

<b>STANDARD MICROCIRCUIT DRAWING</b> DEFENSE SUPPLY CENTER COLUMBUS COLUMBUS, OHIO 43218-3990	SIZE <b>A</b>		<b>5962-88550</b>
		REVISION LEVEL <b>D</b>	SHEET <b>6</b>

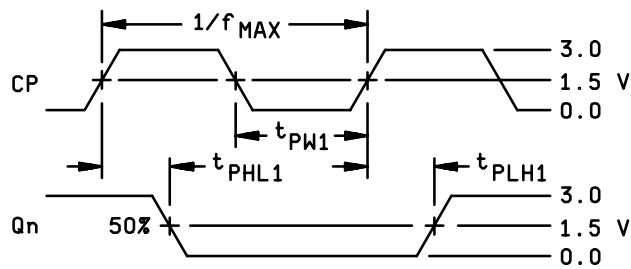
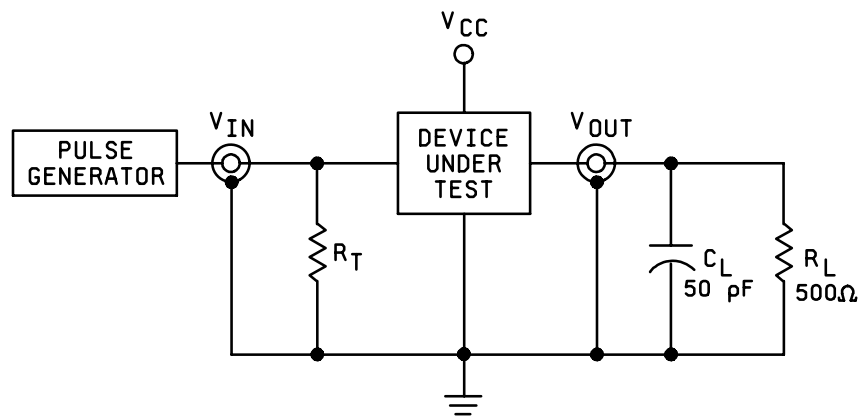

PROPAGATION DELAY TIMES  
CLOCK AND OUTPUT

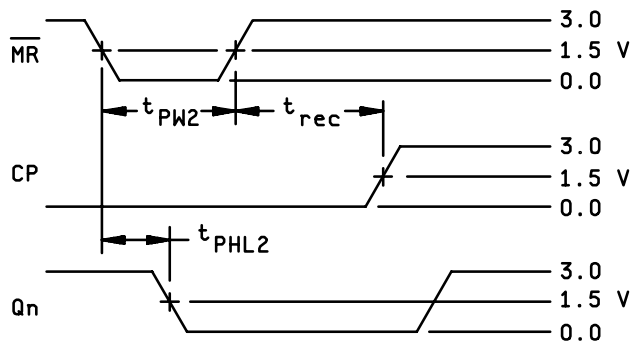

PROPAGATION DELAY TIMES  
MASTER RESET TO CLOCK AND OUTPUT

FIGURE 3. Test circuit and switching waveforms.

**STANDARD  
MICROCIRCUIT DRAWING**  
DEFENSE SUPPLY CENTER COLUMBUS  
COLUMBUS, OHIO 43218-3990

SIZE  
**A**

**5962-88550**

REVISION LEVEL  
**D**

SHEET  
**7**

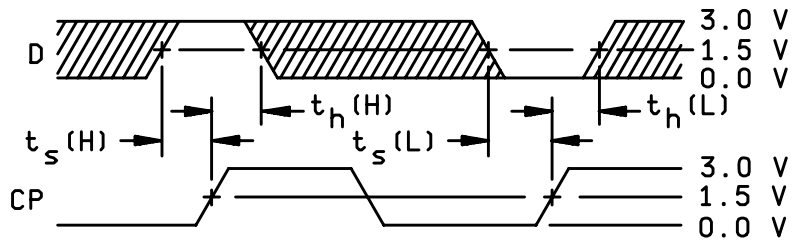

DATA SETUP AND HOLD TIMES

NOTES:

1.  $C_L$  includes probe and jig capacitance.
2. Input pulse characteristics: PRR = 1MHz,  $t_{TLH} = t_{THL} = 2.5$  ns, duty cycle = 50%.
3.  $R_T \approx Z_{OUT}$  of pulse generators.
4. The shaded areas indicate when the input is permitted to change for predictable output performance.

FIGURE 3. Test circuit and switching waveforms - Continued.

<b>STANDARD MICROCIRCUIT DRAWING</b> DEFENSE SUPPLY CENTER COLUMBUS COLUMBUS, OHIO 43218-3990	SIZE <b>A</b>		<b>5962-88550</b>
		REVISION LEVEL <b>D</b>	SHEET <b>8</b>



TABLE II. Electrical test requirements.

MIL-STD-883 test requirements	Subgroups (in accordance with MIL-STD-883, method 5005, table I)
Interim electrical parameters (method 5004)	- - -
Final electrical test parameters (method 5004)	1*, 2, 3, 7, 8, 9, 10, 11
Group A test requirements (method 5005)	1, 2, 3, 7, 8, 9, 10, 11
Groups C and D end-point electrical parameters (method 5005)	1, 2, 3

\* PDA applies to subgroup 1.

4.3 Quality conformance inspection. Quality conformance inspection shall be in accordance with method 5005 of MIL-STD-883 including groups A, B, C, and D inspections. The following additional criteria shall apply.

4.3.1 Group A inspection.

- a. Tests shall be as specified in table II herein.
- b. Subgroups 4, 5, and 6 in table I, method 5005 of MIL-STD-883 shall be omitted.
- c. Subgroups 7 and 8 shall include verification of the truth table.

4.3.2 Groups C and D inspections.

- a. End-point electrical parameters shall be as specified in table II herein.
- b. Steady-state life test conditions, method 1005 of MIL-STD-883.
  - (1) Test condition A, B, or D. The test circuit shall be maintained by the manufacturer under document revision level control and shall be made available to the preparing or acquiring activity upon request. The test circuit shall specify the inputs, outputs, biases, and power dissipation, as applicable, in accordance with the intent specified in method 1005 of MIL-STD-883.
  - (2)  $T_A = +125^{\circ}\text{C}$ , minimum.
  - (3) Test duration: 1,000 hours, except as permitted by method 1005 of MIL-STD-883.

<b>STANDARD MICROCIRCUIT DRAWING</b> DEFENSE SUPPLY CENTER COLUMBUS COLUMBUS, OHIO 43218-3990	SIZE <b>A</b>		<b>5962-88550</b>
		REVISION LEVEL <b>D</b>	SHEET <b>9</b>

5. PACKAGING

5.1 Packaging requirements. The requirements for packaging shall be in accordance with MIL-PRF-38535, appendix A.

6. NOTES

6.1 Intended use. Microcircuits conforming to this drawing are intended for use for Government microcircuit applications (original equipment), design applications, and logistics purposes.

6.2 Replaceability. Microcircuits covered by this drawing will replace the same generic device covered by a contractor-prepared specification or drawing.

6.3 Configuration control of SMD's. All proposed changes to existing SMD's will be coordinated with the users of record for the individual documents. This coordination will be accomplished using DD Form 1692, Engineering Change Proposal.

6.4 Record of users. Military and industrial users shall inform Defense Supply Center Columbus (DSCC) when a system application requires configuration control and the applicable SMD. DSCC will maintain a record of users and this list will be used for coordination and distribution of changes to the drawings. Users of drawings covering microelectronics devices (FSC 5962) should contact DSCC-VA, telephone (614) 692-0544.

6.5 Comments. Comments on this drawing should be directed to DSCC-VA, Columbus, Ohio 43218-3990, or telephone (614) 692-0547.

6.6 Approved sources of supply. Approved sources of supply are listed in MIL-HDBK-103. The vendors listed in MIL-HDBK-103 have agreed to this drawing and a certificate of compliance (see 3.6 herein) has been submitted to and accepted by DSCC-VA.

<b>STANDARD MICROCIRCUIT DRAWING</b> DEFENSE SUPPLY CENTER COLUMBUS COLUMBUS, OHIO 43218-3990	SIZE <b>A</b>		<b>5962-88550</b>
		REVISION LEVEL <b>D</b>	SHEET <b>10</b>

STANDARD MICROCIRCUIT DRAWING BULLETIN

DATE: 08-08-14

Approved sources of supply for SMD 5962-88550 are listed below for immediate acquisition information only and shall be added to MIL-HDBK-103 and QML-38535 during the next revision. MIL-HDBK-103 and QML-38535 will be revised to include the addition or deletion of sources. The vendors listed below have agreed to this drawing and a certificate of compliance has been submitted to and accepted by DSCC-VA. This information bulletin is superseded by the next dated revision of MIL-HDBK-103 and QML-38535. DSCC maintains an online database of all current sources of supply at <http://www.dscclia.mil/Programs/Smcr/>.

Standard microcircuit drawing PIN <u>1/</u>	Vendor CAGE number	Vendor similar PIN <u>2/</u>
5962-8855001RA	0C7V7	54F273DMQB
	<u>3/</u>	54F273/BRA
5962-8855001SA	0C7V7	54F273FMQB
	<u>3/</u>	54273/BSA
5962-88550012A	0C7V7	54F273LMQB
	<u>3/</u>	54F273/B2A

- 1/ The lead finish shown for each PIN representing a hermetic package is the most readily available from the manufacturer listed for that part. If the desired lead finish is not listed contact the vendor to determine its availability.
- 2/ Caution. Do not use this number for item acquisition. Items acquired to this number may not satisfy the performance requirements of this drawing.
- 3/ Not available from an approved source of supply.

Vendor CAGE  
number

0C7V7

Vendor name  
and address

QP Semiconductor  
2945 Oakmead Village Court  
Santa Clara, CA 95051

The information contained herein is disseminated for convenience only and the Government assumes no liability whatsoever for any inaccuracies in the information bulletin.