

REVISIONS			
LTR	DESCRIPTION	DATE (YR-MO-DA)	APPROVED
A	Make changes to 1.5 and glassivation as specified under APPENDIX A. - ro	99-04-13	R. MONNIN
B	Add device type 02. Make changes to 1.2.2, 1.4, table I, figures 1, 2, 3 and APPENDIX A. - ro	99-06-02	R. MONNIN

REV																				
SHEET																				
REV	B	B	B	B																
SHEET	15	16	17	18																
REV STATUS OF SHEETS	REV			B	B	B	B	B	B	B	B	B	B	B	B	B	B	B	B	B
	SHEET			1	2	3	4	5	6	7	8	9	10	11	12	13	14			
PMIC N/A	PREPARED BY RICK OFFICER				<b>DEFENSE SUPPLY CENTER COLUMBUS COLUMBUS, OHIO 43216</b>															
<b>STANDARD MICROCIRCUIT DRAWING</b>  THIS DRAWING IS AVAILABLE FOR USE BY ALL DEPARTMENTS AND AGENCIES OF THE DEPARTMENT OF DEFENSE  AMSC N/A	CHECKED BY RAJESH PITHADIA																			
	APPROVED BY RAYMOND MONNIN																			
	DRAWING APPROVAL DATE 99-04-01																			
	REVISION LEVEL B																			
				SIZE A	CAGE CODE 67268	<b>5962-99511</b>														
				SHEET 1 OF 18																

1. SCOPE

1.1 Scope. This drawing documents three product assurance class levels consisting of high reliability (device classes Q and M), space application (device class V) and for appropriate satellite and similar applications (device class T). A choice of case outlines and lead finishes are available and are reflected in the Part or Identifying Number (PIN). When available, a choice of Radiation Hardness Assurance (RHA) levels are reflected in the PIN. For device class T, the user is encouraged to review the manufacturer's Quality Management (QM) plan as part of their evaluation of these parts and their acceptability in the intended application.

1.2 PIN. The PIN is as shown in the following example:

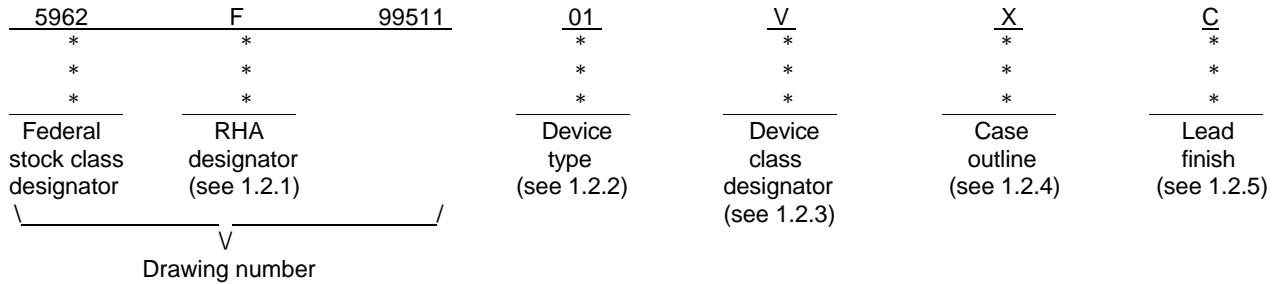

1.2.1 RHA designator. Device classes Q, T, and V RHA marked devices meet the MIL-PRF-38535 specified RHA levels and are marked with the appropriate RHA designator. Device class M RHA marked devices meet the MIL-PRF-38535, appendix A specified RHA levels and are marked with the appropriate RHA designator. A dash (-) indicates a non-RHA device.

1.2.2 Device type(s). The device type(s) identify the circuit function as follows:

<u>Device type</u>	<u>Generic number</u>	<u>Circuit function</u>
01	HS-4423RH	Radiation hardened dual inverting MOSFET drivers with <10 V lockout voltage
02	HS-4423BRH	Radiation hardened dual inverting MOSFET drivers with < 7.5 V lockout voltage

1.2.3 Device class designator. The device class designator is a single letter identifying the product assurance level as follows:

<u>Device class</u>	<u>Device requirements documentation</u>
M	Vendor self-certification to the requirements for MIL-STD-883 compliant, non-JAN class level B microcircuits in accordance with MIL-PRF-38535, appendix A
Q, V	Certification and qualification to MIL-PRF-38535
T	Certification and qualification to MIL-PRF-38535 with performance as specified in the device manufacturers approved quality management plan.

1.2.4 Case outline(s). The case outline(s) are as designated in MIL-STD-1835 and as follows:

<u>Outline letter</u>	<u>Descriptive designator</u>	<u>Terminals</u>	<u>Package style</u>
X	CDFP4-F16	16	Flat pack

1.2.5 Lead finish. The lead finish is as specified in MIL-PRF-38535 for device classes Q, T, and V or MIL-PRF-38535, appendix A for device class M.

<b>STANDARD MICROCIRCUIT DRAWING</b> DEFENSE SUPPLY CENTER COLUMBUS COLUMBUS, OHIO 43216-5000	SIZE <b>A</b>	REVISION LEVEL <b>B</b>	<b>5962-99511</b>  SHEET <b>2</b>
---	------------------	----------------------------	--

1.3 Absolute maximum ratings. 1/

Supply voltage range (V <sub>S</sub> ).....	10 V to 20 V
Input voltage range (V <sub>IN</sub> ).....	-0.3 V to +V 2/
Output short circuit duration (single supply) .....	Continuous 3/
Maximum junction temperature (T <sub>J</sub> ) .....	175°C
Maximum storage temperature .....	-65°C to +150°C
Maximum lead temperature (soldering 10 seconds) .....	265°C
Thermal resistance, junction-to-case (θ <sub>JC</sub> ).....	18°C/W
Thermal resistance, junction-to-ambient (θ <sub>JA</sub> ).....	90°C/W 4/

1.4 Recommended operating conditions.

Supply voltage range (V <sub>S</sub> ).....	12 V to 18 V
Low voltage lockout voltage:	
Device type 01 .....	< 10.0 V
Device type 02 .....	< 7.5 V
Operating temperature range.....	-55°C to +125°C

1.5 Radiation features.

SEP effective let no upsets .....	TBD
Maximum total dose available: (dose rate = 50 - 300 rad(Si) / s)	
Device classes M, Q, and V.....	300 Krads (Si)
Device class T.....	100 Krads (Si)
Latch up immune.....	5/

2. APPLICABLE DOCUMENTS

2.1 Government specification, standards, and handbooks. The following specification, standards, and handbooks form a part of this drawing to the extent specified herein. Unless otherwise specified, the issues of these documents are those listed in the issue of the Department of Defense Index of Specifications and Standards (DoDISS) and supplement thereto, cited in the solicitation.

SPECIFICATION

DEPARTMENT OF DEFENSE

MIL-PRF-38535 - Integrated Circuits, Manufacturing, General Specification for.

STANDARDS

DEPARTMENT OF DEFENSE

- MIL-STD-883 - Test Method Standard Microcircuits.
- MIL-STD-973 - Configuration Management.
- MIL-STD-1835 - Interface Standard For Microcircuit Case Outlines.

1/ Stresses above the absolute maximum rating may cause permanent damage to the device. Extended operation at the maximum levels may degrade performance and affect reliability.  
 2/ Inputs must not go more negative than -0.3V.  
 3/ Short circuit from the output to V<sub>S</sub> can cause excessive heating and eventual destruction.  
 4/ θ<sub>JA</sub> is measured with the component mounted on an evaluation PC board in free air.  
 5/ Guaranteed by process or design.

<b>STANDARD MICROCIRCUIT DRAWING</b> DEFENSE SUPPLY CENTER COLUMBUS COLUMBUS, OHIO 43216-5000	SIZE <b>A</b>		<b>5962-99511</b>
		REVISION LEVEL <b>B</b>	SHEET <b>3</b>

HANDBOOKS

DEPARTMENT OF DEFENSE

- MIL-HDBK-103 - List of Standard Microcircuit Drawings (SMD's).
- MIL-HDBK-780 - Standard Microcircuit Drawings.

(Unless otherwise indicated, copies of the specification, standards, and handbooks are available from the Standardization Document Order Desk, 700 Robbins Avenue, Building 4D, Philadelphia, PA 19111-5094.)

2.2 Order of precedence. In the event of a conflict between the text of this drawing and the references cited herein, the text of this drawing takes precedence. Nothing in this document, however, supersedes applicable laws and regulations unless a specific exemption has been obtained.

3. REQUIREMENTS

3.1 Item requirements. The individual item requirements for device classes Q, T, and V shall be in accordance with MIL-PRF-38535 and as specified herein or as modified in the device manufacturer's Quality Management (QM) plan. The modification in the QM plan shall not affect the form, fit, or function as described herein. The individual item requirements for device class M shall be in accordance with MIL-PRF-38535, appendix A and as specified herein.

3.1.1 Microcircuit die. For the requirements for microcircuit die, see appendix A to this document.

3.2 Design, construction, and physical dimensions. The design, construction, and physical dimensions shall be as specified in MIL-PRF-38535 and herein for device classes Q, T, and V or MIL-PRF-38535, appendix A and herein for device class M.

3.2.1 Case outline(s). The case outline(s) shall be in accordance with 1.2.4 herein.

3.2.2 Terminal connection(s). The terminal connection(s) shall be as specified on figure 1.

3.2.3 Logic diagram(s). The logic diagram(s) shall be as specified on figure 2.

3.2.4 Truth table. The truth table shall be as specified in figure 3.

3.2.5 Radiation exposure circuit. The radiation exposure circuit shall be as specified on figure 4.

3.3 Electrical performance characteristics and postirradiation parameter limits. Unless otherwise specified herein, the electrical performance characteristics and postirradiation parameter limits are as specified in table I and shall apply over the full case operating temperature range.

3.4 Electrical test requirements. The electrical test requirements shall be the subgroups specified in table IIA. The electrical tests for each subgroup are defined in table I.

3.5 Marking. The part shall be marked with the PIN listed in 1.2 herein. In addition, the manufacturer's PIN may also be marked as listed in MIL-HDBK-103. For packages where marking of the entire SMD PIN number is not feasible due to space limitations, the manufacturer has the option of not marking the "5962-" on the device. For RHA product using this option, the RHA designator shall still be marked. Marking for device classes Q, T, and V shall be in accordance with MIL-PRF-38535. Marking for device class M shall be in accordance with MIL-PRF-38535, appendix A.

3.5.1 Certification/compliance mark. The certification mark for device classes Q, T, and V shall be a "QML" or "Q" as required in MIL-PRF-38535. The compliance mark for device class M shall be a "C" as required in MIL-PRF-38535, appendix A.

3.6 Certificate of compliance. For device classes Q, T, and V, a certificate of compliance shall be required from a QML-38535 listed manufacturer in order to supply to the requirements of this drawing (see 6.6.1 herein). For device class M, a certificate of compliance shall be required from a manufacturer in order to be listed as an approved source of supply in MIL-HDBK-103 (see 6.6.2 herein). The certificate of compliance submitted to DSCC-VA prior to listing as an approved source of supply for this drawing shall affirm that the manufacturer's product meets, for device classes Q, T, and V, the requirements of MIL-PRF-38535 and herein or for device class M, the requirements of MIL-PRF-38535, appendix A and herein.

<b>STANDARD MICROCIRCUIT DRAWING</b> DEFENSE SUPPLY CENTER COLUMBUS COLUMBUS, OHIO 43216-5000	SIZE <b>A</b>		<b>5962-99511</b>
		REVISION LEVEL <b>B</b>	SHEET <b>4</b>

TABLE I. Electrical performance characteristics.

Test	Symbol	Conditions <u>1/</u> -55°C ≤ T <sub>C</sub> ≤ +125°C unless otherwise specified	Group A subgroups	Device type	Limits		Unit
					Min	Max	
Power supply current, low	I <sub>CCSB</sub> low	V <sub>S</sub> = 18 V, inputs = 0 V  M,D,P,L,R,F <u>2/</u>	1	01,02		3.5	mA
			2,3			4.0	
			1			4.0	
Power supply current, high	I <sub>CCSB</sub> high	V <sub>S</sub> = 18 V, inputs = 18 V  M,D,P,L,R,F <u>2/</u>	1	01,02		3.5	mA
			2,3			4.0	
			1			4.0	
Input current, low	I <sub>IL</sub>	V <sub>S</sub> = 18 V  M,D,P,L,R,F <u>2/</u>	1	01,02		±2	μA
			2,3			±4	
			1			±4	
Input current, high	I <sub>IH</sub>	V <sub>S</sub> = 18 V  M,D,P,L,R,F <u>2/</u>	1	01,02		±2	μA
			2,3			±4	
			1			±4	
Voltage output	V <sub>OL</sub> ,  V <sub>OH</sub>	V <sub>S</sub> = 12 V  M,D,P,L,R,F <u>2/</u>	1	01,02	V <sub>S</sub> - 0.75	0.8	V
			2,3		V <sub>S</sub> - 0.75	0.8	
			1		V <sub>S</sub> - 0.75	0.8	
Input voltage	V <sub>IL</sub> , V <sub>IH</sub>	V <sub>S</sub> = 12 V, limits applied during functional test  M,D,P,L,R,F <u>2/</u>	1	01,02	3.0	0.4	V
			2,3		3.5	0.4	
			1		3.5	0.4	
Functional test	F <sub>T</sub>	V <sub>S</sub> = 12 V,  V <sub>S</sub> = 18 V  M,D,P,L,R,F <u>2/</u>	7,8A,8B	01,02			
			7				

See footnotes at end of table.

<b>STANDARD MICROCIRCUIT DRAWING</b> DEFENSE SUPPLY CENTER COLUMBUS COLUMBUS, OHIO 43216-5000	SIZE <b>A</b>		<b>5962-99511</b>
		REVISION LEVEL <b>B</b>	SHEET <b>5</b>

TABLE I. Electrical performance characteristics – Continued.

Test	Symbol	Conditions <u>1/</u> -55°C ≤ T <sub>C</sub> ≤ +125°C unless otherwise specified	Group A subgroups	Device type	Limits		Unit
					Min	Max	
Propagation delay, low	t <sub>PHL</sub>	V <sub>S</sub> = 12 V, C <sub>L</sub> = 4300 pF M,D,P,L,R,F <u>2/</u>	9	01,02		250	ns
			10,11			350	
			9			350	
Propagation delay, high	t <sub>PLH</sub>	V <sub>S</sub> = 12 V C <sub>L</sub> = 4300 pF M,D,P,L,R,F <u>2/</u>	9	01,02		250	ns
			10,11			350	
			9			350	
Response time, rise	TR	V <sub>S</sub> = 12 V, C <sub>L</sub> = 4300 pF M,D,P,L,R,F <u>2/</u>	9	01,02		75	ns
			10,11			95	
			9			95	
Response time, fall	TF	V <sub>S</sub> = 12 V, C <sub>L</sub> = 4300 pF M,D,P,L,R,F <u>2/</u>	9	01,02		75	ns
			10,11			95	
			9			95	

1/ V<sub>S</sub> = 12 V to 18 V.

2/ The devices supplied to this drawing meet all levels M, D, P, L, R, F of irradiation (classes M, Q, and V), and all levels M, D, P, L, R for class T. However, this device is only tested at the "F" level (classes M, Q, and V) and for class T, "R" level (see paragraph 1.5). Pre and Post irradiation values are identical unless otherwise specified in Table I.

When performing post irradiation electrical measurements for any RHA level, T<sub>A</sub> = +25°C.

3.7 Certificate of conformance. A certificate of conformance as required for device classes Q, T, and V in MIL-PRF-38535 or for device class M in MIL-PRF-38535, appendix A shall be provided with each lot of microcircuits delivered to this drawing.

3.8 Notification of change for device class M. For device class M, notification to DSCC-VA of change of product (see 6.2 herein) involving devices acquired to this drawing is required for any change as defined in MIL-STD-973.

3.9 Verification and review for device class M. For device class M, DSCC, DSCC's agent, and the acquiring activity retain the option to review the manufacturer's facility and applicable required documentation. Offshore documentation shall be made available onshore at the option of the reviewer.

3.10 Microcircuit group assignment for device class M. Device class M devices covered by this drawing shall be in microcircuit group number 89 (see MIL-PRF-38535, appendix A).

<b>STANDARD MICROCIRCUIT DRAWING</b> DEFENSE SUPPLY CENTER COLUMBUS COLUMBUS, OHIO 43216-5000	SIZE <b>A</b>		<b>5962-99511</b>
		REVISION LEVEL <b>B</b>	SHEET <b>6</b>

Device types	01 and 02
Case outline	X
Terminal number	Terminal symbol
1	NC
2	INPUT A
3	NC
4	GND
5	GND
6	NC
7	INPUT B
8	NC
9	NC
10	$\overline{\text{OUTPUT B}}$
11	$\overline{\text{OUTPUT B}}$
12	$V_S$
13	$V_S$
14	$\overline{\text{OUTPUT A}}$
15	$\overline{\text{OUTPUT A}}$
16	NC

FIGURE 1. Terminal connections.

<b>STANDARD MICROCIRCUIT DRAWING</b> DEFENSE SUPPLY CENTER COLUMBUS COLUMBUS, OHIO 43216-5000	SIZE <b>A</b>		<b>5962-99511</b>
		REVISION LEVEL <b>B</b>	SHEET <b>7</b>

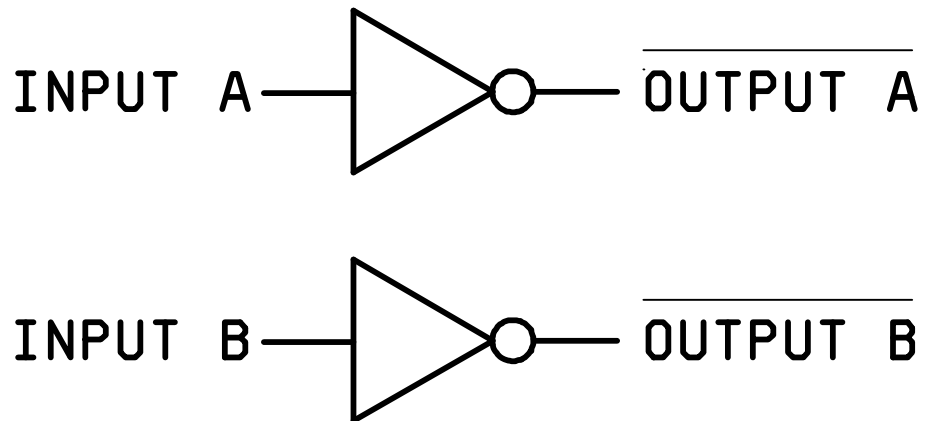

FIGURE 2. Logic diagram.

INPUT A	$\overline{\text{OUTPUT A}}$
1	0
0	1
INPUT B	$\overline{\text{OUTPUT B}}$
1	0
0	1

FIGURE 3. Truth table.

<b>STANDARD MICROCIRCUIT DRAWING</b> DEFENSE SUPPLY CENTER COLUMBUS COLUMBUS, OHIO 43216-5000	SIZE <b>A</b>		5962-99511
		REVISION LEVEL <b>B</b>	SHEET <b>8</b>



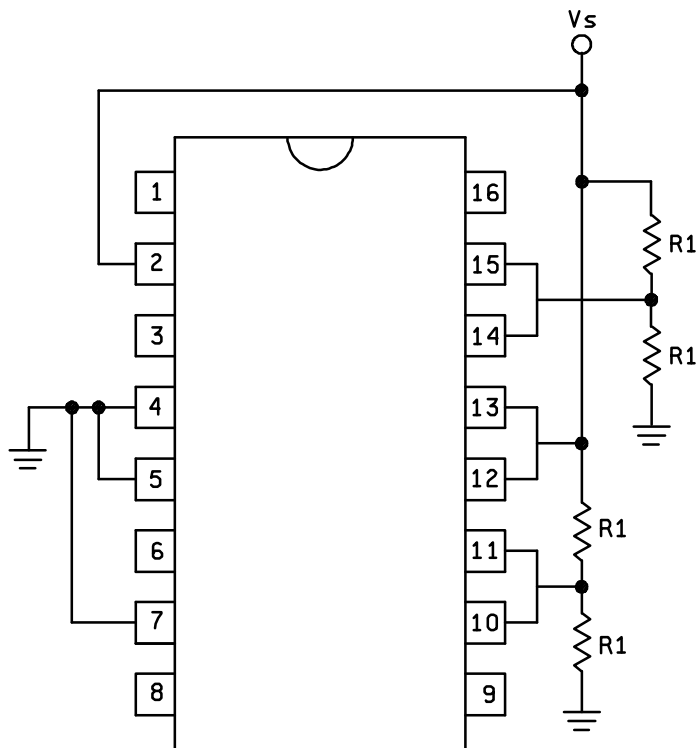

NOTES:  $V_S = 15\text{ V}$  and  $R1 = 5\text{ k}\Omega$ .

FIGURE 4. Radiation exposure circuit.

<b>STANDARD MICROCIRCUIT DRAWING</b> DEFENSE SUPPLY CENTER COLUMBUS COLUMBUS, OHIO 43216-5000	SIZE <b>A</b>		<b>5962-99511</b>
		REVISION LEVEL <b>B</b>	SHEET <b>9</b>

4. QUALITY ASSURANCE PROVISIONS

4.1 Sampling and inspection. For device classes Q, and V, sampling and inspection procedures shall be in accordance with MIL-PRF-38535 or as modified in the device manufacturer's Quality Management (QM) plan, including screening (4.2), qualification (4.3), and conformance inspection (4.4). The modification in the QM plan shall not affect the form, fit, or function as described herein.

For device class T, sampling and inspection procedures shall be in accordance with MIL-PRF-38535 and the device manufacturer's QM plan, including screening, qualification, and conformance inspection. The performance envelope and reliability information shall be as specified in the manufacturer's QM plan.

For device class M, sampling and inspection procedures shall be in accordance with MIL-PRF-38535, appendix A.

4.2 Screening. For device classes Q and V, screening shall be in accordance with MIL-PRF-38535, and shall be conducted on all devices prior to qualification and technology conformance inspection. For device class M, screening shall be in accordance with method 5004 of MIL-STD-883, and shall be conducted on all devices prior to quality conformance inspection. For device class T, screening shall be in accordance with the device manufacturer's Quality Management (QM) plan, and shall be conducted on all devices prior to qualification and technology conformance inspection.

4.2.1 Additional criteria for device class M.

- a. Burn-in test, method 1015 of MIL-STD-883.
  - (1) Test condition A, B, C, or D. The test circuit shall be maintained by the manufacturer under document revision level control and shall be made available to the preparing or acquiring activity upon request. The test circuit shall specify the inputs, outputs, biases, and power dissipation, as applicable, in accordance with the intent specified in test method 1015.
  - (2)  $T_A = +125^{\circ}\text{C}$ , minimum.
- b. Interim and final electrical test parameters shall be as specified in table IIA herein.

4.2.2 Additional criteria for device classes Q, T, and V.

- a. The burn-in test duration, test condition and test temperature, or approved alternatives shall be as specified in the device manufacturer's QM plan in accordance with MIL-PRF-38535. The burn-in test circuit shall be maintained under document revision level control of the device manufacturer's Technology Review Board (TRB) in accordance with MIL-PRF-38535 and shall be made available to the acquiring or preparing activity upon request. The test circuit shall specify the inputs, outputs, biases, and power dissipation, as applicable, in accordance with the intent specified in test method 1015 of MIL-STD-883.
- b. Interim and final electrical test parameters shall be as specified in table IIA herein.
- c. Additional screening for device class V beyond the requirements of device class Q shall be as specified in MIL-PRF-38535, appendix B or as modified in the device manufacturer's quality management (QM) plan.

4.3 Qualification inspection for device classes Q, T and V. Qualification inspection for device classes Q and V shall be in accordance with MIL-PRF-38535. Qualification inspection for device class T shall be in accordance with the device manufacturer's Quality Management (QM) plan. Inspections to be performed shall be those specified in MIL-PRF-38535 and herein for groups A, B, C, D, and E inspections (see 4.4.1 through 4.4.4).

4.4 Conformance inspection. Technology conformance inspection for classes Q and V shall be in accordance with MIL-PRF-38535 including groups A, B, C, D, and E inspections and as specified herein except where option 2 of MIL-PRF-38535 permits alternate in-line control testing. Quality conformance inspection for device class M shall be in accordance with MIL-PRF-38535, appendix A and as specified herein. Inspections to be performed for device class M shall be those specified in method 5005 of MIL-STD-883 and herein for groups A, B, C, D, and E inspections (see 4.4.1 through 4.4.4). Technology conformance inspection for class T shall be in accordance with the device manufacturer's Quality Management (QM) plan.

<b>STANDARD MICROCIRCUIT DRAWING</b> DEFENSE SUPPLY CENTER COLUMBUS COLUMBUS, OHIO 43216-5000	SIZE <b>A</b>		<b>5962-99511</b>
		REVISION LEVEL <b>B</b>	SHEET <b>10</b>

TABLE IIA. Electrical test requirements.

Test requirements	Subgroups (in accordance with MIL-STD-883, method 5005, table I)	Subgroups (in accordance with MIL-PRF-38535, table III)		
	Device class M	Device class Q	Device class V	Device class T
Interim electrical parameters (see 4.2)	1,7	1,7	1,7	As specified in QM plan
Final electrical parameters (see 4.2)	1,2,3,7,8A,8B, <u>1/</u> 9,10,11	1,2,3,7,8A, <u>1/</u> 8B,9,10,11	1,2,3, <u>2/ 3/</u> 7,8A,8B,9,10, 11	
Group A test requirements (see 4.4)	1,2,3,7,8A,8B, 9,10,11	1,2,3,7,8A,8B, 9,10,11	1,2,3,7,8A, 8B,9,10,11	
Group C end-point electrical parameters (see 4.4)	1,2,3,7,8A,8B, 9,10,11	1,2,3,7,8A,8B, 9,10,11	1,2,3,7,8A, 8B,9,10,11	
Group D end-point electrical parameters (see 4.4)	1,7,9	1,7,9	1,7,9	
Group E end-point electrical parameters (see 4.4)	1,7,9	1,7,9	1,7,9	

1/ PDA applies to subgroup 1 and 7.

2/ PDA applies to subgroups 1, 7, and Δ's.

3/ Delta limits (see table IIB) shall be required and the delta values shall be computed with reference to the zero hour electrical parameters (see table I).

TABLE IIB. Burn-in delta parameters  $T_A = +25^\circ\text{C}$

Parameters	Symbol	Min	Max	Units
Power supply current	I <sub>CCSB</sub> low		175	μA
	I <sub>CCSB</sub> high		175	μA
Input current	I <sub>IL</sub>		1	μA
	I <sub>IH</sub>		1	μA

4.4.1 Group A inspection.

- a. Tests shall be as specified in table IIA herein.
- b. For device classes Q and V, subgroups 7 and 8 shall include verifying the functionality of the device.

4.4.2 Group C inspection. The group C inspection end-point electrical parameters shall be as specified in table IIA herein.

4.4.2.1 Additional criteria for device class M. Steady-state life test conditions, method 1005 of MIL-STD-883:

- a. Test condition A, B, C, or D. The test circuit shall be maintained by the manufacturer under document revision level control and shall be made available to the preparing or acquiring activity upon request. The test circuit shall specify the inputs, outputs, biases, and power dissipation, as applicable, in accordance with the intent specified in test method 1005 of MIL-STD-883.
- b.  $T_A = +125^\circ\text{C}$ , minimum.
- c. Test duration: 1,000 hours, except as permitted by method 1005 of MIL-STD-883.

<b>STANDARD MICROCIRCUIT DRAWING</b> DEFENSE SUPPLY CENTER COLUMBUS COLUMBUS, OHIO 43216-5000	SIZE <b>A</b>		<b>5962-99511</b>
		REVISION LEVEL <b>B</b>	SHEET <b>11</b>

4.4.2.2 Additional criteria for device classes Q, T, and V. The steady-state life test duration, test condition and test temperature, or approved alternatives shall be as specified in the device manufacturer's QM plan in accordance with MIL-PRF-38535. The test circuit shall be maintained under document revision level control by the device manufacturer's TRB in accordance with MIL-PRF-38535 and shall be made available to the acquiring or preparing activity upon request. The test circuit shall specify the inputs, outputs, biases, and power dissipation, as applicable, in accordance with the intent specified in test method 1005 of MIL-STD-883.

4.4.3 Group D inspection. The group D inspection end-point electrical parameters shall be as specified in table IIA herein.

4.4.4 Group E inspection. Group E inspection is required only for parts intended to be marked as radiation hardness assured (see 3.5 herein). RHA levels for device classes M, Q and V shall be as specified in MIL-PRF-38535 and the end-point electrical parameters shall be as specified in table IIA herein. For device class T, the RHA requirements shall be in accordance with the class T radiation requirements of MIL-PRF-38535. The end-point electrical parameters shall be as specified in table I group A subgroups or as modified in the QM plan.

4.4.4.1 Total dose irradiation testing. Total dose irradiation testing shall be performed in accordance with MIL-STD-883 method 1019, condition A and as specified herein. For device class T, the total dose requirements shall be in accordance with the class T radiation requirements of MIL-PRF-38535 (see 1.5 herein).

4.4.4.1.1 Accelerated aging test. Accelerated aging tests shall be performed on all devices requiring a RHA level greater than 5k rads(Si). The post-anneal end-point electrical parameter limits shall be as specified in table I herein and shall be the pre-irradiation end-point electrical parameter limit at 25°C ±5°C. Testing shall be performed at initial qualification and after any design or process changes which may affect the RHA response of the device.

4.4.4.2 Single event phenomena (SEP). When specified in the purchase order or contract SEP testing shall be required on class T and V devices (see 1.5 herein). SEP testing shall be performed on a technology process on the Standard Evaluation Circuit (SEC) or alternate SEP test vehicle as approved by the qualifying activity at initial qualification and after any design or process changes which may affect the upset or latchup characteristics. The recommended test conditions for SEP are as follows:

- a. The ion beam angle of incidence shall be between normal to the die surface and 60° to the normal, inclusive (i.e.  $0^\circ \leq \text{angle} \leq 60^\circ$ ). No shadowing of the ion beam due to fixturing or package related effects is allowed.
- b. The fluence shall be  $\geq 100$  errors or  $\geq 10^6$  ions/cm<sup>2</sup>.
- c. The flux shall be between  $10^2$  and  $10^5$  ions/cm<sup>2</sup>/s. The cross-section shall be verified to be flux independent by measuring the cross-section at two flux rates which differ by at least an order of magnitude.
- d. The particle range shall be  $\geq 20$  microns in silicon.
- e. The test temperature shall be +25°C and the maximum rated operating temperature  $\pm 10^\circ\text{C}$ .
- f. Bias conditions shall be defined by the manufacturer for latchup measurements.
- g. Test four devices with zero failures.

<b>STANDARD MICROCIRCUIT DRAWING</b> DEFENSE SUPPLY CENTER COLUMBUS COLUMBUS, OHIO 43216-5000	SIZE <b>A</b>		<b>5962-99511</b>
		REVISION LEVEL <b>B</b>	SHEET <b>12</b>

5. PACKAGING

5.1 Packaging requirements. The requirements for packaging shall be in accordance with MIL-PRF-38535 for device classes Q, T, and V or MIL-PRF-38535, appendix A for device class M.

6. NOTES

6.1 Intended use. Microcircuits conforming to this drawing are intended for use for Government microcircuit applications (original equipment), design applications, and logistics purposes.

6.1.1 Replaceability. Microcircuits covered by this drawing will replace the same generic device covered by a contractor prepared specification or drawing.

6.1.2 Substitutability. Device class Q devices will replace device class M devices.

6.2 Configuration control of SMD's. All proposed changes to existing SMD's will be coordinated with the users of record for the individual documents. This coordination will be accomplished in accordance with MIL-STD-973 using DD Form 1692, Engineering Change Proposal.

6.3 Record of users. Military and industrial users should inform Defense Supply Center Columbus when a system application requires configuration control and which SMD's are applicable to that system. DSCC will maintain a record of users and this list will be used for coordination and distribution of changes to the drawings. Users of drawings covering microelectronic devices (FSC 5962) should contact DSCC-VA, telephone (614) 692-0525.

6.4 Comments. Comments on this drawing should be directed to DSCC-VA , Columbus, Ohio 43216-5000, or telephone (614) 692-0674.

6.5 Abbreviations, symbols, and definitions. The abbreviations, symbols, and definitions used herein are defined in MIL-PRF-38535 and MIL-HDBK-1331.

6.6 Sources of supply.

6.6.1 Sources of supply for device classes Q, T, and V. Sources of supply for device classes Q, T, and V are listed in QML-38535. The vendors listed in QML-38535 have submitted a certificate of compliance (see 3.6 herein) to DSCC-VA and have agreed to this drawing.

6.6.2 Approved sources of supply for device class M. Approved sources of supply for class M are listed in MIL-HDBK-103. The vendors listed in MIL-HDBK-103 have agreed to this drawing and a certificate of compliance (see 3.6 herein) has been submitted to and accepted by DSCC-VA.

<b>STANDARD MICROCIRCUIT DRAWING</b> DEFENSE SUPPLY CENTER COLUMBUS COLUMBUS, OHIO 43216-5000	SIZE <b>A</b>		<b>5962-99511</b>
		REVISION LEVEL <b>B</b>	SHEET <b>13</b>



APPENDIX A  
APPENDIX A FORMS A PART OF SMD 5962-99511

10.2.4. Die Details. The die details designation shall be a unique letter which designates the die-s physical dimensions, bonding pad location(s) and related electrical function(s), interface materials, and other assembly related information, for each product and variant supplied to this appendix.

10.2.4.1 Die physical dimensions.

Die type	Figure number
01	A-1
02	A-1

10.2.4.2. Die bonding pad locations and electrical functions.

Die type	Figure number
01	A-1
02	A-1

10.2.4.3. Interface materials.

Die type	Figure number
01	A-1
02	A-1

10.2.4.4. Assembly related information.

Die type	Figure number
01	A-1
02	A-1

10.3. Absolute maximum ratings. See paragraph 1.3 within the body of this drawing for details.

10.4 Recommended operating conditions. See paragraph 1.4 within the body of this drawing for details.

20. APPLICABLE DOCUMENTS.

20.1 Government specifications, standards, and handbooks. Unless otherwise specified, the following specification, standard, and handbook of the issue listed in that issue of the Department of Defense Index of Specifications and Standards specified in the solicitation, form a part of this drawing to the extent specified herein.

SPECIFICATION

DEPARTMENT OF DEFENSE

MIL-PRF-38535 - Integrated Circuits, Manufacturing, General Specification for.

STANDARDS

DEPARTMENT OF DEFENSE

MIL-STD-883 - Test Method Standard Microcircuits.

<b>STANDARD MICROCIRCUIT DRAWING</b> DEFENSE SUPPLY CENTER COLUMBUS COLUMBUS, OHIO 43216-5000	SIZE <b>A</b>	<b>5962-99511</b>
	REVISION LEVEL <b>B</b>	SHEET <b>15</b>

APPENDIX A  
APPENDIX A FORMS A PART OF SMD 5962-99511

HANDBOOK

DEPARTMENT OF DEFENSE

MIL-HDBK-103 - List of Standard Microcircuit Drawings (SMD-s).

(Copies of the specification, standard, and handbook required by manufacturers in connection with specific acquisition functions should be obtained from the contracting activity or as directed by the contracting activity).

20.2. Order of precedence. In the event of a conflict between the text of this drawing and the references cited herein, the text of this drawing shall take precedence.

30. REQUIREMENTS

30.1 Item requirements. The individual item requirements for device classes Q and V shall be in accordance with MIL-PRF-38535 and as specified herein or as modified in the device manufacturer-s Quality Management (QM) plan. The modification in the QM plan shall not effect the form, fit or function as described herein.

30.2 Design, construction and physical dimensions. The design, construction and physical dimensions shall be as specified in MIL-PRF-38535 and the manufacturer-s QM plan, for device classes Q and V and herein.

30.2.1 Die physical dimensions. The die physical dimensions shall be as specified in 10.2.4.1 and on figure A-1.

30.2.2 Die bonding pad locations and electrical functions. The die bonding pad locations and electrical functions shall be as specified in 10.2.4.2 and on figure A-1.

30.2.3 Interface materials. The interface materials for the die shall be as specified in 10.2.4.3 and on figure A-1.

30.2.4 Assembly related information. The assembly related information shall be as specified in 10.2.4.4 and figure A-1.

30.2.5 Radiation exposure circuit. The radiation exposure circuit shall be as defined within paragraph 3.2.5. of the body of this document.

30.3 Electrical performance characteristics and post-irradiation parameter limits. Unless otherwise specified herein, the electrical performance characteristics and post-irradiation parameter limits are as specified in table I of the body of this document.

30.4 Electrical test requirements. The wafer probe test requirements shall include functional and parametric testing sufficient to make the packaged die capable of meeting the electrical performance requirements in table I.

30.5 Marking. As a minimum, each unique lot of die, loaded in single or multiple stack of carriers, for shipment to a customer, shall be identified with the wafer lot number, the certification mark, the manufacturer-s identification and the PIN listed in 10.2 herein. The certification mark shall be a "QML" or "Q" as required by MIL-PRF-38535.

30.6 Certification of compliance. For device classes Q and V, a certificate of compliance shall be required from a QML-38535 listed manufacturer in order to supply to the requirements of this drawing (see 60.4 herein). The certificate of compliance submitted to DSCC-VA prior to listing as an approved source of supply for this appendix shall affirm that the manufacturer-s product meets, for device classes Q and V, the requirements of MIL-PRF-38535 and the requirements herein.

30.7 Certificate of conformance. A certificate of conformance as required for device classes Q and V in MIL-PRF-38535 shall be provided with each lot of microcircuit die delivered to this drawing.

<b>STANDARD MICROCIRCUIT DRAWING</b> DEFENSE SUPPLY CENTER COLUMBUS COLUMBUS, OHIO 43216-5000	SIZE <b>A</b>		<b>5962-99511</b>
		REVISION LEVEL <b>B</b>	SHEET <b>16</b>



APPENDIX A  
APPENDIX A FORMS A PART OF SMD 5962-99511

40. QUALITY ASSURANCE PROVISIONS

40.1 Sampling and inspection. For device classes Q and V, die sampling and inspection procedures shall be in accordance with MIL-PRF-38535 or as modified in the device manufacturer's Quality Management (QM) plan. The modifications in the QM plan shall not effect the form, fit or function as described herein.

40.2 Screening. For device classes Q and V, screening shall be in accordance with MIL-PRF-38535, and as defined in the manufacturer's QM plan. As a minimum it shall consist of:

- a) Wafer lot acceptance for Class V product using the criteria defined within MIL-STD-883 test method 5007.
- b) 100% wafer probe (see paragraph 30.4).
- c) 100% internal visual inspection to the applicable class Q or V criteria defined within MIL-STD-883 test method 2010 or the alternate procedures allowed within MIL-STD-883 test method 5004.

40.3 Conformance inspection.

40.3.1 Group E inspection. Group E inspection is required only for parts intended to be identified as radiation assured (see 30.5 herein). RHA levels for device classes Q and V shall be as specified in MIL-PRF-38535. End point electrical testing of packaged die shall be as specified in table IIA herein. Group E tests and conditions are as specified within paragraphs 4.4.4.1, 4.4.4.1.1, and 4.4.4.2.

50. DIE CARRIER

50.1 Die carrier requirements. The requirements for the die carrier shall be accordance with the manufacturer's QM plan or as specified in the purchase order by the acquiring activity. The die carrier shall provide adequate physical, mechanical and electrostatic protection.

60 NOTES

60.1 Intended use. Microcircuit die conforming to this drawing are intended for use in microcircuits built in accordance with MIL-PRF-38535 or MIL-PRF-38534 for government microcircuit applications (original equipment), design applications and logistics purposes.

60.2 Comments. Comments on this appendix should be directed to DSCC-VA, Columbus, Ohio, 43216-5000 or telephone (614)-692-0536.

60.3 Abbreviations, symbols and definitions. The abbreviations, symbols, and definitions used herein are defined within MIL-PRF-38535 and MIL-STD-1331.

60.4 Sources of supply for device classes Q and V. Sources of supply for device classes Q and V are listed in QML-38535. The vendors listed within QML-38535 have submitted a certificate of compliance (see 30.6 herein) to DSCC-VA and have agreed to this drawing.

<b>STANDARD MICROCIRCUIT DRAWING</b> DEFENSE SUPPLY CENTER COLUMBUS COLUMBUS, OHIO 43216-5000	SIZE <b>A</b>	<b>5962-99511</b>
	REVISION LEVEL <b>B</b>	SHEET <b>17</b>

APPENDIX A  
APPENDIX A FORMS A PART OF SMD 5962-99511

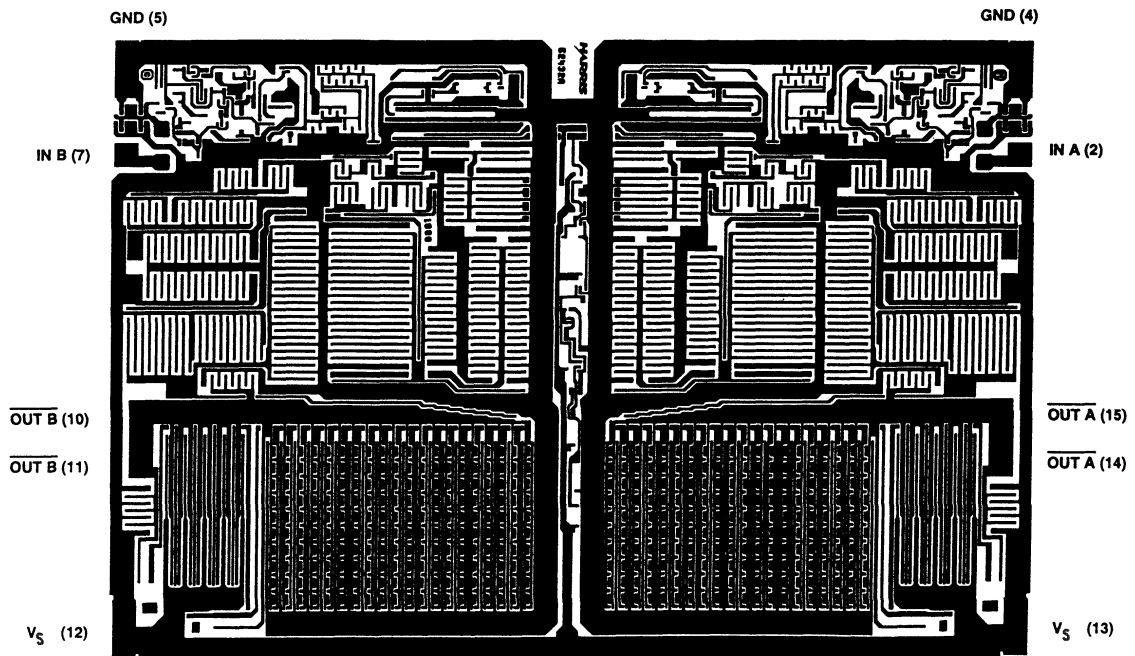

NOTE: Pad numbers reflect terminal numbers when placed in case outline X (see figure 1).

Die physical dimensions.

Die size: 3370 microns x 4890 microns.

Die thickness:  $19 \pm 1$  mils.

Interface materials.

Top metallization: Al Si Cu  $16.0 \text{ k\AA} \pm 2 \text{ k\AA}$

Backside metallization: None

Glassivation.

Type: PSG

Thickness:  $8.0 \text{ k\AA} \pm 1.0 \text{ k\AA}$

Substrate: DI (dielectric isolation)

Assembly related information.

Substrate potential: Unbiased

Special assembly instructions: None

FIGURE A-1. Die bonding pad locations and electrical functions.

<b>STANDARD MICROCIRCUIT DRAWING</b> DEFENSE SUPPLY CENTER COLUMBUS COLUMBUS, OHIO 43216-5000	SIZE <b>A</b>		<b>5962-99511</b>
		REVISION LEVEL <b>B</b>	SHEET <b>18</b>

STANDARD MICROCIRCUIT DRAWING BULLETIN

DATE: 99-06-02

Approved sources of supply for SMD 5962-99511 are listed below for immediate acquisition information only and shall be added to MIL-HDBK-103 and QML-38535 during the next revision. MIL-HDBK-103 and QML-38535 will be revised to include the addition or deletion of sources. The vendors listed below have agreed to this drawing and a certificate of compliance has been submitted to and accepted by DSCC-VA. This bulletin is superseded by the next dated revision of MIL-HDBK-103 and QML-38535.

Standard microcircuit drawing PIN <u>1/</u>	Vendor CAGE number	Vendor similar PIN <u>2/</u>
5962F9951101VXC	34371	HS9-4423RH-Q
5962F9951101QXC	34371	HS9-4423RH-8
5962R9951101TXC	34371	HS9-4423RH-T
5962F9951101V9A	34371	HS0-4423RH-Q
5962F9951102VXC	34371	HS9-4423BRH-Q
5962F9951102QXC	34371	HS9-4423BRH-8
5962R9951102TXC	34371	HS9-4423BRH-T
5962F9951102V9A	34371	HS0-4423BRH-Q

1/ The lead finish shown for each PIN representing a hermetic package is the most readily available from the manufacturer listed for that part. If the desired lead finish is not listed, contact the vendor to determine its availability.

2/ Caution. Do not use this number for item acquisition. Items acquired to this number may not satisfy the performance requirements of this drawing.

Vendor CAGE number

34371

Vendor name and address

Harris Semiconductor  
P.O. Box 883  
Melbourne, FL 32902-0883

The information contained herein is disseminated for convenience only and the Government assumes no liability whatsoever for any inaccuracies in the information bulletin.