

3A, Radiation Hardened, Positive, Ultra-Low Dropout Regulator

ISL75051SEH, ISL75051SRH

The [ISL75051SEH](#), [ISL75051SRH](#) are radiation hardened low-voltage, high-current, single-output LDOs specified for up to 3.0A of continuous output current. These devices operate over an input voltage range of 2.2V to 6.0V and are capable of providing output voltages of 0.8V to 5.0V adjustable based on resistor divider setting. Dropout voltages as low as 65mV can be realized using the device.

The OCP pin allows the short-circuit output current limit threshold to be programmed by means of a resistor from the OCP pin to GND. The OCP setting range is from 0.5A minimum to 8.5A maximum. The resistor sets the constant current threshold for the output under fault conditions. The thermal shutdown disables the output if the device temperature exceeds the specified value. It subsequently enters an ON/OFF cycle until the fault is removed. The ENABLE feature allows the part to be placed into a low current shutdown mode that typically draws about 1µA.

These devices are optimized for fast transient response and single event effects. This reduces the magnitude of SET seen on the output. Additional protection diodes and filters are not needed. These devices are stable with tantalum capacitors as low as 47µF and provide excellent regulation all the way from no load to full load. Programmable soft-start allows the user to program the inrush current by means of the decoupling capacitor value used on the BYP pin.

Applications

- LDO regulator for space application
- DSP, FPGA and µP core power supplies
- Post-regulation of switched mode power supplies
- Down-hole drilling

Features

- DLA SMD [5962-11212](#)
- Output current up to 3.0A at $T_J = +150^\circ\text{C}$
- Output accuracy $\pm 1.5\%$ over MIL temperature range
- Ultra low dropout:
 - 65mV (typical) dropout at 1.0A
 - 225mV (typical) dropout at 3.0A
- SET mitigation with no added filtering/diodes
- Input supply range: 2.2V to 6.0V
- Fast load transient response
- Shutdown current of 1µA (typical)
- Output adjustable using external resistors
- PSRR 66dB (typical) at 1kHz
- Enable and PGood feature
- Programmable soft-start/inrush current limiting
- Over-temperature shutdown and programmable OCP limits
- Stable with 47µF min tantalum capacitor
- Radiation environment
 - High dose rate (50-300rad(Si)/s) 100krad(Si)
 - Low dose rate (0.01rad(Si)/s) 100krad(Si)*

*Product capability established by initial characterization. The "EH" version is acceptance tested on a wafer-by-wafer basis to 50 krad(Si) at low dose rate.

Related Literature

- For a full list of related documents please visit our website
 - [ISL75051SEH](#) product page
 - [ISL75051SRH](#) product page

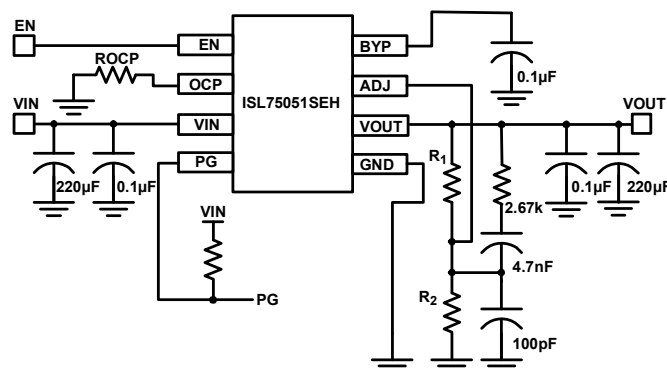

FIGURE 1. TYPICAL APPLICATION

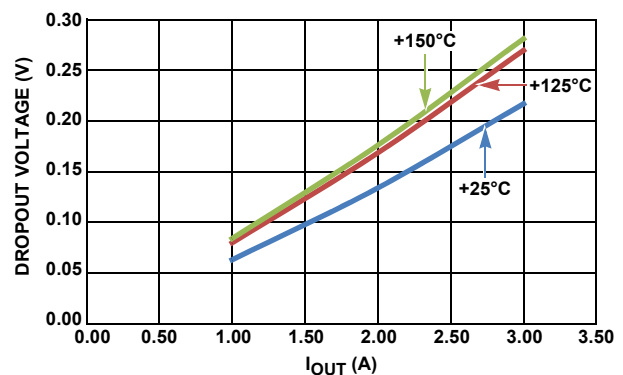

FIGURE 2. DROPOUT vs I_{OUT}

ISL75051SEH, ISL75051SRH

Block Diagram

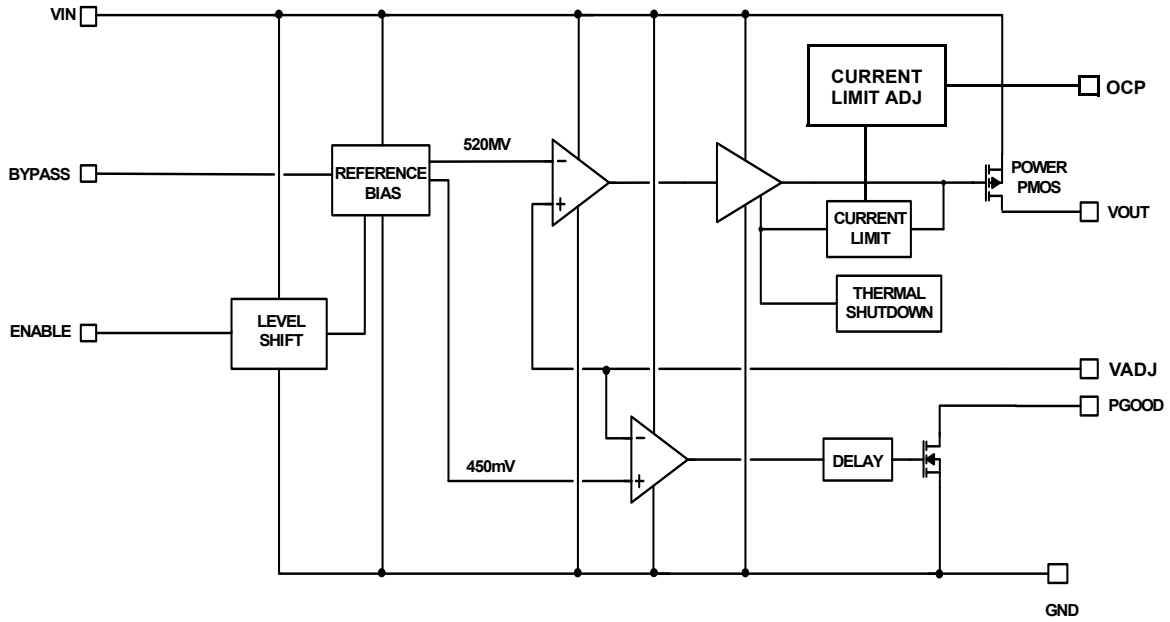

FIGURE 3. BLOCK DIAGRAM

Typical Application

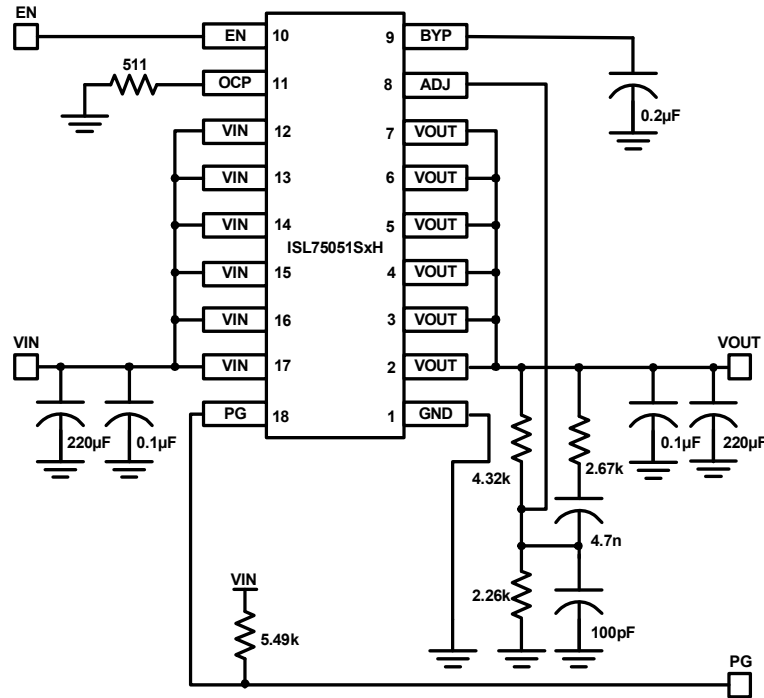
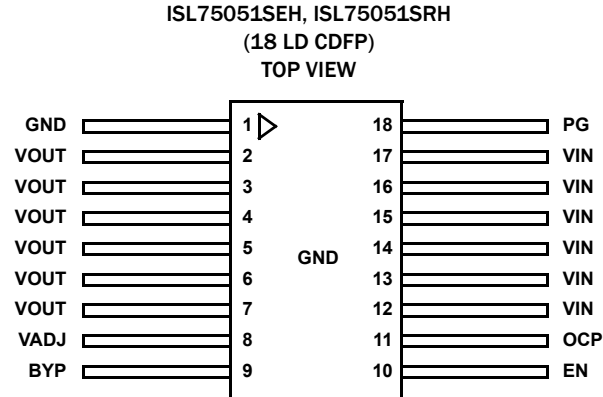

FIGURE 4. TYPICAL APPLICATION

ISL75051SEH, ISL75051SRH

Pin Configuration



NOTE: The ESD triangular mark is indicative of pin #1. It is a part of the device marking and is placed on the lid in the quadrant where pin #1 is located.

Pin Descriptions

PIN NUMBER	PIN NAME	DESCRIPTION
12, 13, 14 15, 16, 17	VIN	Input supply pins.
18	PG	V_{OUT} in regulation signal. Logic low defines when V_{OUT} is not in regulation. Must be grounded if not used.
1	GND	GND pin.
2, 3, 4 5, 6, 7	VOUT	Output voltage pins.
8	VADJ	VADJ pin allows V_{OUT} to be programmed with an external resistor divider.
9	BYP	To filter the internal reference, connect a 0.1 μ F capacitor from BYP pin to GND.
10	EN	VIN independent chip enable. TTL and CMOS compatible.
11	OCP	Allows current limit to be programmed with an external resistor.
Top Lid	GND	The top lid is connected to GND pin of the package.

ISL75051SEH, ISL75051SRH

Ordering Information

ORDERING NUMBER (Notes 1, 2)	PART NUMBER	TEMP RANGE (°C)	PACKAGE (RoHS COMPLIANT)	PKG DWG. #
5962R1121202VXC	ISL75051SEHVF	-55 to +125	18 Ld CDFP	K18.D
5962R1121202V9A	ISL75051SEHVX	-55 to +125	Die	
5962R1121202VYC	ISL75051SEHVFE	-55 to +125	18 Ld CDFP with bottom metal	K18.E
N/A	ISL75051SEHFE/PROTO	-55 to +125	18 Ld CDFP with bottom metal	K18.E
N/A	ISL75051SEHX/SAMPLE	-55 to +125	Die Sample	
5962R1121201VXC	ISL75051SRHVF	-55 to +125	18 Ld CDFP	K18.D
5962R1121201QXC	ISL75051SRHQF	-55 to +125	18 Ld CDFP	K18.D
5962R1121201V9A	ISL75051SRHVX	-55 to +125	Die	
N/A	ISL75051SRHX/SAMPLE	-55 to +125	Die Sample	
N/A	ISL75051SRHF/PROTO	-55 to +125	18 Ld CDFP	K18.D
N/A	ISL75051SRHEVAL1Z	Evaluation Board		

NOTES:

1. These Intersil Pb-free Hermetic packaged products employ 100% Au plate - e4 termination finish, which is RoHS compliant and compatible with both SnPb and Pb-free soldering operations.
2. Specifications for Rad Hard QML devices are controlled by the Defense Logistics Agency Land and Maritime (DLA). The SMD numbers listed must be used when ordering.

ISL75051SEH, ISL75051SRH

Absolute Maximum Ratings

VIN Relative to GND (Note 3)	-0.3 to + 6.7V
VOOUT Relative to GND (Note 3)	-0.3 to + 6.7V
PG, EN, OCP/ADJ Relative to GND (Note 3)	-0.3 to + 6.7VDC
Junction Temperature (Tj)	+175°C
ESD Rating	
Human Body Model (Tested per MIL-PRF-883 3015.7)	2.5kV
Machine Model (Tested per JESD22-A115-A)	250V
Charged Device Model (Tested per JESD22-C101D)	1kV

Recommended Operating Conditions (Note 4)

Ambient Temperature Range (TA)	-55°C to +125°C
Junction Temperature (Tj) (Note 3)	+150°C
VIN Relative to GND	2.2V to 6.0V
VOOUT Range	0.8V to 5.0V
PG, EN, OCP/ADJ Relative to GND	0V to +6.0V

CAUTION: Do not operate at or near the maximum ratings listed for extended periods of time. Exposure to such conditions may adversely impact product reliability and result in failures not covered by warranty.

NOTES:

- Extended operation at these conditions may compromise reliability. Exceeding these limits will result in damage. Recommended operating conditions define limits where specifications are guaranteed.
- Refer to "Thermal Guidelines" on page 17.
- Product capability established by initial characterization. The "EH" version is acceptance tested on a wafer-by-wafer basis to 50 krad(Si) at low dose rate.
- Specify EVAL test conditions for SET/SEB/SEL here.
- θ_{JA} is measured in free air with the component mounted on a high effective thermal conductivity test board with "direct attach" features. See Tech Brief TB379.
- For θ_{JC} , the "case temp" location is the center of the package underside.
- The device can work down to $V_{OUT} = 0.8V$; however, the SET performance of $< \pm 5\%$ at $LET = 86MeV \cdot cm^2/mg$ is established at $V_{OUT} = >1.5V$ only. SET tests performed with 220 μF 10V 25m Ω and 0.1 μF CDR04 capacitor on the input and output.

Electrical Specifications Unless otherwise noted, all parameters are established over the following specified conditions: $V_{IN} = V_{OUT} + 0.4V$, $V_{OUT} = 1.8V$, $C_{IN} = C_{OUT} = 220\mu F$ 25m Ω and 0.1 μF X7R, $T_J = +25^\circ C$, $I_L = 0A$. Applications must follow thermal guidelines of the package to determine worst-case junction temperature (see Note 13). **Boldface limits apply across the operating temperature range, -55°C to +125°C.** Pulse load techniques used by ATE to ensure $T_J = T_A$ defines established limits.

PARAMETER	SYMBOL	TEST CONDITIONS	MIN (Note 10)	TYP	MAX (Note 10)	UNIT
DC CHARACTERISTICS						
DC Output Voltage Accuracy	VOOUT	VOOUT resistor adjust to 0.52V, 1.5V and 1.8V				
		2.2V < VIN < 3.6V; 0A < ILOAD < 3.0A	-1.5	0.2	1.5	%
		VOOUT resistor adjust to 5.0V				
		VOOUT + 0.4V < VIN < 6.0V; 0A < ILOAD < 3.0A	-1.5	0.2	1.5	%
VADJ Pin Voltage	VADJ	2.2V < VIN < 6.0V; ILOAD = 0A	514.8	520.0	525.2	mV
BYP Pin	VBYP	2.2V < VIN < 6.0V; ILOAD = 0A		520		mV
DC Input Line Regulation		2.2V < VIN < 3.6V, VOOUT = 1.5V, +25°C and -55°C (Note 11)		1.13	3.50	mV
DC Input Line Regulation		2.2V < VIN < 3.6V, VOOUT = 1.5V, +125°C (Note 11)		1.13	8.00	mV
DC Input Line Regulation		2.2V < VIN < 3.6V, VOOUT = 1.8V, +25°C and -55°C (Note 11)		1.62	3.50	mV
DC Input Line Regulation		2.2V < VIN < 3.6V, VOOUT = 1.8V, +125°C (Note 11)		1.62	10.50	mV
DC Input Line Regulation		VOOUT + 0.4V < VIN < 6.0V, VOOUT = 5.0V (Note 11)		12.50	20.00	mV
DC Output Load Regulation		VOOUT = 1.5V; 0A < ILOAD < 3.0A, VIN = VOOUT + 0.4V (Note 11)	-4.0	-0.8	-0.1	mV

Thermal Information

Thermal Resistance (Typical)	θ_{JA} (°C/W)	θ_{JC} (°C/W)
18 Ld CDFP Package (Notes 7, 8)	28	4
18 Ld CDFP Package with Bottom Metal and Solder Mount (Notes 7, 8)	24	3.3
Storage Temperature Range	-65°C to +150°C	

Radiation Information

Maximum Total Dose	
Dose Rate = 50-300rad(Si)/s	100krad (Si)
Dose Rate = 0.01rad(Si)/s (Note 5)	100krad (Si)
SEE Performance	
SET (VOOUT < ±5% During Events) (Note 6)	86MeV • cm ² /mg
SEL/SEB (No Latch-Up/Burnout)	86MeV • cm ² /mg

ISL75051SEH, ISL75051SRH

Electrical Specifications Unless otherwise noted, all parameters are established over the following specified conditions: $V_{IN} = V_{OUT} + 0.4V$, $V_{OUT} = 1.8V$, $C_{IN} = C_{OUT} = 220\mu F$ 25m Ω and 0.1 μF X7R, $T_J = +25^\circ C$, $I_L = 0A$. Applications must follow thermal guidelines of the package to determine worst-case junction temperature (see [Note 13](#)). **Boldface limits apply across the operating temperature range, $-55^\circ C$ to $+125^\circ C$.** Pulse load techniques used by ATE to ensure $T_J = T_A$ defines established limits. (Continued)

PARAMETER	SYMBOL	TEST CONDITIONS	MIN (Note 10)	TYP	MAX (Note 10)	UNIT
DC Output Load Regulation		$V_{OUT} = 1.8V$; $0A < I_{LOAD} < 3.0A$, $V_{IN} = V_{OUT} + 0.4V$ (Note 11)	-4.00	-1.20	-0.05	mV
DC Output Load Regulation		$V_{OUT} = 5.0V$; $0A < I_{LOAD} < 3.0A$, $V_{IN} = V_{OUT} + 0.4V$ (Note 11)	-15.00	-6.00	-0.05	mV
VADJ Input Current		$V_{ADJ} = 0.5V$			1	μA
Ground Pin Current	I_Q	$V_{OUT} = 1.5V$; $I_{LOAD} = 0A$, $V_{IN} = 2.2V$		11	12	mA
Ground Pin Current	I_Q	$V_{OUT} = 5.0V$; $I_{LOAD} = 0A$, $V_{IN} = 6.0V$		16	18	mA
Ground Pin Current	I_Q	$V_{OUT} = 1.5V$; $I_{LOAD} = 3.0A$, $V_{IN} = 2.2V$		11	13	mA
Ground Pin Current	I_Q	$V_{OUT} = 5.0V$; $I_{LOAD} = 3.0A$, $V_{IN} = 6.0V$		16	18	mA
Ground Pin Current in Shutdown	I_{SHDN}	ENABLE Pin = 0V, $V_{IN} = 6.0V$		1	10	μA
Dropout Voltage	V_{DO}	$I_{LOAD} = 1.0A$, $V_{OUT} = 2.5V$ (Note 12)		65	100	mV
Dropout Voltage	V_{DO}	$I_{LOAD} = 2.0A$, $V_{OUT} = 2.5V$ (Note 12)		140	200	mV
Dropout Voltage	V_{DO}	$I_{LOAD} = 3.0A$, $V_{OUT} = 2.5V$ (Note 12)		225	300	mV
Output Short-Circuit Current	ISCL	$V_{OUT} = 0V$, $V_{IN} = 2.2V$, $R_{SET} = 5.11k$		1.1		A
Output Short-Circuit Current	ISCL	$V_{OUT} = 0V$, $V_{IN} = 6.0V$, $R_{SET} = 5.11k$		1.2		A
Output Short-Circuit Current	ISCH	$V_{OUT} = 0V$, $V_{IN} = 2.2V$, $R_{SET} = 511\Omega$		5.7		A
Output Short-Circuit Current	ISCH	$V_{OUT} = 0V$, $V_{IN} = 6.0V$, $R_{SET} = 511\Omega$		6.2		A
Thermal Shutdown Temperature	TSD	$V_{OUT} + 0.4V < V_{IN} < 6.0V$		175		$^\circ C$
Thermal Shutdown Hysteresis (Rising Threshold)	TSDn	$V_{OUT} + 0.4V < V_{IN} < 6.0V$		25		$^\circ C$
AC CHARACTERISTICS						
Input Supply Ripple Rejection	PSRR	$V_{P-P} = 300mV$, $f = 1kHz$, $I_{LOAD} = 3A$; $V_{IN} = 2.5V$, $V_{OUT} = 1.8V$	42	66		dB
Input Supply Ripple Rejection	PSRR	$V_{P-P} = 300mV$, $f = 100kHz$, $I_{LOAD} = 3A$; $V_{IN} = 2.5V$, $V_{OUT} = 1.8V$		30		dB
Phase Margin	PM	$V_{OUT} = 1.8V$, $C_L = 220\mu F$ Tantalum		70		dB
Gain Margin	GM	$V_{OUT} = 1.8V$, $C_L = 220\mu F$ Tantalum		16		dB
Output Noise Voltage		$I_{LOAD} = 10mA$, $BW = 300Hz < f < 300kHz$, BYPASS to GND capacitor = 0.2 μF		100		μV_{RMS}
DEVICE START-UP CHARACTERISTICS: ENABLE PIN						
Rising Threshold		$2.2V < V_{IN} < 6.0V$	0.6	0.9	1.2	V
Falling Threshold		$2.2V < V_{IN} < 6.0V$	0.47	0.70	0.90	V
Enable Pin Leakage Current		$V_{IN} = 6.0V$, EN = 6.0V			1	μA
Enable Pin Propagation Delay		$V_{IN} = 2.2V$, EN rise to I_{OUT} rise	225	300	450	μs
Hysteresis		Must be independent of V_{IN} ; $2.2V < V_{IN} < 6.0V$	90	200	318	mV
DEVICE START-UP CHARACTERISTICS: PG PIN						
PG Rising Threshold		$2.2V < V_{IN} < 6.0V$	85	90	96	%
PG Falling Threshold		$2.2V < V_{IN} < 6.0V$	82	88	93	%
PG Hysteresis		$2.2V < V_{IN} < 6.0V$	2.5	3.2	4.0	% V_{OUT}
PG Low Voltage		$I_{SINK} = 1mA$		35	100	mV

ISL75051SEH, ISL75051SRH

Electrical Specifications Unless otherwise noted, all parameters are established over the following specified conditions: $V_{IN} = V_{OUT} + 0.4V$, $V_{OUT} = 1.8V$, $C_{IN} = C_{OUT} = 220\mu F$ 25m Ω and 0.1 μF X7R, $T_J = +25^\circ C$, $I_L = 0A$. Applications must follow thermal guidelines of the package to determine worst-case junction temperature (see [Note 13](#)). **Boldface limits apply across the operating temperature range, -55°C to +125°C.** Pulse load techniques used by ATE to ensure $T_J = T_A$ defines established limits. (Continued)

PARAMETER	SYMBOL	TEST CONDITIONS	MIN (Note 10)	TYP	MAX (Note 10)	UNIT
PG Low Voltage		$I_{SINK} = 6mA$		185	400	mV
PG Leakage Current		$V_{IN} = 6.0V$, PG = 6.0V		0.01	1.00	μA

NOTES:

- Parameters with MIN and/or MAX limits are 100% tested at -55°C, +25°C and +125°C, unless otherwise specified. Temperature limits established by characterization and are not production tested.
- Line and Load Regulation done under pulsed condition for $T < 10ms$.
- Droput is defined as the difference between the supply V_{IN} and V_{OUT} , when the supply produces a 2% drop in V_{OUT} from its nominal value. Data measured within a 3ms period.
- Please refer to ["Applications Information" on page 15](#) of the datasheet and Tech Brief [TB379](#).

High Dose Rate Post Radiation Characteristics $T_A = +25^\circ C$, unless otherwise noted. This data is typical test data post radiation exposure at a rate of 50 to 300rad(Si)/s. This data is intended to show typical parameter shifts due to high dose rate radiation (see [Note 14](#)). These are not limits nor are they guaranteed.

ITEM #	DESCRIPTION	CONDITION	0k RAD	100k RAD	UNIT
1	DC Output Voltage Accuracy	$V_{OUT} = 0.52V$; $V_{IN} = 2.2V$; $I_{OUT} = 0A$	0.520575	0.520975	V
2	DC Output Voltage Accuracy	$V_{OUT} = 0.52V$; $V_{IN} = 2.2V$; $I_{OUT} = 3A$	0.520000	0.520300	V
3	DC Output Voltage Accuracy	$V_{OUT} = 0.52V$; $V_{IN} = 3.6V$; $I_{OUT} = 0A$	0.520650	0.520813	V
4	DC Output Voltage Accuracy	$V_{OUT} = 0.52V$; $V_{IN} = 3.6V$; $I_{OUT} = 3A$	0.519963	0.520113	V
5	DC Output Voltage Accuracy	$V_{OUT} = 1.5V$; $V_{IN} = 2.2V$; $I_{OUT} = 0A$	1.500813	1.501325	V
6	DC Output Voltage Accuracy	$V_{OUT} = 1.5V$; $V_{IN} = 2.2V$; $I_{OUT} = 3A$	1.499250	1.499800	V
7	DC Output Voltage Accuracy	$V_{OUT} = 1.5V$; $V_{IN} = 3.6V$; $I_{OUT} = 0A$	1.500550	1.500938	V
8	DC Output Voltage Accuracy	$V_{OUT} = 1.5V$; $V_{IN} = 3.6V$; $I_{OUT} = 3A$	1.499075	1.499388	V
9	DC Output Voltage Accuracy	$V_{OUT} = 1.8V$; $V_{IN} = 2.2V$; $I_{OUT} = 0A$	1.802288	1.803613	V
10	DC Output Voltage Accuracy	$V_{OUT} = 1.8V$; $V_{IN} = 2.2V$; $I_{OUT} = 3A$	1.800900	1.801825	V
11	DC Output Voltage Accuracy	$V_{OUT} = 1.8V$; $V_{IN} = 3.6V$; $I_{OUT} = 0A$	1.802900	1.803338	V
12	DC Output Voltage Accuracy	$V_{OUT} = 1.8V$; $V_{IN} = 3.6V$; $I_{OUT} = 3A$	1.801175	1.801550	V
13	DC Output Voltage Accuracy	$V_{OUT} = 5.0V$; $V_{IN} = 5.4V$; $I_{OUT} = 0A$	5.018250	5.018850	V
14	DC Output Voltage Accuracy	$V_{OUT} = 5.0V$; $V_{IN} = 5.4V$; $I_{OUT} = 3A$	5.013050	5.013450	V
15	DC Output Voltage Accuracy	$V_{OUT} = 5.0V$; $V_{IN} = 6.0V$; $I_{OUT} = 0A$	5.023838	5.024188	V
16	DC Output Voltage Accuracy	$V_{OUT} = 5.0V$; $V_{IN} = 6.0V$; $I_{OUT} = 3A$	5.016550	5.016763	V
17	VADJ Pin Voltage	$V_{OUT} = 0.52V$; $V_{IN} = 2.2V$	0.520625	0.521000	V
18	VADJ Pin Voltage	$V_{OUT} = 0.52V$; $V_{IN} = 3.6V$	0.520700	0.520863	V
19	VADJ Pin Voltage	$V_{OUT} = 0.52V$; $V_{IN} = 5.5V$	0.521125	0.521200	V
20	VADJ Pin Voltage	$V_{OUT} = 1.5V$; $V_{IN} = 2.2V$	0.520800	0.521013	V
21	VADJ Pin Voltage	$V_{OUT} = 1.5V$; $V_{IN} = 3.6V$	0.520688	0.520838	V
22	VADJ Pin Voltage	$V_{OUT} = 1.5V$; $V_{IN} = 5.5V$	0.521025	0.521113	V
23	VADJ Pin Voltage	$V_{OUT} = 1.8V$; $V_{IN} = 2.2V$	0.520563	0.520925	V
24	VADJ Pin Voltage	$V_{OUT} = 1.8V$; $V_{IN} = 3.6V$	0.520688	0.520838	V
25	VADJ Pin Voltage	$V_{OUT} = 1.8V$; $V_{IN} = 5.5V$	0.521038	0.521100	V
26	VADJ Pin Voltage	$V_{OUT} = 5.0V$; $V_{IN} = 5.4V$	0.521000	0.521088	V
27	VADJ Pin Voltage	$V_{OUT} = 5.0V$; $V_{IN} = 6.0V$	0.521575	0.521625	V
28	DC Input Line Regulation	$2.2V < V_{IN} < 3.6V$, $V_{OUT} = 1.5V$	-0.257100	-0.408960	mV
29	DC Input Line Regulation	$2.2V < V_{IN} < 3.6V$, $V_{OUT} = 1.8V$	0.611613	-0.281990	mV
30	DC Input Line Regulation	$V_{OUT} + 0.4V < V_{IN} < 6.0V$, $V_{OUT} = 5.0V$	5.600700	5.313688	mV

ISL75051SEH, ISL75051SRH

High Dose Rate Post Radiation Characteristics TA = +25°C, unless otherwise noted. This data is typical test data post radiation exposure at a rate of 50 to 300rad(Si)/s. This data is intended to show typical parameter shifts due to high dose rate radiation (see [Note 14](#)). These are not limits nor are they guaranteed. (Continued)

ITEM #	DESCRIPTION	CONDITION	0k RAD	100k RAD	UNIT
31	DC Output Load Regulation	V _{OUT} = 1.5V; 0A < I _{LOAD} < 3.0A, V _{IN} = V _{OUT} + 0.4V	-1.559875	-1.549760	mV
32	DC Output Load Regulation	V _{OUT} = 1.8V; 0A < I _{LOAD} < 3.0A, V _{IN} = V _{OUT} + 0.4V	-1.390263	-1.784640	mV
33	DC Output Load Regulation	V _{OUT} = 5.0V; 0A < I _{LOAD} < 3.0A, V _{IN} = V _{OUT} + 0.4V	-5.201513	-5.418710	mV
34	Feedback Input Current	V _{ADJ} = 0.5V	-0.036650	-0.040980	μA
35	Ground Pin Current	V _{OUT} = 1.5V; I _{LOAD} = 0A, V _{IN} = 2.2V	10.715763	10.758810	mA
36	Ground Pin Current	V _{OUT} = 1.5V; I _{LOAD} = 3.0A, V _{IN} = 2.2V	12.016163	12.067510	mA
37	Ground Pin Current	V _{OUT} = 5.0V; I _{LOAD} = 0A, V _{IN} = 6.0V	15.796488	15.781190	mA
38	Ground Pin Current	V _{OUT} = 5.0V; I _{LOAD} = 3.0A, V _{IN} = 6.0V	17.178913	17.166440	mA
39	Ground Pin Current in Shutdown	ENABLE Pin = 0V, V _{IN} = 6.0V	0.811625	0.752100	μA
40	Dropout Voltage	I _{LOAD} = 1.0A, V _{OUT} = 2.5V	62.588600	63.660340	mV
41	Dropout Voltage	I _{LOAD} = 2.0A, V _{OUT} = 2.5V	134.520040	135.703500	mV
42	Dropout Voltage	I _{LOAD} = 3.0A, V _{OUT} = 2.5V	215.603360	216.651900	mV
43	Output Short-Circuit Current	V _{OUT} = 0V, V _{IN} = 2.2V, R _{SET} = 5.11k	1.204063	1.323238	A
44	Output Short-Circuit Current	V _{OUT} = 0V, V _{IN} = 2.2V, R _{SET} = 511Ω	5.903613	6.058613	A
45	Output Short-Circuit Current	V _{OUT} = 0V, V _{IN} = 6.0V, R _{SET} = 5.11k	1.333325	1.439638	A
46	Output Short-Circuit Current	V _{OUT} = 0V, V _{IN} = 6.0V, R _{SET} = 511Ω	6.389913	6.635563	A
47	PSRR	V _{P-P} = 300mV, f = 1kHz, I _{LOAD} = 3A; V _{IN} = 2.5V, V _{OUT} = 1.8V	65.428638	66.410750	dB
48	Enable Rising Threshold	V _{IN} = 2.2V	0.863700	0.824150	V
49	Enable Rising Threshold	V _{IN} = 6.0V	0.911300	0.875263	V
50	Enable Falling Threshold	V _{IN} = 2.2V	0.678400	0.636800	V
51	Enable Falling Threshold	V _{IN} = 6.0V	0.724475	0.684400	V
52	Enable Pin Leakage Current	V _{IN} = 6.0V, EN = 0V	-0.028513	-0.029950	μA
53	Enable Pin Leakage Current	V _{IN} = 6.0V, EN = 6.0V	-0.030638	-0.038110	μA
54	Enable Hysteresis	V _{IN} = 2.2V	185.370000	187.374000	mV
55	Enable Hysteresis	V _{IN} = 6.0V	186.874000	190.881600	mV
56	Enable Pin Propagation Delay	V _{IN} = 2.2V, EN rise to I _{OUT} rise	305.015280	290.839200	μs
57	PG Rising Threshold	V _{IN} = 2.2V	89.542938	88.811230	%
58	PG Rising Threshold	V _{IN} = 6.0V	91.083838	90.396230	%
59	PG Falling Threshold	V _{IN} = 2.2V	86.793125	86.074360	%
60	PG Falling Threshold	V _{IN} = 6.0V	87.840925	87.165790	%
61	PG Hysteresis	V _{IN} = 2.2V	2.749825	2.736875	%
62	PG Hysteresis	V _{IN} = 6.0V	3.242925	3.230450	%
63	PG Low Voltage	I _{SINK} = 1mA	31.426938	31.570940	mV
64	PG Low Voltage	I _{SINK} = 6mA	177.107950	178.578800	mV
65	PG Leakage Current	V _{IN} = 6.0V, PG = 6.0V	-0.001550	-0.001560	μA

ISL75051SEH, ISL75051SRH

Low Dose Rate Post Radiation Characteristics $T_A = +25^\circ\text{C}$, unless otherwise noted. This data is typical test data post radiation exposure at a rate of 10mrad(Si)/s. This data is intended to show typical parameter shifts due to low dose rate radiation (see [Note 14](#)). These are not limits nor are they guaranteed. This data applies only to the ISL75051SEH.

ITEM #	DESCRIPTION	CONDITION	0k RAD	50k RAD	100k RAD	UNIT
1	DC Output Voltage Accuracy	$V_{OUT} = 0.52\text{V}; V_{IN} = 2.2\text{V}; I_{OUT} = 0\text{A}$	0.521050	0.521150	0.521600	V
2	DC Output Voltage Accuracy	$V_{OUT} = 0.52\text{V}; V_{IN} = 2.2\text{V}; I_{OUT} = 3\text{A}$	0.520500	0.520600	0.520950	V
3	DC Output Voltage Accuracy	$V_{OUT} = 0.52\text{V}; V_{IN} = 3.6\text{V}; I_{OUT} = 0\text{A}$	0.521050	0.521350	0.521750	V
4	DC Output Voltage Accuracy	$V_{OUT} = 0.52\text{V}; V_{IN} = 3.6\text{V}; I_{OUT} = 3\text{A}$	0.520450	0.520600	0.521000	V
5	DC Output Voltage Accuracy	$V_{OUT} = 1.5\text{V}; V_{IN} = 2.2\text{V}; I_{OUT} = 0\text{A}$	1.502450	1.503050	1.503200	V
6	DC Output Voltage Accuracy	$V_{OUT} = 1.5\text{V}; V_{IN} = 2.2\text{V}; I_{OUT} = 3\text{A}$	1.500950	1.501400	1.502100	V
7	DC Output Voltage Accuracy	$V_{OUT} = 1.5\text{V}; V_{IN} = 3.6\text{V}; I_{OUT} = 0\text{A}$	1.501950	1.502900	1.503650	V
8	DC Output Voltage Accuracy	$V_{OUT} = 1.5\text{V}; V_{IN} = 3.6\text{V}; I_{OUT} = 3\text{A}$	1.500500	1.501400	1.502150	V
9	DC Output Voltage Accuracy	$V_{OUT} = 1.8\text{V}; V_{IN} = 2.2\text{V}; I_{OUT} = 0\text{A}$	1.804150	1.805050	1.806100	V
10	DC Output Voltage Accuracy	$V_{OUT} = 1.8\text{V}; V_{IN} = 2.2\text{V}; I_{OUT} = 3\text{A}$	1.802850	1.803650	1.804800	V
11	DC Output Voltage Accuracy	$V_{OUT} = 1.8\text{V}; V_{IN} = 3.6\text{V}; I_{OUT} = 0\text{A}$	1.804450	1.805850	1.806600	V
12	DC Output Voltage Accuracy	$V_{OUT} = 1.8\text{V}; V_{IN} = 3.6\text{V}; I_{OUT} = 3\text{A}$	1.802850	1.804100	1.804900	V
13	DC Output Voltage Accuracy	$V_{OUT} = 5.0\text{V}; V_{IN} = 5.4\text{V}; I_{OUT} = 0\text{A}$	5.022600	5.027250	5.028500	V
14	DC Output Voltage Accuracy	$V_{OUT} = 5.0\text{V}; V_{IN} = 5.4\text{V}; I_{OUT} = 3\text{A}$	5.017200	5.022200	5.023350	V
15	DC Output Voltage Accuracy	$V_{OUT} = 5.0\text{V}; V_{IN} = 6.0\text{V}; I_{OUT} = 0\text{A}$	5.028050	5.032500	5.034350	V
16	DC Output Voltage Accuracy	$V_{OUT} = 5.0\text{V}; V_{IN} = 6.0\text{V}; I_{OUT} = 3\text{A}$	5.020950	5.025500	5.027050	V
17	VADJ Pin Voltage	$V_{OUT} = 0.52\text{V}; V_{IN} = 2.2\text{V}$	0.521150	0.521300	0.521600	V
18	VADJ Pin Voltage	$V_{OUT} = 0.52\text{V}; V_{IN} = 3.6\text{V}$	0.521150	0.521400	0.521700	V
19	VADJ Pin Voltage	$V_{OUT} = 0.52\text{V}; V_{IN} = 5.5\text{V}$	0.521550	0.521800	0.522150	V
20	VADJ Pin Voltage	$V_{OUT} = 1.5\text{V}; V_{IN} = 2.2\text{V}$	0.521400	0.521500	0.521550	V
21	VADJ Pin Voltage	$V_{OUT} = 1.5\text{V}; V_{IN} = 3.6\text{V}$	0.521150	0.521400	0.521700	V
22	VADJ Pin Voltage	$V_{OUT} = 1.5\text{V}; V_{IN} = 5.5\text{V}$	0.521450	0.521800	0.522050	V
23	VADJ Pin Voltage	$V_{OUT} = 1.8\text{V}; V_{IN} = 2.2\text{V}$	0.521050	0.521200	0.521550	V
24	VADJ Pin Voltage	$V_{OUT} = 1.8\text{V}; V_{IN} = 3.6\text{V}$	0.521150	0.521400	0.521750	V
25	VADJ Pin Voltage	$V_{OUT} = 1.8\text{V}; V_{IN} = 5.5\text{V}$	0.521450	0.521800	0.522000	V
26	VADJ Pin Voltage	$V_{OUT} = 5.0\text{V}; V_{IN} = 5.4\text{V}$	0.521400	0.521800	0.521950	V
27	VADJ Pin Voltage	$V_{OUT} = 5.0\text{V}; V_{IN} = 6.0\text{V}$	0.522000	0.522250	0.522600	V
28	DC Input Line Regulation	$2.2\text{V} < V_{IN} < 3.6\text{V}, V_{OUT} = 1.5\text{V}$	-0.284500	-0.176150	0.158400	mV
29	DC Input Line Regulation	$2.2\text{V} < V_{IN} < 3.6\text{V}, V_{OUT} = 1.8\text{V}$	0.520000	0.551100	0.356200	mV
30	DC Input Line Regulation	$V_{OUT} + 0.4\text{V} < V_{IN} < 6.0\text{V}, V_{OUT} = 5.0\text{V}$	5.792850	5.296750	5.315300	mV
31	DC Output Load Regulation	$V_{OUT} = 1.5\text{V}; 0\text{A} < I_{LOAD} < 3.0\text{A}, V_{IN} = V_{OUT} + 0.4\text{V}$	-1.525700	-1.571300	-1.219950	mV
32	DC Output Load Regulation	$V_{OUT} = 1.8\text{V}; 0\text{A} < I_{LOAD} < 3.0\text{A}, V_{IN} = V_{OUT} + 0.4\text{V}$	-1.314200	-1.447200	-1.372050	mV
33	DC Output Load Regulation	$V_{OUT} = 5.0\text{V}; 0\text{A} < I_{LOAD} < 3.0\text{A}, V_{IN} = V_{OUT} + 0.4\text{V}$	-5.026850	-5.007050	-4.816750	mV
34	Feedback Input Current	$V_{ADJ} = 0.5\text{V}$	-0.011650	-0.030300	-0.036550	μA
35	Ground Pin Current	$V_{OUT} = 1.5\text{V}; I_{LOAD} = 0\text{A}, V_{IN} = 2.2\text{V}$	10.665000	10.658900	10.621750	mA
36	Ground Pin Current	$V_{OUT} = 1.5\text{V}; I_{LOAD} = 3.0\text{A}, V_{IN} = 2.2\text{V}$	11.977100	12.015600	11.948450	mA
37	Ground Pin Current	$V_{OUT} = 5.0\text{V}; I_{LOAD} = 0\text{A}, V_{IN} = 6.0\text{V}$	15.814550	15.840150	15.771750	mA
38	Ground Pin Current	$V_{OUT} = 5.0\text{V}; I_{LOAD} = 3.0\text{A}, V_{IN} = 6.0\text{V}$	17.223200	17.224650	17.189200	mA

ISL75051SEH, ISL75051SRH

Low Dose Rate Post Radiation Characteristics $T_A = +25^\circ\text{C}$, unless otherwise noted. This data is typical test data post radiation exposure at a rate of 10mrad(Si)/s. This data is intended to show typical parameter shifts due to low dose rate radiation (see [Note 14](#)). These are not limits nor are they guaranteed. This data applies only to the ISL75051SEH. (Continued)

ITEM #	DESCRIPTION	CONDITION	0k RAD	50k RAD	100k RAD	UNIT
39	Ground Pin Current in Shutdown	ENABLE Pin = 0V, $V_{IN} = 6.0\text{V}$	0.430300	0.601500	0.707900	μA
40	Dropout Voltage	$I_{LOAD} = 1.0\text{A}$, $V_{OUT} = 2.5\text{V}$	62.801250	62.431600	65.466000	mV
41	Dropout Voltage	$I_{LOAD} = 2.0\text{A}$, $V_{OUT} = 2.5\text{V}$	132.799650	133.294300	138.742500	mV
42	Dropout Voltage	$I_{LOAD} = 3.0\text{A}$, $V_{OUT} = 2.5\text{V}$	214.477050	213.033000	221.517950	mV
43	Output Short-Circuit Current	$V_{OUT} = 0\text{V}$, $V_{IN} = 2.2\text{V}$, $R_{SET} = 5.11\text{k}$	1.178050	1.199850	1.224300	A
44	Output Short-Circuit Current	$V_{OUT} = 0\text{V}$, $V_{IN} = 2.2\text{V}$, $R_{SET} = 511\Omega$	5.838350	5.898050	5.750950	A
45	Output Short-Circuit Current	$V_{OUT} = 0\text{V}$, $V_{IN} = 6.0\text{V}$, $R_{SET} = 5.11\text{k}$	1.317450	1.338450	1.361150	A
46	Output Short-Circuit Current	$V_{OUT} = 0\text{V}$, $V_{IN} = 6.0\text{V}$, $R_{SET} = 511\Omega$	6.375650	6.464150	6.539300	A
47	PSRR	$V_{P-P} = 300\text{mV}$, $f = 1\text{kHz}$, $I_{LOAD} = 3\text{A}$; $V_{IN} = 2.5\text{V}$, $V_{OUT} = 1.8\text{V}$	64.103100	67.373400	65.407000	dB
48	Enable Rising Threshold	$V_{IN} = 2.2\text{V}$	0.867700	0.835700	0.827700	V
49	Enable Rising Threshold	$V_{IN} = 6.0\text{V}$	0.915800	0.905800	0.893800	V
50	Enable Falling Threshold	$V_{IN} = 2.2\text{V}$	0.681400	0.671300	0.661300	V
51	Enable Falling Threshold	$V_{IN} = 6.0\text{V}$	0.727500	0.715400	0.707400	V
52	Enable Pin Leakage Current	$V_{IN} = 6.0\text{V}$, $EN = 0\text{V}$	-0.004900	-0.025200	-0.030100	μA
53	Enable Pin Leakage Current	$V_{IN} = 6.0\text{V}$, $EN = 6.0\text{V}$	-0.009750	-0.024850	-0.029650	μA
54	Enable Hysteresis	$V_{IN} = 2.2\text{V}$	184.368000	166.332000	168.336000	mV
55	Enable Hysteresis	$V_{IN} = 6.0\text{V}$	188.377000	190.381000	188.377000	mV
56	Enable Pin Propagation Delay	$V_{IN} = 2.2\text{V}$, EN rise to I_{OUT} rise	304.015700	299.771700	296.604250	μs
57	PG Rising Threshold	$V_{IN} = 2.2\text{V}$	88.455750	88.057850	88.741300	%
58	PG Rising Threshold	$V_{IN} = 6.0\text{V}$	89.994350	89.499600	90.142250	%
59	PG Falling Threshold	$V_{IN} = 2.2\text{V}$	85.755650	85.356800	85.996150	%
60	PG Falling Threshold	$V_{IN} = 6.0\text{V}$	86.812350	86.316300	86.870500	%
61	PG Hysteresis	$V_{IN} = 2.2\text{V}$	2.701500	2.699650	2.745150	%
62	PG Hysteresis	$V_{IN} = 6.0\text{V}$	3.182050	3.183350	3.271700	%
63	PG Low Voltage	$I_{SINK} = 1\text{mA}$	31.560800	31.295600	31.212750	mV
64	PG Low Voltage	$I_{SINK} = 6\text{mA}$	177.500500	177.572900	175.997050	mV
65	PG Leakage Current	$V_{IN} = 6.0\text{V}$, $PG = 6.0\text{V}$	0.017550	-0.000750	-0.002400	μA

NOTE:

14. See the [Radiation report](#).

ISL75051SEH, ISL75051SRH

Post Radiation Characteristics for High Dose and Low Dose $T_A = +25^\circ\text{C}$, unless otherwise noted. This data is typical test data post radiation exposure at a rate of 10mrad(Si)/s for low dose rate and 50-300rad(Si)/s for high dose rate. This data is intended to show typical parameter shifts due to High Dose Rate (HDR) or Low Dose Rate (LDR) radiation. These are not limits nor are they guaranteed. Low dose rate data applies only to ISL75051SEH.

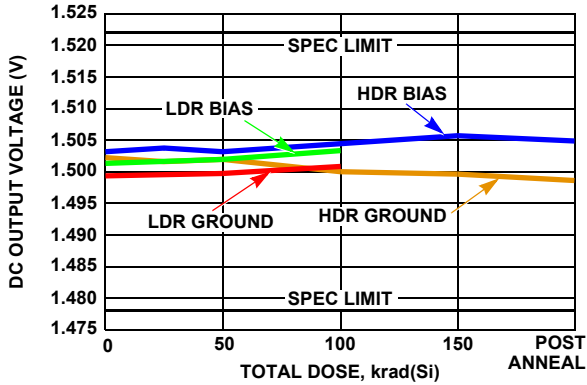

FIGURE 5. DC OUTPUT VOLTAGE, 1.5V_{OUT}, 3.6V_{IN} NO LOAD

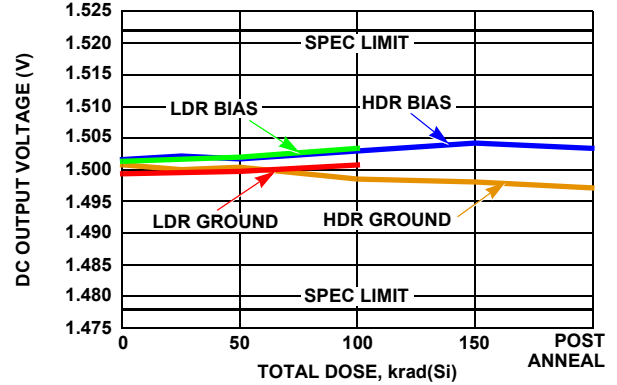

FIGURE 6. DC OUTPUT VOLTAGE, 1.5V_{OUT}, 3.6V_{IN}, 3A LOAD

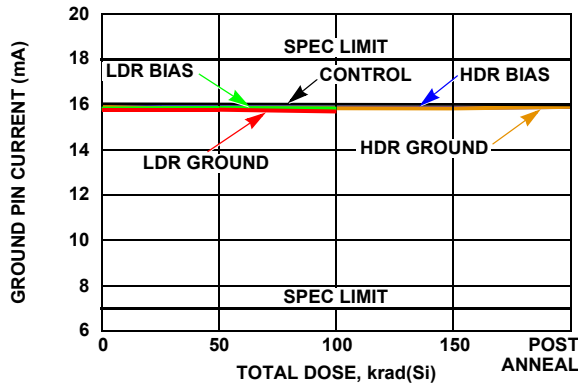

FIGURE 7. GROUND PIN CURRENT, 5.0V_{OUT}, 5.5V_{IN}, NO LOAD

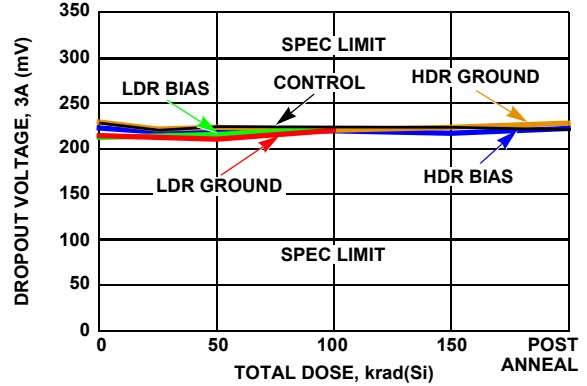

FIGURE 8. DROPOUT VOLTAGE, 2.5V_{OUT}, 3A LOAD CURRENT

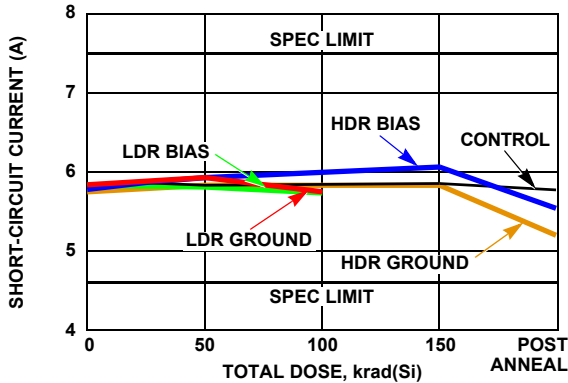

FIGURE 9. OUTPUT SHORT-CIRCUIT CURRENT, $R_{SET} = 511\Omega$, 2.2V_{IN}

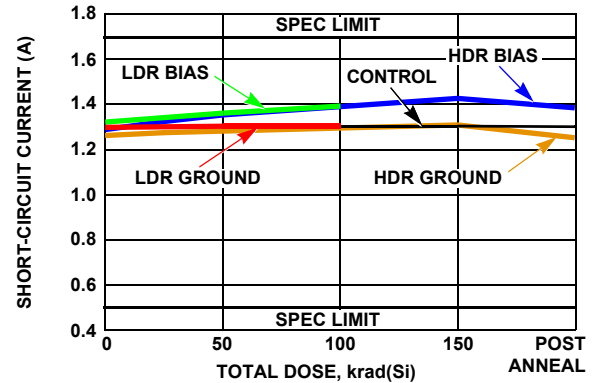

FIGURE 10. OUTPUT SHORT-CIRCUIT CURRENT, $R_{SET} = 5.11k\Omega$, 5.5V_{IN}

Typical Operating Performance

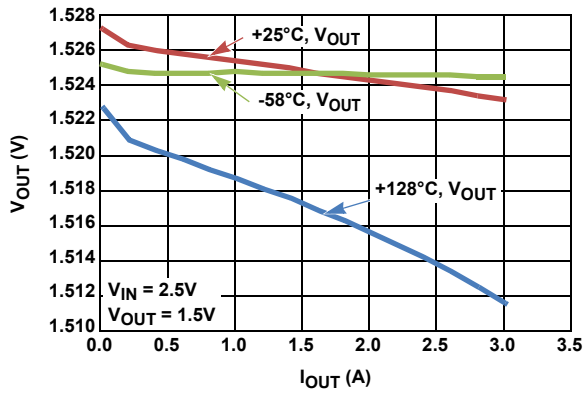

FIGURE 11. LOAD REGULATION, V_{OUT} vs I_{OUT}

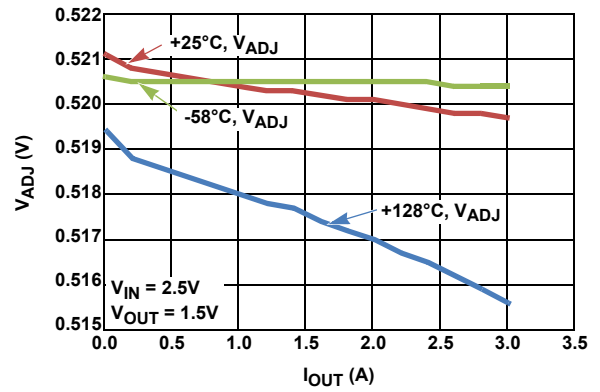

FIGURE 12. LOAD REGULATION, V_{ADJ} vs I_{OUT}

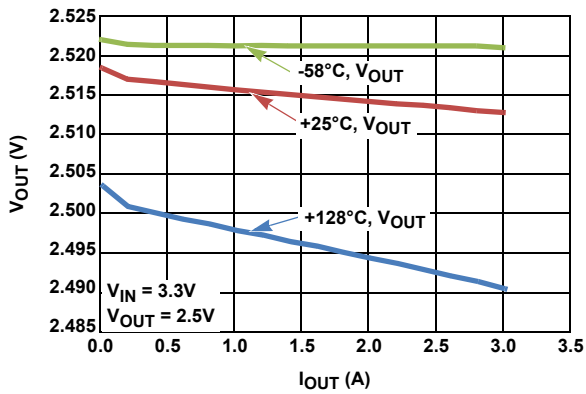

FIGURE 13. LOAD REGULATION, V_{OUT} vs I_{OUT}

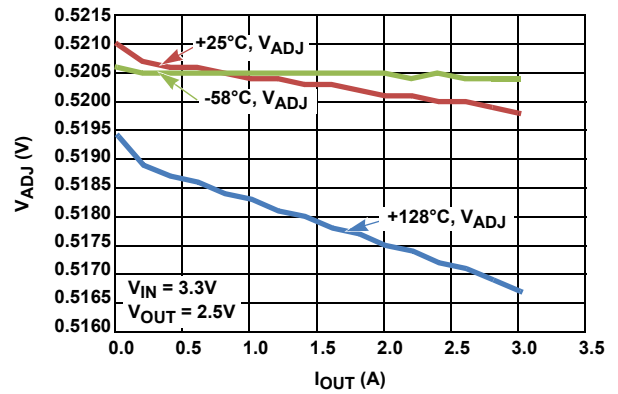

FIGURE 14. LOAD REGULATION, V_{ADJ} vs I_{OUT}

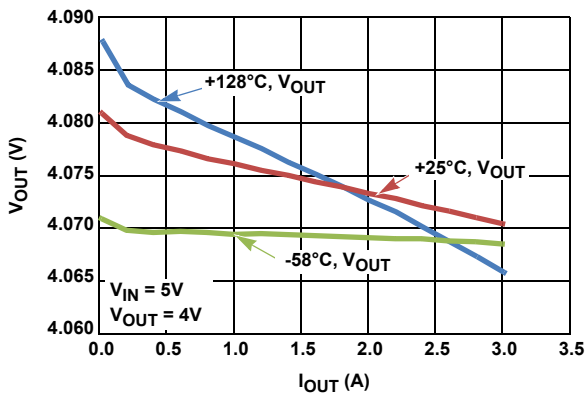

FIGURE 15. LOAD REGULATION, V_{OUT} vs I_{OUT}

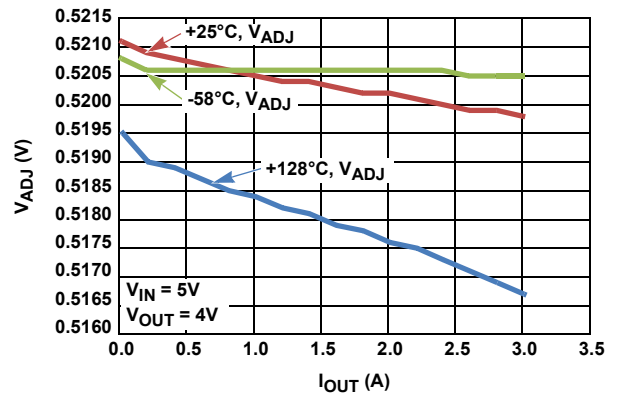

FIGURE 16. LOAD REGULATION, V_{ADJ} vs I_{OUT}

Typical Operating Performance (Continued)

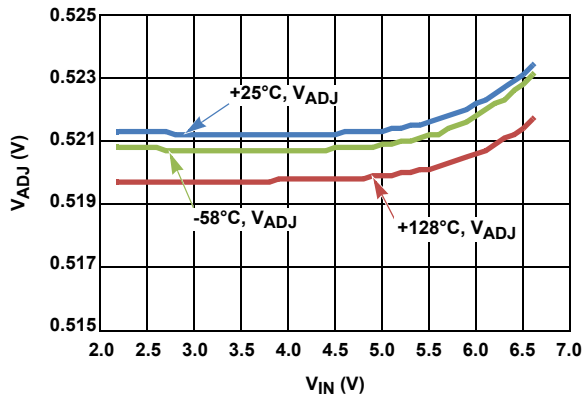

FIGURE 17. V_{IN} vs V_{ADJ} OVER-TEMPERATURE

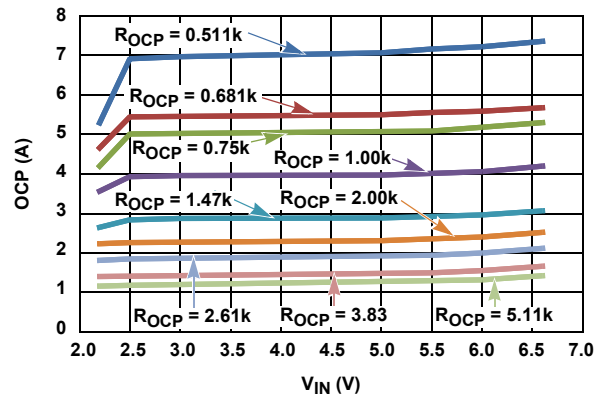

FIGURE 18. R_{OCP} vs OCP AT +25 °C, $V_{OUT} = 1.5V$

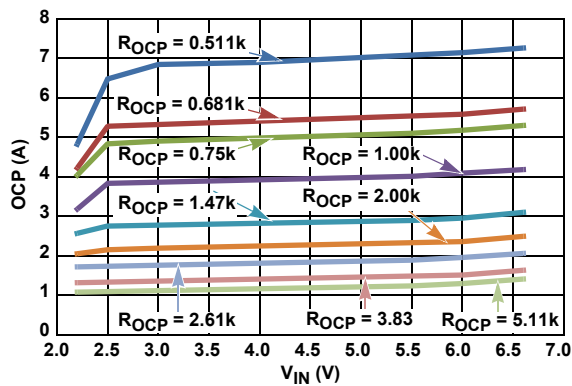

FIGURE 19. R_{OCP} vs OCP AT +128 °C, $V_{OUT} = 1.5V$

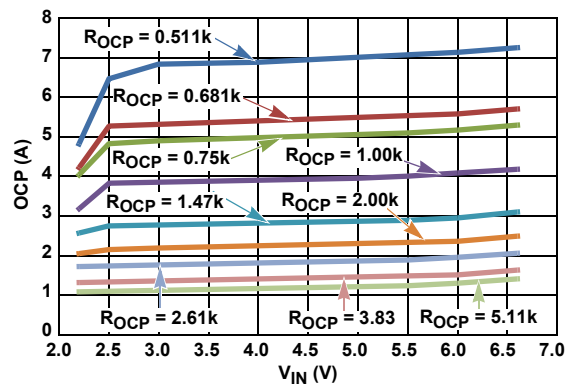

FIGURE 20. R_{OCP} vs OCP AT -58 °C, $V_{OUT} = 1.5V$

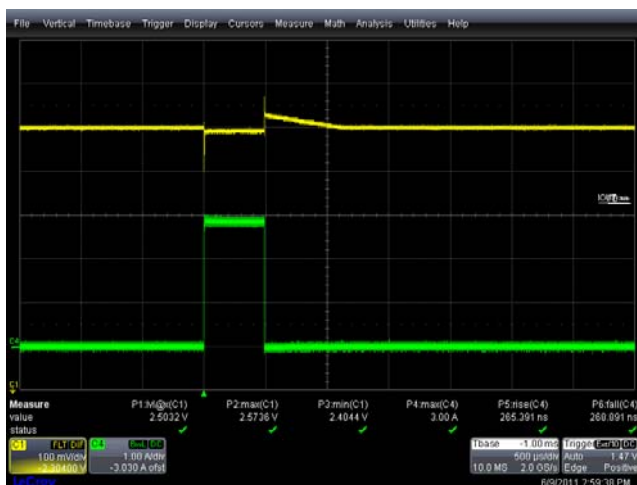

FIGURE 21. TRANSIENT LOAD RESPONSE, $V_{IN} = 3.3V$, $V_{OUT} = 2.5V$, $C_{OUT} = 47\mu F$, $35m\Omega$

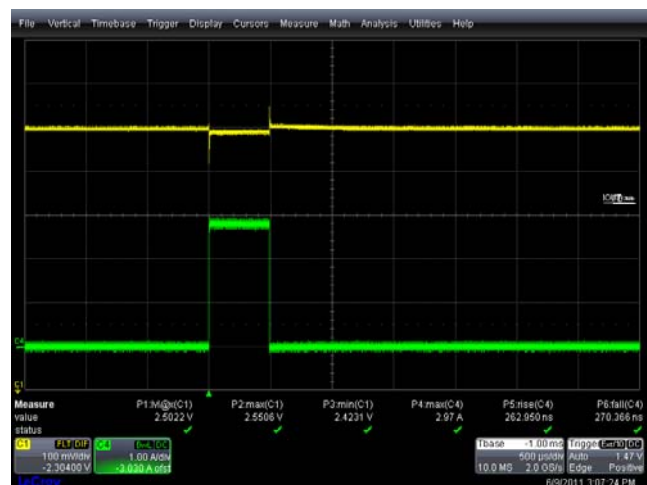

FIGURE 22. TRANSIENT LOAD RESPONSE, $V_{IN} = 3.3V$, $V_{OUT} = 2.5V$, $C_{OUT} = 220\mu F$, $25m\Omega$

Typical Operating Performance (Continued)



FIGURE 23. POWER-ON AND POWER-OFF, EN = 0 TO 1, +25 °C, VIN = 6V, VOUT = 0.8V, IOUT = 0.5A, PGOOD TURN-ON



FIGURE 24. POWER-ON AND POWER-OFF, EN = 0 TO 1, +25 °C, VIN = 2.2V, VOUT = 0.8V, IOUT = 0.5A, PGOOD TURN-ON



FIGURE 25. POWER-ON AND POWER-OFF, EN = 1 TO 0, +25 °C, VIN = 6V, VOUT = 0.8V, IOUT = 0.5A, PGOOD TURN-OFF



FIGURE 26. POWER-ON AND POWER-OFF, EN = 1 TO 0, +25 °C, VIN = 2.2V, VOUT = 0.8V, IOUT = 0.5A, PGOOD TURN-OFF

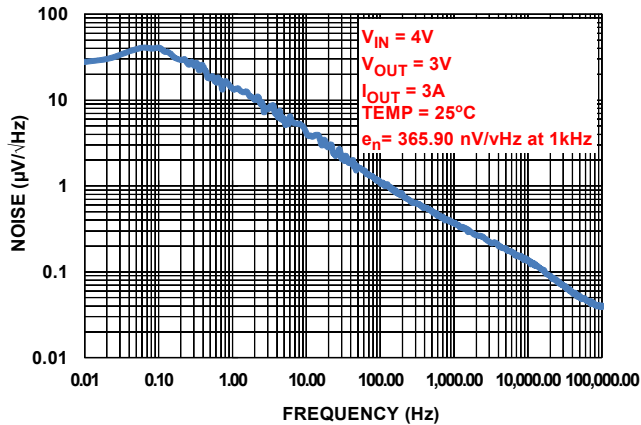

FIGURE 27. NOISE (µV/√Hz)

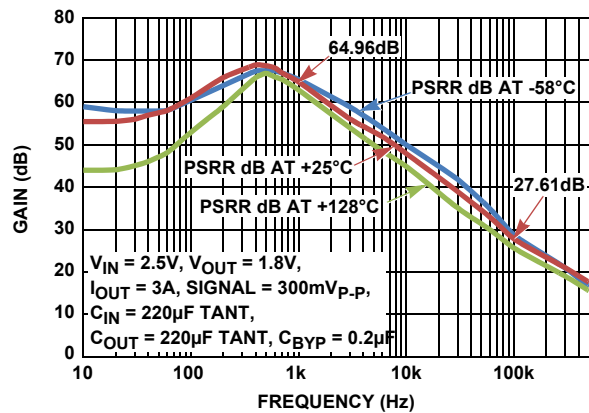

FIGURE 28. PSRR

Applications Information

Input Voltage Requirements

These radiation hardened LDOs will work from a V_{IN} in the range of 2.2V to 6.0V. The input supply can have a tolerance of as much as $\pm 10\%$ for conditions noted in the [“Electrical Specifications”](#). The minimum guaranteed input voltage is 2.2V. However, due to the nature of an LDO, V_{IN} must be some margin higher than the output voltage, and dropout at the maximum rated current of the application, if active filtering (PSRR) is expected from V_{IN} to V_{OUT} . The dropout spec of this family of LDOs has been generously specified to allow applications to design for efficient operation.

Adjustable Output Voltage

The output voltage of the radiation hardened LDOs can be set to any user-programmable level between 0.8V to 5.0V. This is achieved with a resistor divider connected between the OUT, ADJ and GND pins. With the internal reference at 0.52V, the divider ratio should be fixed such that when the desired V_{OUT} level is reached, the voltage presented to the ADJ pin is 0.52V. Resistor values for typical voltages are shown in [Table 1](#).

TABLE 1. RESISTOR VALUES FOR TYPICAL VOLTAGES

V_{OUT} (V)	R_{BOTTOM}	R_{TOP} (K)
0.8	7.87k	4.32
1.5	2.26k	4.32
1.8	1.74k	4.32
2.5	1.13k	4.32
4.0	634	4.32
5.0	499	4.32

$$R_{BOTTOM} = \frac{R_{TOP}}{\left(\frac{V_{OUT}}{V_{ADJ}}\right) - 1} \quad (EQ. 1)$$

Input and Output Capacitor Selection

The radiation hardened operation requires the use of a combination of tantalum and ceramic capacitors to achieve a good volume-to-capacitance ratio. The recommended combination is a 220 μ F, 10V, 25m Ω rated DSSC 04051-032 series tantalum capacitor in parallel with a 0.1 μ F MIL-PRF-49470 CDR04 ceramic capacitor that is connected between V_{IN} to GND pins and V_{OUT} to GND pins of the LDO, with PCB traces no longer than 0.5cm.

The stability of the device depends on the capacitance and ESR of the output capacitor. The usable ESR range for the device is 6m Ω to 100m Ω . At the lower limit of ESR = 6m Ω , the phase margin is about 51°. On the high-side, an ESR of 100m Ω is found to limit the gain margin at around 10dB. The typical GM/PM seen with capacitors are shown in [Table 2](#).

TABLE 2. TYPICAL GM/PM WITH VARIOUS CAPACITORS

CAPACITANCE (μ F)	ESR (m Ω)	GAIN MARGIN (dB)	PHASE MARGIN (°)
47	35	14	55
100	25	16	57
220	6	19	51
220	25	16	69
100	100	10	62

Type numbers of KEMET capacitors used in the device are shown in [Table 3](#).

TABLE 3. KEMET CAPACITORS USED IN DEVICE

KEMET TYPE NUMBER	CAPACITOR DETAILS
T525D476M016ATE035	47 μ F, 10V, 35m Ω
T525D107M010ATE025	100 μ F, 10V, 25m Ω
T530D227M010ATE006	220 μ F, 10V, 6m Ω
T525D227M010ATE025	220 μ F, 10V, 25m Ω
T495X107K016ATE100	100 μ F, 16V, 100m Ω

A typical gain phase plot measured on the ISL75051SRHEVAL1Z evaluation board for $V_{IN} = 3.3V$, $V_{OUT} = 1.8V$ and $I_{OUT} = 3A$ with a 220 μ F, 10V, 25m Ω capacitor is shown in [Figure 29](#) and is measured at GM = 16.3dB and PM = 69.16°.

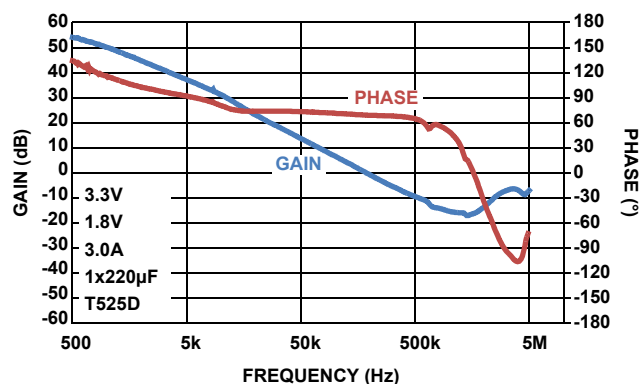

FIGURE 29. TYPICAL GAIN PHASE PLOT

Enable

These devices can be enabled by applying a logic high on the EN pin. The enable threshold is typically 0.9V. A soft-start cycle is initiated when the devices are enabled using this pin. Taking this pin to logic low disables the devices.

The EN can be driven from either an open drain or a totem pole logic drive between EN pin and GND. Assuming an open-drain configuration, M1 will actively pull-down the EN line, as shown in [Figure 30 on page 16](#), and thereby discharge the input capacitance, shutting off the devices immediately.

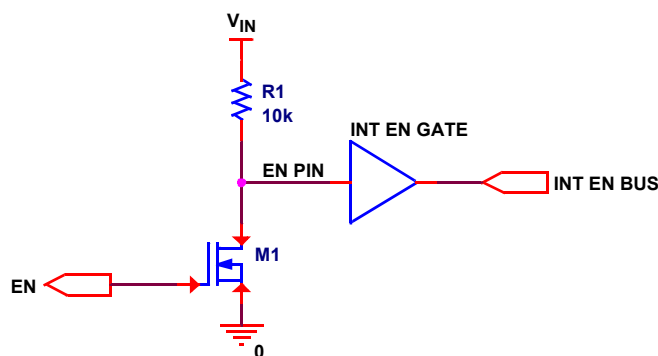

FIGURE 30. ENABLE

Power-Good

The power-good pin is asserted high when the voltage on the ADJ pin crosses the rising threshold of $0.9 \times V_{ADJ}$ (typical). On the falling threshold, power-good is asserted low when the voltage on the ADJ pin crosses the falling threshold of $0.88 \times V_{ADJ}$. The power-good output is an open-drain output rated for a continuous sink current of 1mA.

Soft-Start

Soft-start is achieved by means of the BYP pin charging time constant. The capacitor value on the pin determines the time constant and can be calculated using [Equations 2](#) through [4](#) based on V_{IN} range:

If V_{IN} range is $2.2V \leq V_{IN} < 2.7V$:

$$t_{SS} = (-4.8376 \cdot V_{IN}) + (0.0254 \cdot T_A) + (0.0522 \cdot C_{BYP}) + 11.8526 \quad (\text{EQ. 2})$$

If V_{IN} range is $2.7V \leq V_{IN} < 4.0V$:

$$t_{SS} = (-1.4711 \cdot V_{IN}) + (0.0179 \cdot T_A) + (0.0377 \cdot C_{BYP}) + 4.7430 \quad (\text{EQ. 3})$$

If V_{IN} range is $4.0V \leq V_{IN} < 6.0V$:

$$t_{SS} = (-0.4458 \cdot V_{IN}) + (0.0130 \cdot T_A) + (0.0295 \cdot C_{BYP}) + 1.8527 \quad (\text{EQ. 4})$$

Where t_{SS} = soft-start time (ms), V_{IN} = Input supply (V), T_A = Ambient Temperature and C_{BYP} = BYPASS capacitor (nF).

The BYPASS capacitor, C_1 , charges with a current source and provides an EA reference, -IN, with an SS ramp. V_{OUT} , in turn, follows this ramp. The ramp rate can be calculated based on the C_1 value. For conditions in which C_1 is opened, or for small values of C_1 , the ramp is provided by $C_2 = 50\text{pF}$, with a source of $0.5\mu\text{A}$. Connecting $C_1 \text{ min} = 0.1\mu\text{F}$ to the BYPASS pin is recommended for normal operation.

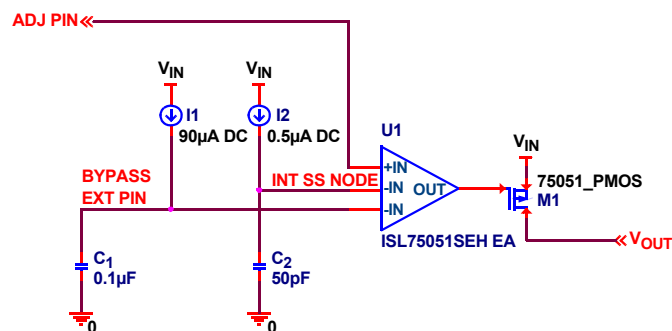

FIGURE 31. SOFT-START

Current Limit Protection

The radiation hardened LDOs incorporate protection against overcurrent due to any short or overload condition applied to the output pin. The current limit circuit becomes a constant current source when the output current exceeds the current limit threshold, which can be adjusted by means of a resistor connected between the OCP pin and GND. If the short or overload condition is removed from V_{OUT} , then the output returns to normal voltage mode regulation. The OCP can be calculated with [Equation 5](#):

$$2.2V \leq V_{IN} < 3.0V: \quad (\text{EQ. 5})$$

$$I_{OCP} = (V_{IN} \cdot 1.2688) + \left(\frac{2.8691}{R_{OCP}}\right) + (T_A \cdot -0.002) - 2.1851$$

$$3.0V \leq V_{IN} < 6.6V:$$

$$I_{OCP} = (V_{IN} \cdot 6.168E - 02) + \left(\frac{3.3161}{R_{OCP}}\right) + (T_A \cdot 1.5312E - 04) - 0.3176$$

Where OCP = Overcurrent Threshold in amps, and R_{OCP} = OCP resistor in k Ω .

In the event of an overload condition based on the set OCP limit, the die temperature may exceed the internal over-temperature limit, and the LDOs begin to cycle on and off due to the fault condition ([Figure 32](#)). However, thermal cycling may never occur if the heatsink used for the package can keep the die temperature below the limits specified for thermal shutdown.

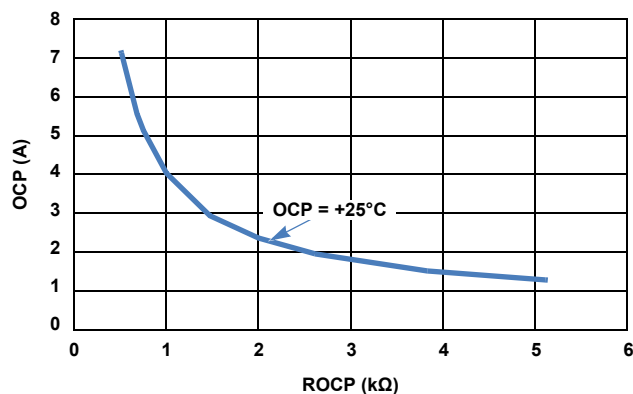

FIGURE 32. OCP vs ROCP

Thermal Guidelines

If the die temperature exceeds approximately +175°C, then the LDO output shuts down to zero until the die temperature cools to approximately +155°C. The level of power combined with the thermal impedance of the package (θ_{JC} of 4°C/W for the 18 Ld CDFP package) determines whether the junction temperature exceeds the thermal shutdown temperature specified in the [“Electrical Specifications”](#) table on page 6.

These devices should be mounted on a high effective thermal conductivity PCB with thermal vias, per JESD51-7 and JESD51-5. Place a silpad between package base and PCB copper plane. The V_{IN} and V_{OUT} ratios should be selected to ensure that dissipation for the selected V_{IN} range keeps T_J within the recommended operating level of +150°C for normal operation.

Weight Characteristics

Weight of Packaged Device

K18.D: 1.07 Grams typical with leads clipped

K18.E: 1.07 Grams typical with leads clipped

Die Characteristics

Die Dimensions

4555µm x 4555µm (179.3 mils x 179.3 mils)

Thickness: 304.8µm ± 25.4µm (12.0 mils ± 1 mil)

Interface Materials

GLASSIVATION

Type: Silicon Oxide and Silicon Nitride

Thickness: 0.3µm ± 0.03µm to 1.2µm ± 0.12µm

TOP METALLIZATION

Type: AlCu (99.5%/0.5%)

Thickness: 2.7µm ± 0.4µm

BACKSIDE METALLIZATION

None

SUBSTRATE

Type: Silicon

BACKSIDE FINISH

Silicon

PROCESS

0.6µM BiCMOS Junction Isolated

ASSEMBLY RELATED INFORMATION

Substrate Potential

Unbiased

ADDITIONAL INFORMATION

Worst Case Current Density

< 2 x 10⁵ A/cm²

Transistor Count

2932

Layout Characteristics

Step and Repeat

4555µm x 4555µm

Metallization Mask Layout

PAD X Y COORDINATES			
PAD	NAME	X (μm)	Y (μm)
1	GND	0	0
2	GND	-393	0
3	VOUT	-711	-710
4	VOUT	-711	-1858
5	VOUT	-711	-2964
6	ADJ	-1680	-3070
7	BYP	-1621	-3879
8	EN	2164	-3879
9	OCP	2222	-3131
10	VIN	1078	-2965
11	VIN	1078	-1853
12	VIN	1078	-711
13	PG	420	-25

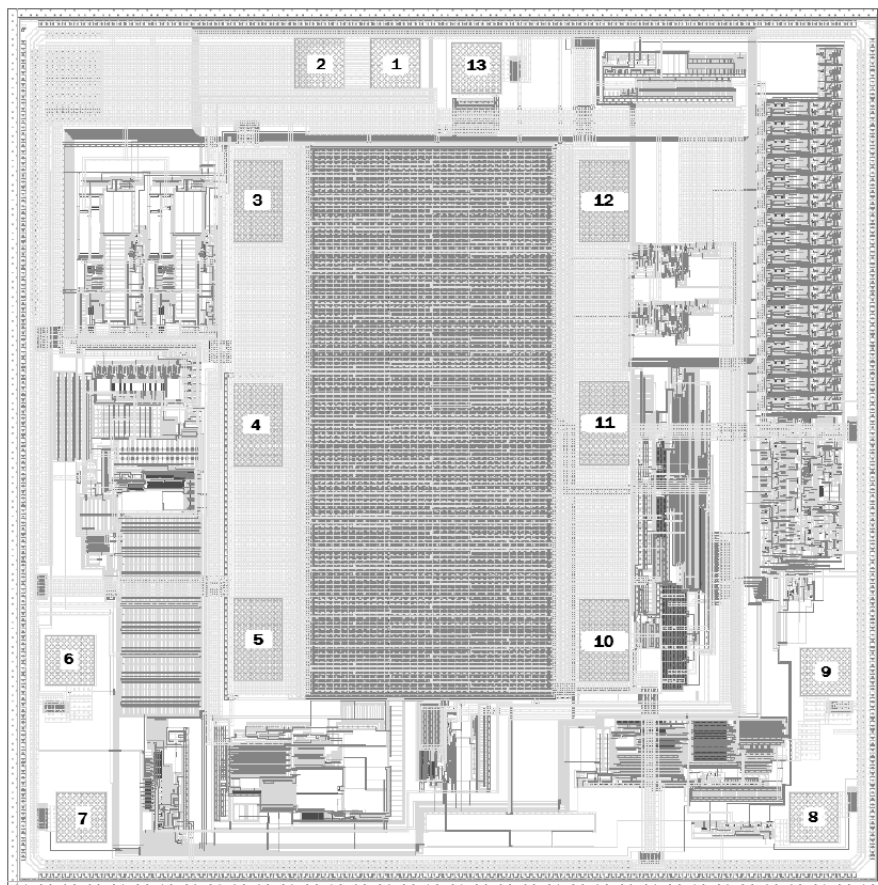

For additional products, see www.intersil.com/en/products.html

Intersil products are manufactured, assembled and tested utilizing ISO9001 quality systems as noted in the quality certifications found at www.intersil.com/en/support/qualandreliability.html

Intersil products are sold by description only. Intersil Corporation reserves the right to make changes in circuit design, software and/or specifications at any time without notice. Accordingly, the reader is cautioned to verify that data sheets are current before placing orders. Information furnished by Intersil is believed to be accurate and reliable. However, no responsibility is assumed by Intersil or its subsidiaries for its use; nor for any infringements of patents or other rights of third parties which may result from its use. No license is granted by implication or otherwise under any patent or patent rights of Intersil or its subsidiaries.

For information regarding Intersil Corporation and its products, see www.intersil.com

ISL75051SEH, ISL75051SRH

Revision History The revision history provided is for informational purposes only and is believed to be accurate, but, not warranted. Please go to web to make sure you have the latest revision.

DATE	REVISION	CHANGE
September 23, 2016	FN8294.6	Added ISL75051SRH information throughout document. Updated Features list, Related Literature section, and description on page 1. Replaced Figure 27 on page 14. Replaced Equation 5 on page 16.
December 15, 2014	FN8294.5	Made correction to Charged Device Model testing information from Tested per CDM-22C10ID to JESD22-C101D Added Related Literature section on page 1. Added ESD ratings under the Abs Max section on page 5. Human Body Model (Tested per MIL-PRF-883 3015.7) 2.5kV Machine Model (Tested per JESD22-A115-A) 250V Charged Device Model (Tested per CDM-22C10ID).....1kV
September 15, 2014	FN8294.4	Replaced Equation 2 and added Equations 3 and 4 on page 16. Removed second line of Yaxis title for Figures 5, 6, 7, 7 and 8 as it was redudant information that was already in the Figure titles.
March 28, 2014	FN8294.3	Thermal Information, page 5: Updated θ_{JC} (°C/W) for the 18 Ld CDFP Package with Bottom Metal and Solder Mount from "4" to "3.3". Removed both "Enable Pin Turn-on Delay" rows from "Electrical Specifications" on page 6. Added EQ1 to page 15.
February 11, 2014	FN8294.2	Soft-Start section, page 16: 1) EQ1 Changed From: Trise (ms)=0.00577xCss (nF) To: Trise (ms)=0.0326xCss (nF) 2) Changed From: "a 90µA source current " To: " a current source"
September 12, 2013	FN8294.1	Updated Equation 2 on page 16. Weight Characteristics on page 17: Added K18.E: 1.07 Grams typical with leads clipped. Updated Equation 2 on page 16. Added a note to the pin configuration figure on page 3. Ordering information table on page 4: Added part number ISL75051SRHX/SAMPLE. Updated Equation 2 on page 16. Added part numbers ISL75051SEHVFE and ISL75051SEHFE/PROTO (18 Ld CDFP with bottom metal) to ordering information table on page 4. Added 18 Ld CDFP Package theta ja= 28 and theta jc = 4 to thermal information table on page 5. Updated POD for k18.D from Rev3 to Rev5: Added bottom of lead to bottom of package. Added POD k18.E: 18 Ld ceramic metal seal flatpack package with bottom metal.
August 28, 2012	FN8294.0	Initial Release.

About Intersil

Intersil Corporation is a leading provider of innovative power management and precision analog solutions. The company's products address some of the largest markets within the industrial and infrastructure, mobile computing and high-end consumer markets.

For the most updated datasheet, application notes, related documentation and related parts, please see the respective product information page found at www.intersil.com.

You may report errors or suggestions for improving this datasheet by visiting www.intersil.com/ask.

Reliability reports are also available from our website at www.intersil.com/support.

Package Outline Drawing

For the most recent package outline drawing, see [K18.D](#).

K18.D

18 LEAD CERAMIC METAL SEAL FLATPACK PACKAGE

Rev 5, 3/13

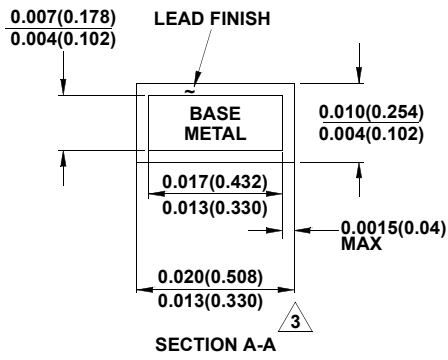
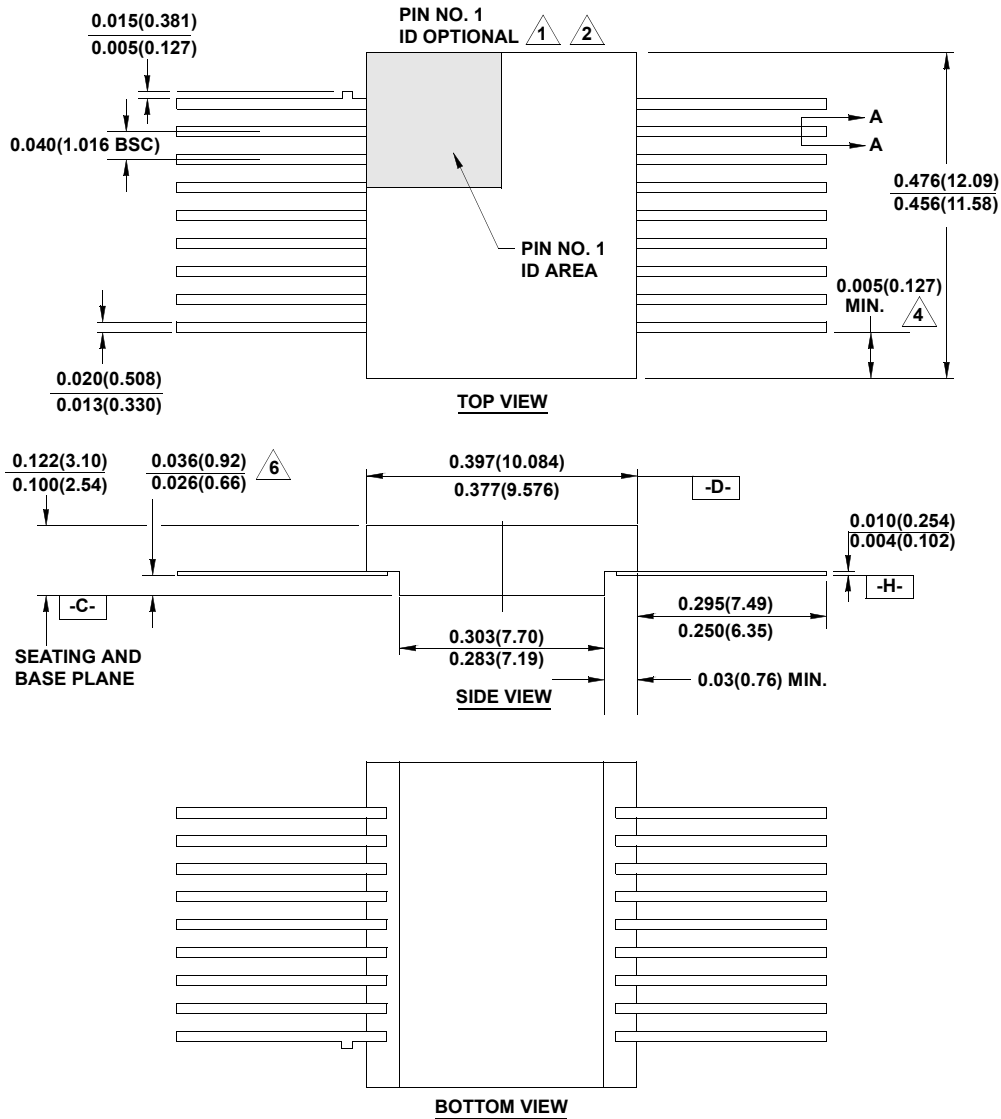

NOTES:

1. Index area: A notch or a pin one identification mark shall be located adjacent to pin one and shall be located within the shaded area shown. The manufacturer's identification shall not be used as a pin one identification mark. Alternately, a tab may be used to identify pin one.
2. If a pin one identification mark is used in addition to a tab, the limits of the tab dimension do not apply.
3. The maximum limits of lead dimensions (section A-A) shall be measured at the centroid of the finished lead surfaces, when solder dip or tin plate lead finish is applied.
4. Measure dimension at all four corners.
5. For bottom-brazed lead packages, no organic or polymeric materials shall be molded to the bottom of the package to cover the leads.
6. Dimension shall be measured at the point of exit (beyond the meniscus) of the lead from the body. Dimension minimum shall be reduced by 0.0015 inch (0.038mm) maximum when solder dip lead finish is applied.
7. Dimensioning and tolerancing per ANSI Y14.5M - 1982.
8. Dimensions = INCH (mm). Controlling dimension: INCH.

Package Outline Drawing

For the most recent package outline drawing, see [K18.E](#).

K18.E

18 LEAD CERAMIC METAL SEAL FLATPACK PACKAGE WITH BOTTOM METAL

Rev 1, 3/13

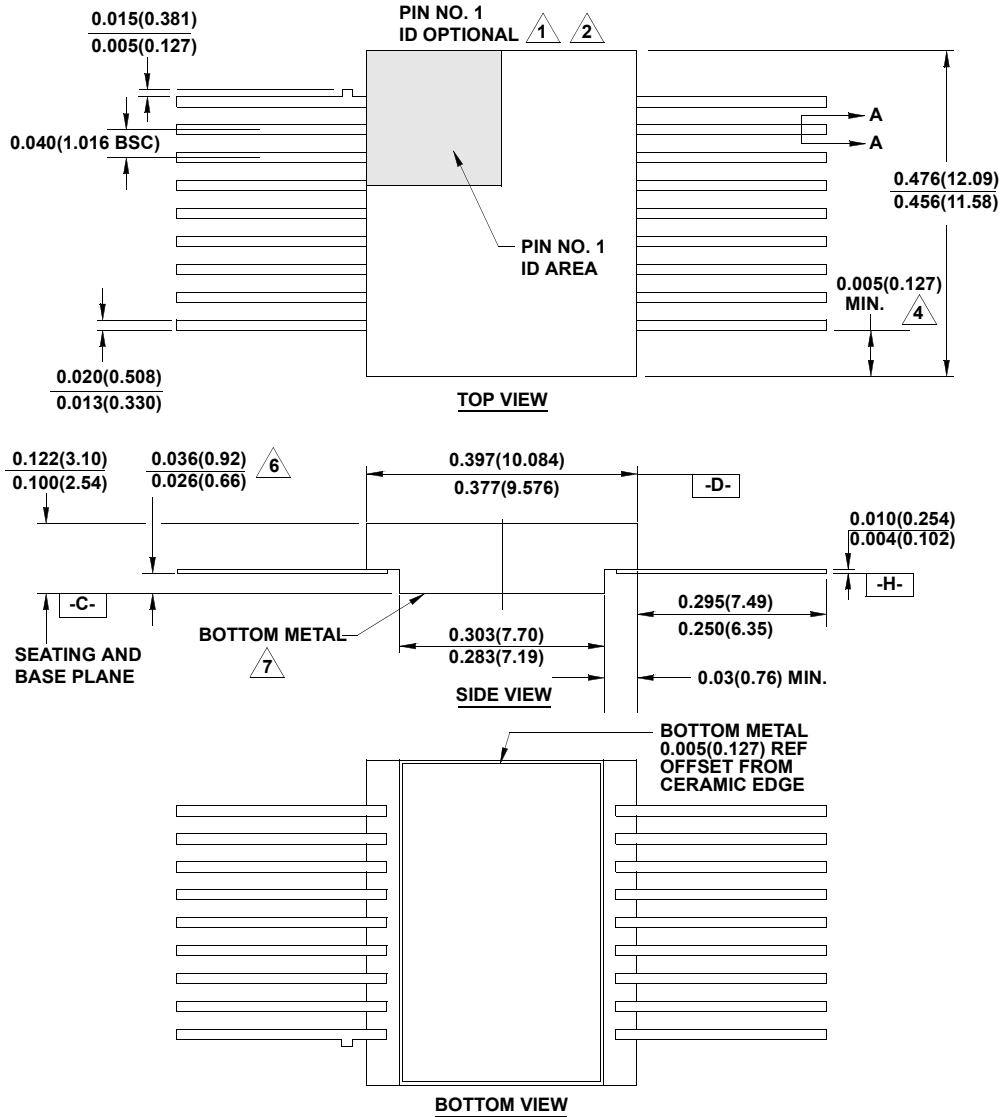

NOTES:

1. Index area: A notch or a pin one identification mark shall be located adjacent to pin one and shall be located within the shaded area shown. The manufacturer's identification shall not be used as a pin one identification mark. Alternately, a tab may be used to identify pin one.
2. If a pin one identification mark is used in addition to a tab, the limits of the tab dimension do not apply.
3. The maximum limits of lead dimensions (section A-A) shall be measured at the centroid of the finished lead surfaces, when solder dip or tin plate lead finish is applied.
4. Measure dimension at all four corners.
5. For bottom-brazed lead packages, no organic or polymeric materials shall be molded to the bottom of the package to cover the leads.
6. Dimension shall be measured at the point of exit (beyond the meniscus) of the lead from the body. Dimension minimum shall be reduced by 0.0015 inch (0.038mm) maximum when solder dip lead finish is applied.
7. The bottom of the package is a solderable metal surface.
8. Dimensioning and tolerancing per ANSI Y14.5M - 1982.
9. Dimensions = INCH (mm). Controlling dimension: INCH.

