

REVISIONS					
#	DATE	DESCRIPTION	BY	CHK	APP'D
E	23APR2013	LOGO CHANGE	JC	KZ	

MECHANICAL:

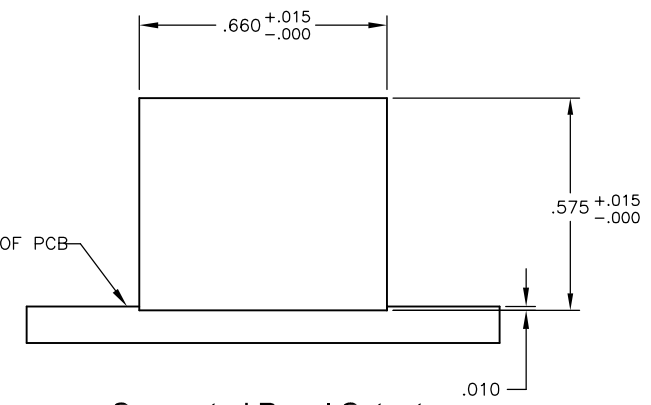

4G01 GIGABIT MAGNETIC CIRCUIT

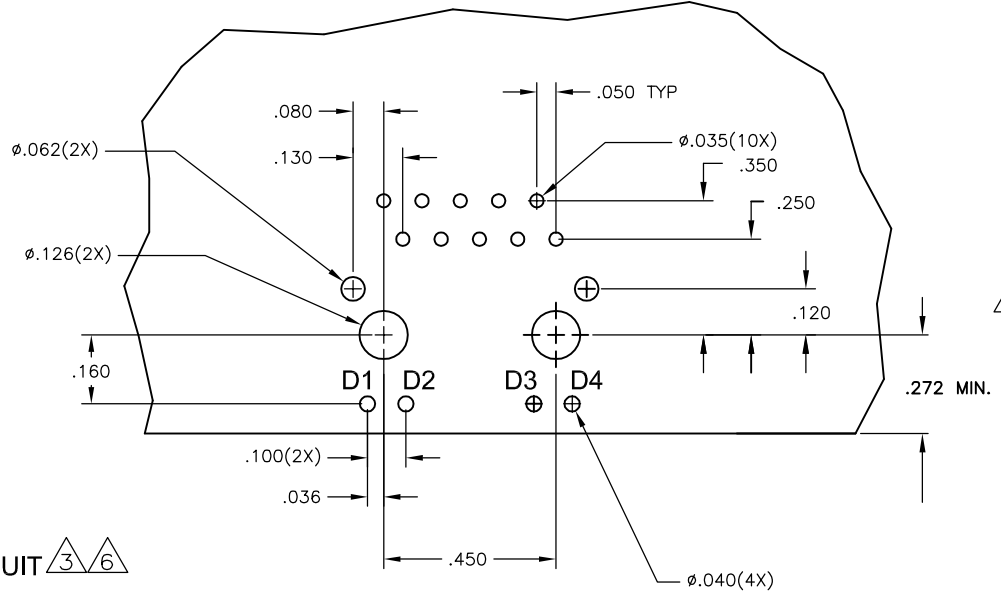
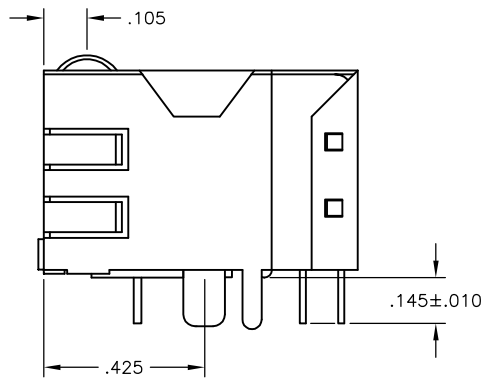
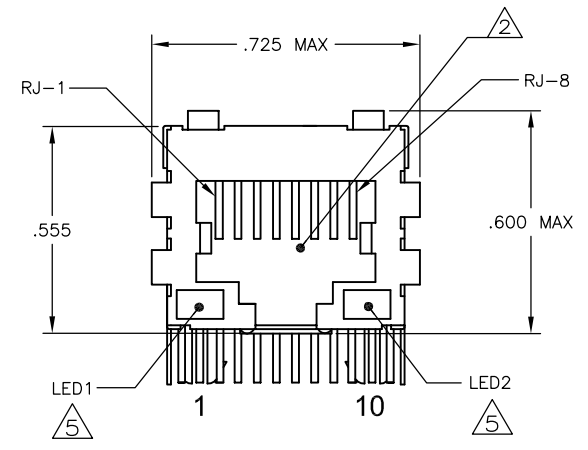
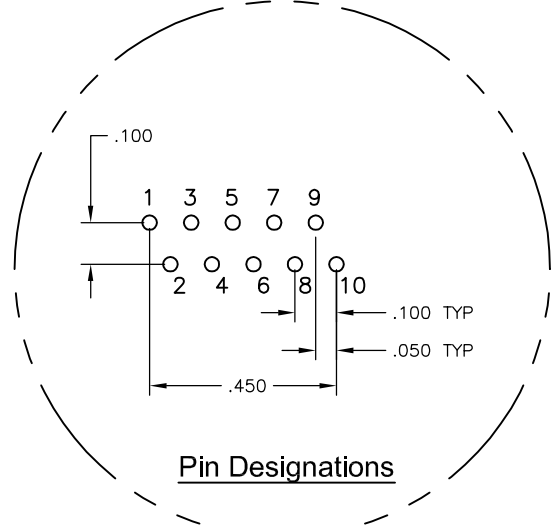
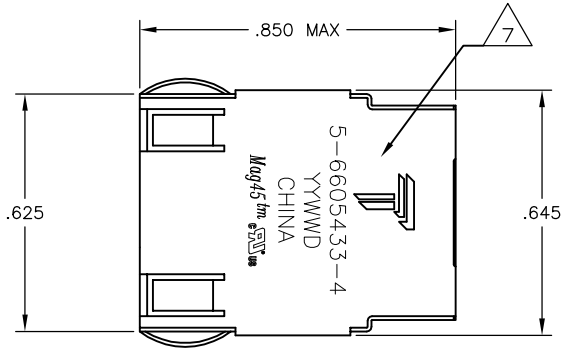
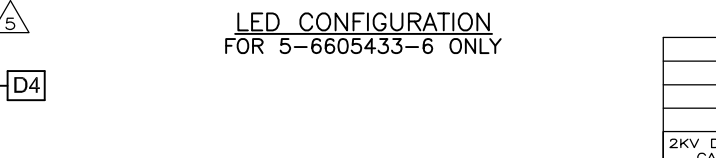
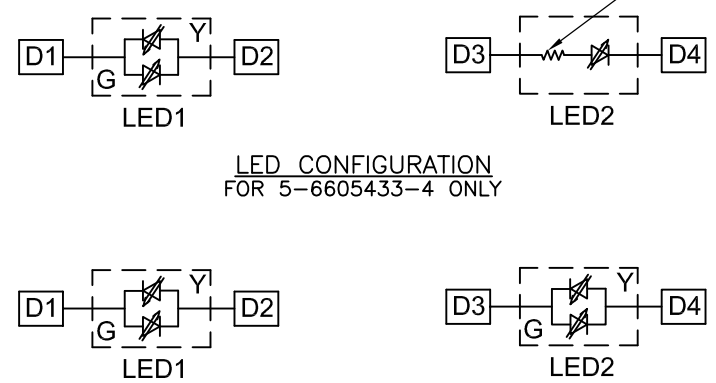
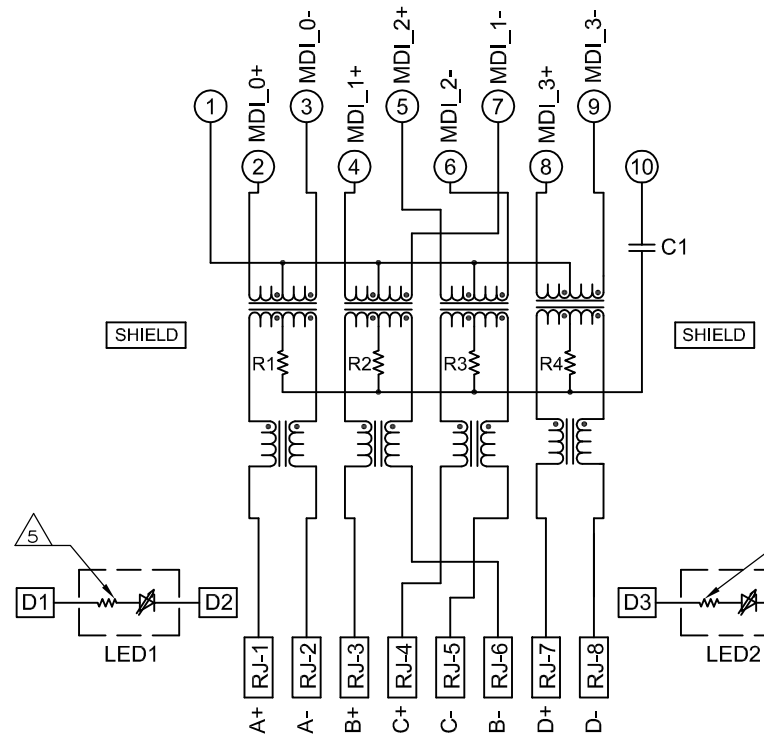

MATERIALS:
 HOUSING - THERMOPLASTIC PET POLYESTER FLAMMABILITY RATING UL 94V-0.
 SHIELD - .010" THICK, C26800 BRASS PREPLATED WITH 30μINCH SEMI-BRIGHT NICKEL. SOLDER TABS POST DIPPED WITH 100μINCH MIN SAC SOLDER.
 MOD JACK CONTACTS - 0.0157 X 0.018" PHOSPHOR BRONZE, 50μINCH MIN OVERALL NICKEL UNDERPLATE, WITH SELECT 50μINCH MIN HARD GOLD FINISH PLATE SOLDER TAILS WITH 100μINCH MIN MATTE TIN AND/OR SAC SOLDER DIP.
 LIGHT EMITTING DIODE(LED) - DIFFUSED EPOXY LENS, .020" x .020" CARBON STEEL WIREFRAME LEADS PRE-PLATED WITH 80μINCH SILVER OVER 40μINCH NICKEL UNDERPLATE OVER 40μINCH COPPER UNDERPLATE. POST-PLATED WITH 100μINCH MIN MATTE TIN AND/OR SAC SOLDER DIP OR PURE TIN SOLDER DIP.

RJ45 JACK CAVITY CONFORMS TO FCC RULES AND REGULATIONS PART 68, SUB PART F.

MAGNETICS
 -IMPEDANCE: 100 OHMS
 -TURNS RATIO (CHIP: CABLE): 1:1 ALL FOUR PAIRS
 -OPEN CIRCUIT INDUCTANCE (OCL): 350μH MIN @100kHz, 0.1VRMS, 8mADC BIAS FROM 0°C TO 70°C, ALL FOUR PAIRS
 -ALL FOUR PAIRS BI-DIRECTIONAL
 -PERFORMANCE @ 25°C:
 INSERTION LOSS (IL): 1.1dB MAX FROM 0.5MHz TO 100MHz
 RETURN LOSS (RL): 18dB MIN FROM 0.5MHz TO 40MHz
 12-20LOG(f/80)dB MIN FROM 40.1MHz TO 100MHz
 CROSSTALK ATTENUATION: 35dB MIN FROM 0.5MHz TO 40MHz
 33-20LOG(f/50)dB MIN FROM 40.1MHz TO 100MHz
 COMMON MODE REJECTION RATIO (CMRR): 30dB MIN FROM 0.5MHz TO 100MHz
 -ISOLATION VOLTAGE: 2250VDC (MAX) FOR 60 SECONDS WITH A RISE TIME OF 500V/SEC.

OPERATING TEMPERATURE: FROM 0°C TO +70°C

THE 250 OHM LED RESISTORS ARE OPTIONAL, PLEASE SEE CHART FOR PRESENCE OR ABSENCE OF LED RESISTORS. IF THE LED WITHOUT 250 OHM RESISTORS, LED IS DRIVEN WITH CONSTANT CURRENT AT APPROX 20mA.
 LED COLOR: DOMINANT WAVELENGTH (λD): GREEN 568 nm TYP @ IF=20mA
 FORWARD VOLTAGE (VF): GREEN 2.2V TYP @ IF=20mA
 DOMINANT WAVELENGTH (λD): YELLOW 588 nm TYP @ IF=20mA
 FORWARD VOLTAGE (VF): YELLOW 2.1V TYP @ IF=20mA.
 IF THE LED WITH 250 OHM RESISTORS, LED IS DRIVEN WITH 5V VOLTAGE AND THE MAX OPERATING CURRENT IS 20mA.
 LED COLOR : DOMINANT WAVELENGTH (λD): GREEN 568 nm TYP @ VF=5V
 FORWARD CURRENT (IF): GREEN 12 mA TYP @ VF=5V
 DOMINANT WAVELENGTH (λD): YELLOW 588 nm TYP @ VF=5V
 FORWARD CURRENT (IF): YELLOW 13 mA TYP @ VF=5V

THE MAGNETICS ARE SYMMETRIC, AND SUPPORT AUTO-MDI/MDIX.

TRP CONNECTOR LOGO, TE CONNECTIVITY PART NUMBER, DATE CODE, COUNTRY OF ORIGIN AND AGENCY APPROVAL MARKING IN APPROXIMATE LOCATION SHOWN.

THESE PARTS ARE RECOMMENDED FOR WAVE SOLDERING PROCESS, PREHEAT TEMPERATURE IS 120°C TO 160°C, 120 SECONDS TO 180 SECONDS, PEAK SOLDERING TEMPERATURE IS 260 °C MAX, 10 SECONDS MAX.

YES	GREEN	YES	GREEN	YES	6-6605433-1
YES	GREEN	NO	YELLOW	NO	5-6605433-8
YES	GREEN/YELLOW	NO	GREEN/YELLOW	NO	5-6605433-6
YES	GREEN/YELLOW	NO	GREEN	YES	5-6605433-4

THIS DRAWING IS A CONTROLLED DOCUMENT.		DWG: G. ATTADIA - 09MAR2005 CHK: D. FAROLE - 09MAR2005 APP'D: D. FAROLE - 09MAR2005		TRP connector Dongguan China	
DIMENSIONS: INCHES 0 PLC ± - 1 PLC ± .010 2 PLC ± .005 3 PLC ± .005 4 PLC ± .005 ANGLES ± -		TOLERANCES UNLESS OTHERWISE SPECIFIED: PRODUCT SPEC: 108-2100 APPLICATION SPEC:		PART NUMBER: C-6605433	
MATERIAL: A1		WEIGHT: -		RESTRICTED TO: -	
CUSTOMER DRAWING		SCALE: NTS		SHEET 1 OF 1 REV E	

C1=1000pF, 2kV DECOUPLING CAPACITOR
 R1-R4 = 75 OHMS, 1/16 W RESISTORS