

RECOMMENDED PCB LAYOUT COMPONENT VIEW

MATERIAL:
 HOUSING MATERIAL: LCP
 FLAMABILITY RATING: UL94-V0
 COLOR: IVORY
 ACTUATOR MATERIAL: LCP
 COLOR: BLACK
 CONTACT MATERIAL: PHOSPOR BRONZE
 CONTACT PLATING: 100µ TIN OVER 50µ NI
 QUALITY CLASS: 25 MATING CYCLES*

ENVIRONMENTAL:
 OPERATING TEMPERATURE: -25°C UP TO 85°C
 COMPLIANCE: LEAD FREE AND ROHS

ELECTRICAL:
 CURRENT RATING: 1.0A
 WORKING VOLTAGE: 125V
 INSULATION RESISTANCE: >100MOHM
 DIELECTRIC WITHSTANDING VOLT.: 500VAC/MN
 CONTACT RESISTANCE: 20mOHM MAX

STANDARD
 CERTIFIED: E323964 / MODEL NUMBER 686
 FOLLOWED BY 1 OR 3, FOLLOWED BY 04 THRU 28,
 FOLLOWED BY 1244, FOLLOWED BY NUMERIC DIGITS

SOLDERING:
 REFLOW PROCESS ONLY

PACKAGING
 TAPE & REEL WITH CAP

DIMENSION:
 A = B + 7.0MM
 B = 1.0MM x (NB PINS - 1)
 C = B + 2.00MM
 D = B + 5.85MM

PINS	DIM H	DIM I
4~14P	1.50	4.70
15~19P	1.60	4.80
20~29P	1.70	4.90

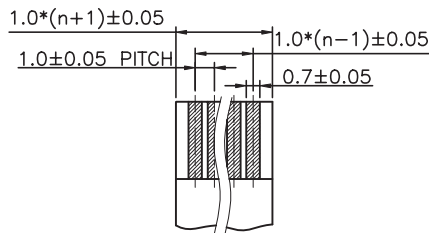
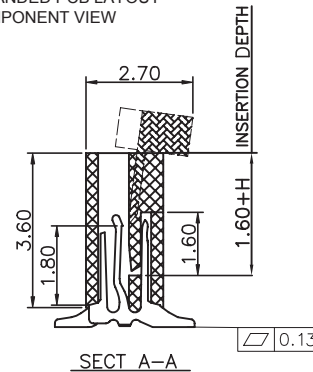
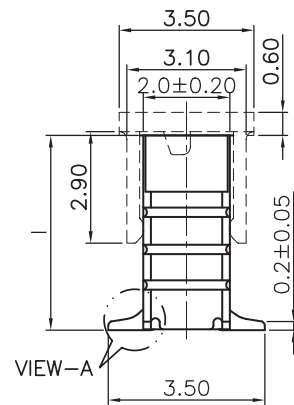
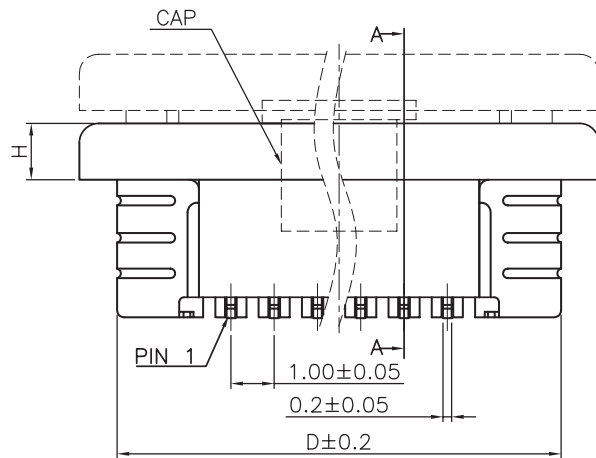

APPLICABLE FFC LAYOUT 5
 (THICKNESS: FROM 0.29 MM to 0.34 MM)

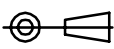
RoHS Compliant		*NOTE: theoretical value related to the Tin plating; however, due to the sensitive actuator, we recommend not to make more than 1 or 2 cycles in order to maintain acceptable mechanical & electrical conditions		PROJECTION:	GENERAL TOLERANCE		DESCRIPTION: 1.0MM ZIF FPC VERTICAL CONTACT TYPE - TAPE & REEL PACKAGING WITH CAP WERI PART NO: 686 3 xx 124 422	SIZE A4
G	31-MAR-14	FFC THICKNESS	QL		.X = +/- 0.2			
F	13-DEC-13	TPK UPDATE	QL		.XX = +/- 0.15			
E	18-SEP-12	MC NOTE	GG					
D	11-JAN-11	COPLANARITY	GG					
C	27-MAY-10	STANDARD	JP					
B	27-MAY-10	DELETE 2 PIN	JP					
A	20-FEB-09	PDF	JP					
REV	DATE	FILE	BY					

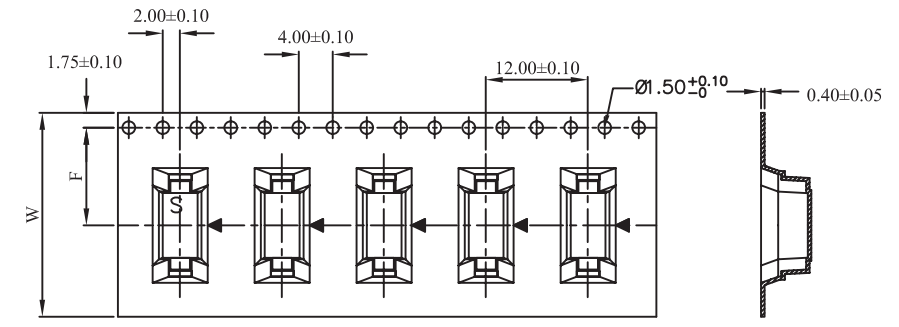
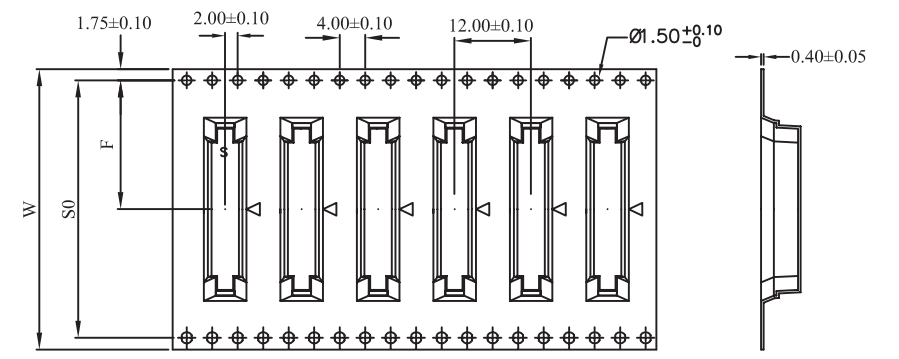
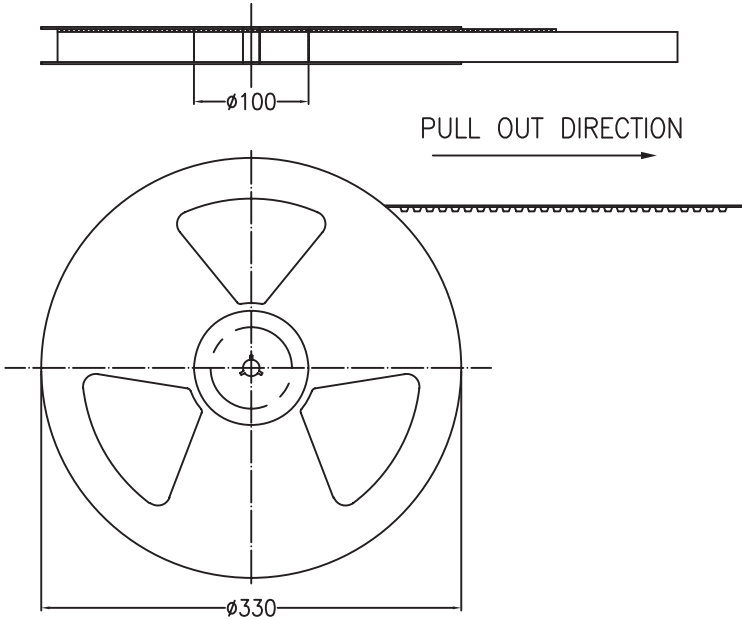

PART NO.	4-8PIN	9-15PIN	16-24PIN	25-30PIN
W	24.00	32.00	44.00	52.00
F	11.50	14.20	20.20	24.20
S0	--	28.40	40.40	48.40

RoHS Compliant				PROJECTION: 	GENERAL TOLERANCE .X = ± 0.2 .XX = ± 0.15		DESCRIPTION: 1.0MM ZIF FPC VERTICAL CONTACT TYPE - TAPE & REEL PACKAGING WITH CAP WERI PART NO: 6863 xx 124422	SIZE A4
G								
F								
E								
D								
C				APPROVAL: RJ	UNIT: MM			
B					SCALE:			
A					SHEET: 2/2			
REV	DATE	FILE	BY		DRAW: PEARL			

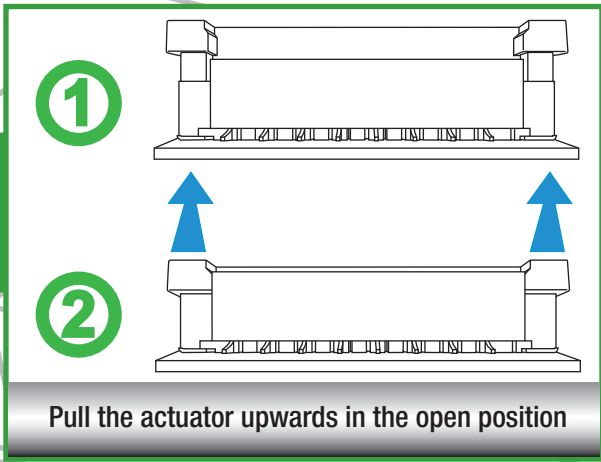

A

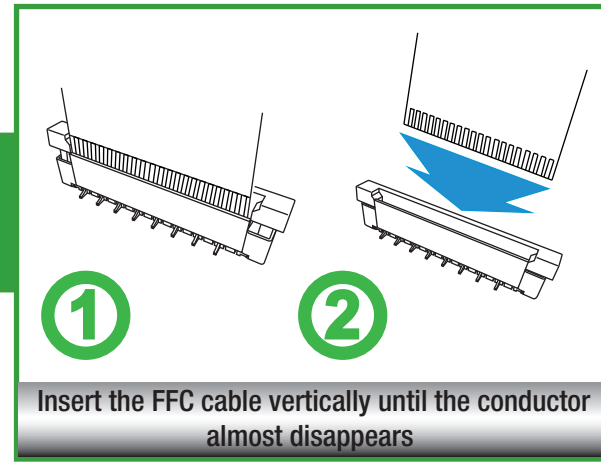

B

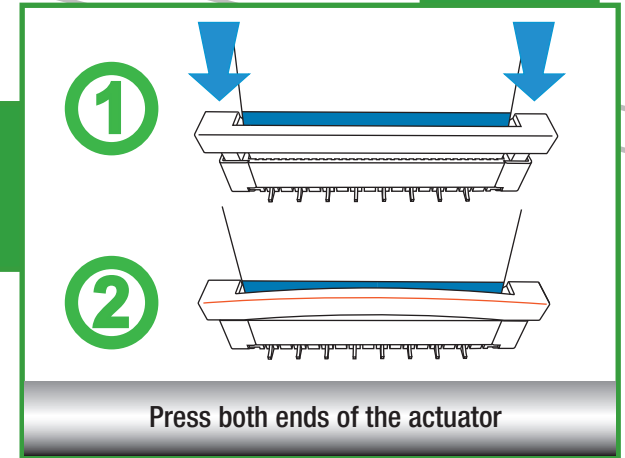
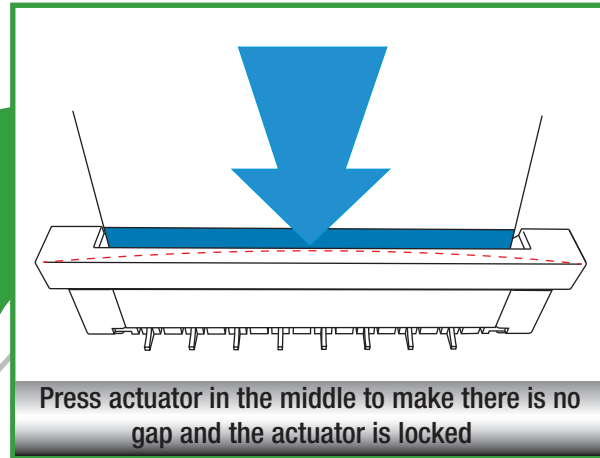

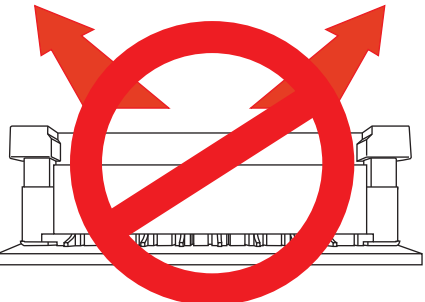

Pull the actuator as horizontally as possible by a proper force

A

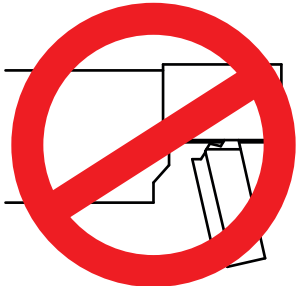

Do not pull the actuator too far otherwise the stop limit (hook on actuator) may be broken

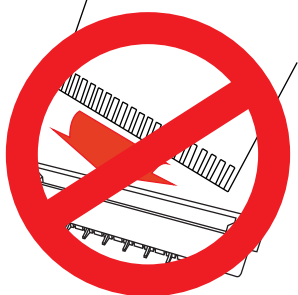

Do not keep FFC inclined when insertion

B

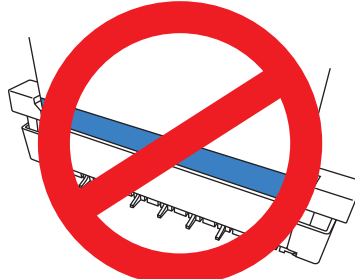

Don't keep conductor toward actuator