

REVISIONS			
LTR	DESCRIPTION	DATE (YR-MO-DA)	APPROVED
F	Add peak current to absolute maximum ratings. Editorial changes throughout.	92-11-24	M. A. FRYE
G	Changes in accordance with NOR 5962-R144-95.	95-10-20	M. A. FRYE
H	Make corrections to the switch operation table in 3.3.1. Update boilerplate to reflect current requirements. -rrp	03-03-10	R. MONNIN

CURRENT CAGE CODE 67268

THE ORIGINAL FIRST SHEET OF THIS DRAWING HAS BEEN REPLACED.

REV																				
SHEET																				
REV																				
SHEET																				
REV STATUS	REV	H	H	H	H	H	H	H	H	H	H	H	H	H	H					
OF SHEETS	SHEET	1	2	3	4	5	6	7	8	9	10	11	12							
PMIC N/A	PREPARED BY Gary J. Zahn		<p align="center">DEFENSE SUPPLY CENTER COLUMBUS COLUMBUS, OHIO 43216 http://www.dsc.dla.mil</p>																	
<p align="center">STANDARD MICROCIRCUIT DRAWING</p> <p>THIS DRAWING IS AVAILABLE FOR USE BY ALL DEPARTMENTS</p> <p>AND AGENCIES OF THE DEPARTMENT OF DEFENSE</p> <p align="center">AMSC N/A</p>	CHECKED BY William E. Sharp																			
	APPROVED BY N. A. Hauck																			
	DRAWING APPROVAL DATE 81-10-01																			
	REVISION LEVEL H	SIZE A	CAGE CODE 14933	81006																
		SHEET 1 OF 12																		

1. SCOPE

1.1 Scope. This drawing describes device requirements for MIL-STD-883 compliant, non-JAN class level B microcircuits in accordance with MIL-PRF-38535, appendix A.

1.2 Part or Identifying Number (PIN). The complete PIN is as shown in the following example:

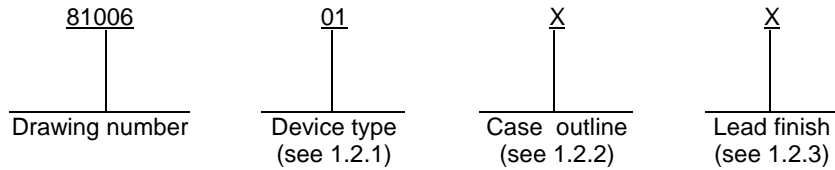

1.2.1 Device type(s). The device type(s) identify the circuit function as follows:

<u>Device type</u>	<u>Generic number</u>	<u>Circuit function</u>
01	IH5040, DG5140	One-channel, 75 ohms, SPST switch
02	IH5041, DG5141	Two-channel, 75 ohms, SPST switch
03	IH5042, DG5142	One-channel, 75 ohms, SPDT switch
04	IH5043, DG5143	Two-channel, 75 ohms, SPDT switch
05	IH5044, DG5144	One-channel, 75 ohms, DPST switch
06	IH5045, DG5145	Two-channel, 75 ohms, DPST switch
07	IH5046	One-channel, 75 ohms, DPDT switch
08	IH5047	One-channel, 75 ohms, 4PST switch
09	IH5140, HI5040	One-channel, 75 ohms, SPST switch
10	IH5141, HI5041	Two-channel, 75 ohms, SPDT switch
11	IH5142, HI5042	One-channel, 75 ohms, SPDT switch
12	IH5143, HI5043	Two-channel, 30 ohms, SPDT switch
13	IH5144, HI5044	One-channel, 30 ohms, DPST switch
14	IH5145, HI5045	Two-channel, 75 ohms, DPST switch
15	HI5046	One-channel, 75 ohms, DPDT switch
16	IH5047, HI5047	One-channel, 75 ohms, 4PST switch
17	HI5046A	One-channel, 30 ohms, DPDT switch
18	HI5047A	One-channel, 30 ohms, 4PST switch
19	IH5148, HI5048	Two-channel, 30 ohms, SPST switch
20	IH5149, HI5049	Two-channel, 30 ohms, DPST switch
21	IH5150, HI5050	One-channel, 30 ohms, SPDT switch
22	IH5151, HI5051	Two-channel, 30 ohms, SPDT switch

1.2.2 Case outline(s). The case outline(s) are as designated in MIL-STD-1835 and as follows:

<u>Outline letter</u>	<u>Descriptive designator</u>	<u>Terminals</u>	<u>Package style</u>
A	GDFP5-F14 or CDFP6-F14	14	Flat pack
E	GDIP1-T16 or CDIP2-T16	16	Dual-in-line
I	MACY1-X10	10	Can
2	CQCC1-N20	20	Square leadless chip carrier
X	CDFP3-F14	14	Flat pack

1.2.3 Lead finish. The lead finish is as specified in MIL-PRF-38535, appendix A.

STANDARD MICROCIRCUIT DRAWING DEFENSE SUPPLY CENTER COLUMBUS COLUMBUS, OHIO 43216-5000	SIZE A		81006
		REVISION LEVEL H	SHEET 2

1.3 Absolute maximum ratings.

V+ - V-	33 V dc
V+ - V _D	30 V dc
V _D - V-	30 V dc
V _D - V _S	±22 V dc
V _L - V-	33 V dc
V _L - V _{IN}	30 V dc
V _L - V _R	20 V dc
V _{IN} - V _R	20 V dc
V _R - V-	33 V dc
V _R - V _{IN}	2 V dc
Current (any terminal except S or D).....	30 mA
Peak current (source to drain) <u>1/</u>	80 mA
Storage temperature range	-65°C to +150°C
Lead temperature (soldering, 10 seconds)	+300°C
Junction temperature (T _J).....	+175°C
Power dissipation, (P _D) <u>2/</u> :	
Cases A and X at T _A = +125°C	350 mW
Case E at T _A = +125°C	400 mW
Case I at T _A = +125°C	350 mW
Case 2 at T _A = +125°C	350 mW

1.4 Recommended operating conditions.

+V _{CC}	+15 V dc
-V _{CC}	-15 V dc
V _R	0 V dc
V _L	5 V dc
Ambient operating temperature range (T _A)	-55°C to +125°C
Thermal resistance, junction-to-case (θ _{JC})	See MIL-STD-1835

2. APPLICABLE DOCUMENTS

2.1 Government specification, standards, and handbooks. The following specification, standards, and handbooks form a part of this drawing to the extent specified herein. Unless otherwise specified, the issues of these documents are those listed in the issue of the Department of Defense Index of Specifications and Standards (DoDISS) and supplement thereto, cited in the solicitation.

SPECIFICATION

DEPARTMENT OF DEFENSE

MIL-PRF-38535 -- Integrated Circuits, Manufacturing, General Specification for.

STANDARDS

DEPARTMENT OF DEFENSE

MIL-STD-883 - Test Method Standard Microcircuits.
MIL-STD-1835 - Interface Standard Electronic Component Case Outlines.

1/ Pulse at 1 ms, 10 percent duty cycle maximum.
2/ For T_A = +100°C to +125°C, derate linearly at 12 mW/°C.

STANDARD MICROCIRCUIT DRAWING DEFENSE SUPPLY CENTER COLUMBUS COLUMBUS, OHIO 43216-5000	SIZE A		81006
		REVISION LEVEL H	SHEET 3

HANDBOOKS

DEPARTMENT OF DEFENSE

- MIL-HDBK-103 -- List of Standard Microcircuit Drawings.
- MIL-HDBK-780 - Standard Microcircuit Drawings.

(Unless otherwise indicated, copies of the specification, standards, and handbooks are available from the Standardization Document Order Desk, 700 Robbins Avenue, Building 4D, Philadelphia, PA 19111-5094.)

2.2 Order of precedence. In the event of a conflict between the text of this drawing and the references cited herein, the text of this drawing takes precedence. Nothing in this document, however, supersedes applicable laws and regulations unless a specific exemption has been obtained.

3. REQUIREMENTS

3.1 Item requirements. The individual item requirements shall be in accordance with MIL-PRF-38535, appendix A for non-JAN class level B devices and as specified herein. Product built to this drawing that is produced by a Qualified Manufacturer Listing (QML) certified and qualified manufacturer or a manufacturer who has been granted transitional certification to MIL-PRF-38535 may be processed as QML product in accordance with the manufacturers approved program plan and qualifying activity approval in accordance with MIL-PRF-38535. This QML flow as documented in the Quality Management (QM) plan may make modifications to the requirements herein. These modifications shall not affect form, fit, or function of the device. These modifications shall not affect the PIN as described herein. A "Q" or "QML" certification mark in accordance with MIL-PRF-38535 is required to identify when the QML flow option is used.

3.2 Design, construction, and physical dimensions. The design, construction, and physical dimensions shall be as specified in MIL-PRF-38535, appendix A and herein.

3.2.1 Case outline(s). The case outline(s) shall be in accordance with 1.2.2 herein.

3.2.2 Terminal connections. The terminal connections shall be as specified on figure 1.

3.3 Electrical performance characteristics. Unless otherwise specified herein, the electrical performance characteristics are as specified in table I and shall apply over the full ambient operating temperature range.

3.3.1 Switch operation. The analog switches listed below are guaranteed to turn "on" with either a "low" input ($V_R \leq V_{IL} \leq 0.8 V$) or "high" input ($2.4 V \leq V_{IH} \leq V_{IL}$) as specified below (see figure 1).

Device types	V_{IN}	Channels ON	Channels OFF
01, 09	2.4 V dc	1	
	0.8 V dc		1
02, 10, 05, 13, 19	2.4 V dc	1, 2	
	0.8 V dc		1, 2
03, 11, 21	2.4 V dc	1	2
	0.8 V dc	2	1
04, 12, 22	2.4 V dc	1, 2	3, 4
	0.8 V dc	3, 4	1, 2
07, 15, 17	2.4 V dc	2, 3	1, 4
	0.8 V dc	1, 4	2, 3
06, 08, 14, 16, 18, 20	2.4 V dc	1, 2, 3, 4	
	0.8 V dc		1, 2, 3, 4

3.4 Electrical test requirements. The electrical test requirements shall be the subgroups specified in table II. The electrical tests for each subgroup are described in table I.

3.5 Marking. Marking shall be in accordance with MIL-PRF-38535, appendix A. The part shall be marked with the PIN listed in 1.2 herein. In addition, the manufacturer's PIN may also be marked as listed in MIL-HDBK-103 (see 6.6 herein). For packages where marking of the entire SMD PIN number is not feasible due to space limitations, the manufacturer has the option of not marking the "5962-" on the device.

STANDARD MICROCIRCUIT DRAWING DEFENSE SUPPLY CENTER COLUMBUS COLUMBUS, OHIO 43216-5000	SIZE A		81006
		REVISION LEVEL H	SHEET 4

TABLE I. Electrical performance characteristics.

Test	Symbol	Conditions -55°C ≤ T _A ≤ +125°C V _{CC} = ±15 V unless otherwise specified	Group A subgroups	Device type	Limits		Unit
					Min	Max	
Drain source "ON" resistance	R _{DS}	V _D = -10 V, I _S = 10 mA,	1, 3	1 - 16		75	Ω <u>1/</u>
			2			150	
			1, 3	17 - 22		45	
			2			50	
		V _D = 10 V, I _S = -10 mA,	1, 3	1 - 16		75	
			2			150	
			1, 3	17 - 22		45	
			2			50	
		V _D = -7.5 V, I _S = 10 mA, V _{CC} = ±10 V <u>2/</u>	1, 3	All		75	
			2			150	
		V _D = 7.5 V, I _S = -10 mA, V _{CC} = ±10 V <u>2/</u>	1, 3			75	
			2			150	
Channel "ON" leakage current	I _{D(ON)}	V _S = V _D = 10 V, See 3.3.1 for V _{IN}	2, 3	All	-200	200	nA
			1		-2	2	
		V _S = V _D = -10 V, See 3.3.1 for V _{IN}	2, 3		-200	200	
			1		-2	2	
Drain "OFF" leakage current	I _{D(OFF)}	V _S = -10 V, V _D = 10 V, See 3.3.1 for V _{IN}	2, 3	All	-100	100	nA
			1		-1	1	
		V _S = 10 V, V _D = -10 V, See 3.3.1 for V _{IN}	2, 3		-100	100	
			1		-1	1	
Source "OFF" leakage current	I _{S(OFF)}	V _S = 10 V, V _D = -10 V, See 3.3.1 for V _{IN}	2, 3	All	-100	100	nA
			1		-1	1	
		V _S = -10 V, V _D = 10 V, See 3.3.1 for V _{IN}	2, 3		-100	100	
			1		-1	1	
Input current, input voltage low	I _{IL}	V _{IN} = 0 V	1, 3	All	-1	1	μA
			2		-10	1	
Input current, input voltage high	I _{IH}	V _{IN} = 2.4 V, 5 V	1, 3	All	-1	1	μA
			2		-1	10	
Positive supply current	+I _{CC}	V _{IN} = 0 V, 5 V	1, 3	1-8		10	μA
			2			100	
			1	9 - 22		200	
			2, 3			300	
Negative supply current	-I _{CC}	V _{IN} = 0 V, 5 V	1, 3	1 - 8	-10		μA
			2		-100		
			1	9 - 22	-200		
			2, 3		-300		

See footnotes at end of table.

STANDARD MICROCIRCUIT DRAWING DEFENSE SUPPLY CENTER COLUMBUS COLUMBUS, OHIO 43216-5000	SIZE A		81006
		REVISION LEVEL H	SHEET 5

TABLE I. Electrical performance characteristics – Continued.

Test	Symbol	Conditions -55°C ≤ T _A ≤ +125°C V _{CC} = ±15 V unless otherwise specified	Group A subgroups	Device type	Limits		Unit
					Min	Max	
Logic supply current	+I _L	V _{IN} = 0 V, 5 V	1, 3	1 - 8		10	μA
			2			100	
			1	9 - 22		-200	
			2, 3			-300	
Reference supply current	+I _R	V _{IN} = 0 V, 5 V	1, 3	1 - 8	-10		μA
			2			-100	
			1	9 - 22	-200		
			2, 3			-300	
Turn-on time	t _{ON}		11	1 - 8		375	ns
			9			450	
			10			550	
			11	9 - 22		450	
			9			500	
			10			800	
Turn-off time	t _{OFF}		11	1 - 8		250	ns
			9			250	
			10			400	
			11	9 - 22		350	
			9			450	
			10			600	
Single channel isolation <u>2/</u>	V _{ISO}	R _L = 100 Ω, f = 100 kHz, V _{IN} = 2 V _{P-P} , C _L = 5 pF, T _A = +25°C	9	All	60		dB
Crosstalk between channels <u>2/</u>	V _{CT}	R _L = 100 Ω, f = 100 kHz, V _{IN} = 2 V _{P-P} , C _L = 5 pF, T _A = +25°C	9	All	60		dB
Charge transfer error <u>2/</u>	V _{CTE}	V _{IN} = 0 V, C _L = 10 nF, T _A = +25°C	9	All		30	mV
Break before make time delay <u>2/</u>	t _D	T _A = +25°C	9	03, 04, 07	5		ns
Driver input capacitance <u>2/</u>	C _A	V _{IN} = 0 V, T _A = +25°C	9	All		45	pF
Switch input capacitance <u>2/</u>	C _{IS}	Switch off, T _A = +25°C	9	All		60	pF
Switch output capacitance <u>2/</u>	C _{OS}	Switch off, T _A = +25°C	9	All		60	pF

1/ The listed resistance limits correspond to the following voltage values:

45 Ω and 75 Ω – ±9.25 V, ±6.75 V

50 Ω and 150 Ω - ±8.50 V, ±6.0 V

2/ If not tested, shall be guaranteed to the limits specified in table I herein.

STANDARD MICROCIRCUIT DRAWING DEFENSE SUPPLY CENTER COLUMBUS COLUMBUS, OHIO 43216-5000	SIZE A		81006
		REVISION LEVEL H	SHEET 6

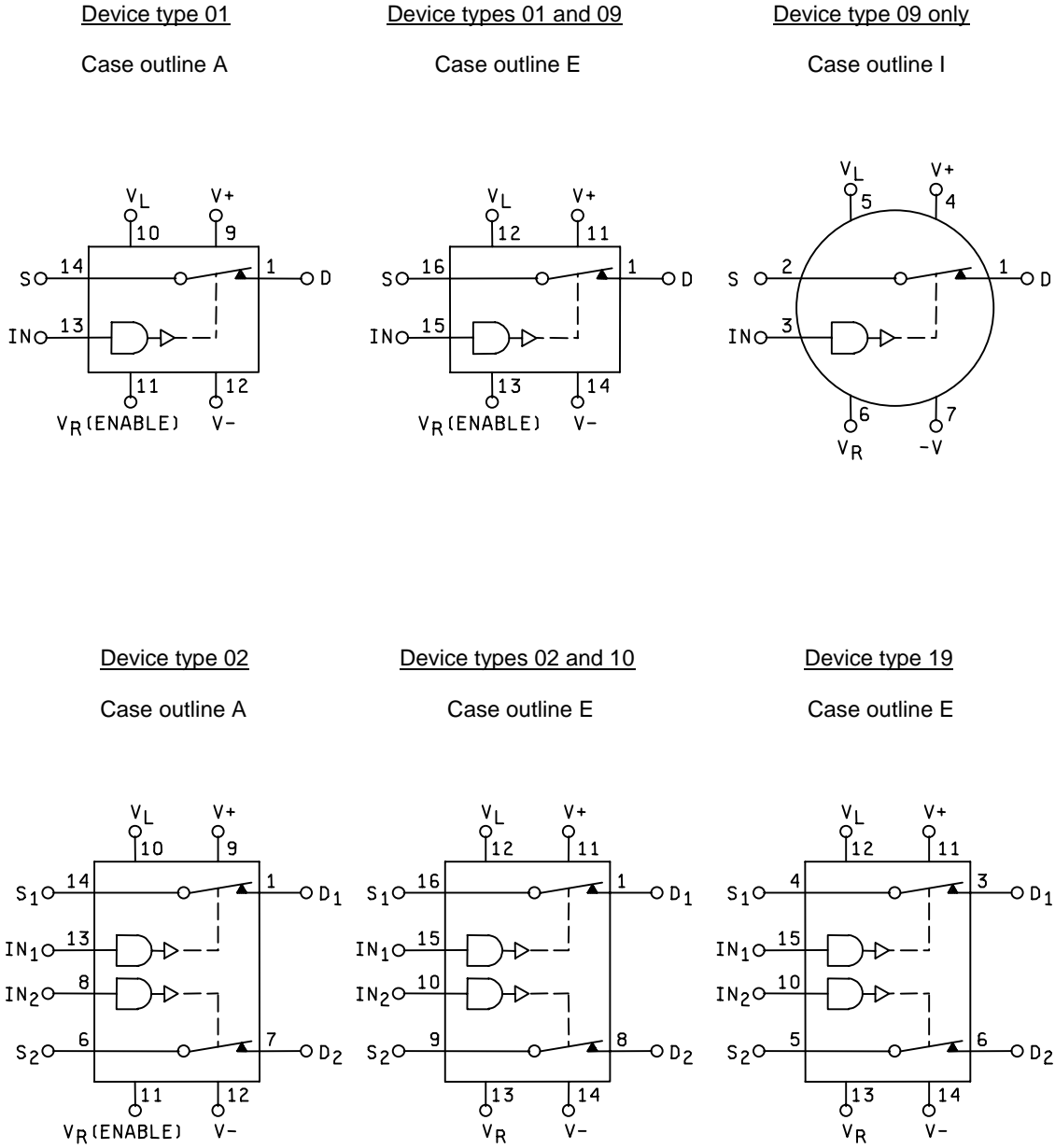
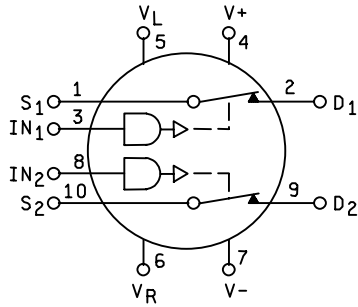

FIGURE 1. Terminal connections.

STANDARD MICROCIRCUIT DRAWING DEFENSE SUPPLY CENTER COLUMBUS COLUMBUS, OHIO 43216-5000	SIZE A		81006
		REVISION LEVEL H	SHEET 7

Device types 02 and 10

Case outline I



Device type 03

Case outline A

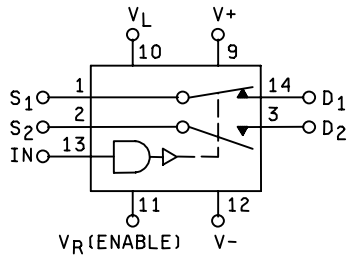

Device types 03, 11, and 21

Case outline E

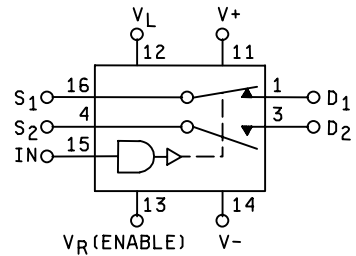

Device type 04

Case outline A

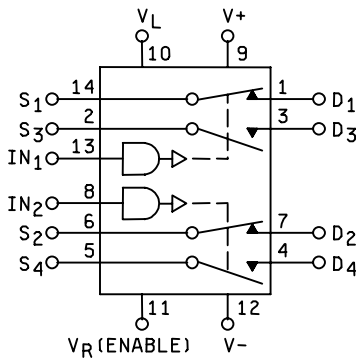

Device types 04, 12, and 22

Case outline E

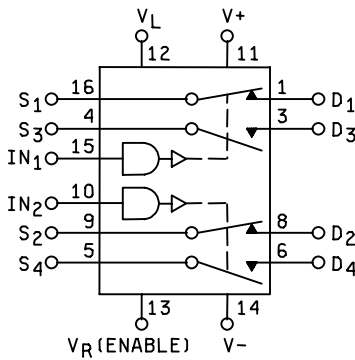

Case outline 2

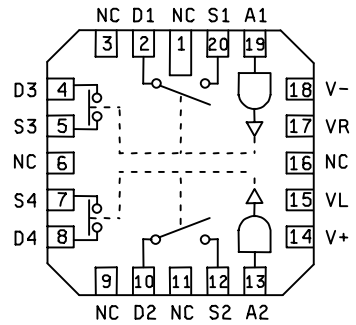

FIGURE 1. Terminal connections – Continued.

**STANDARD
MICROCIRCUIT DRAWING**
DEFENSE SUPPLY CENTER COLUMBUS
COLUMBUS, OHIO 43216-5000

SIZE
A

81006

REVISION LEVEL
H

SHEET
8

Device type 05

Case outline A

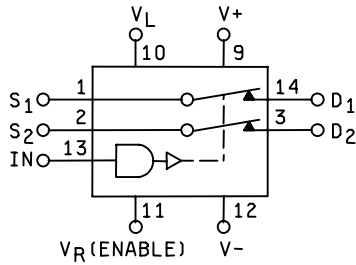

Device types 05 and 13

Case outline E

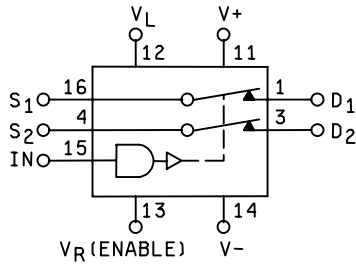

Case outline I

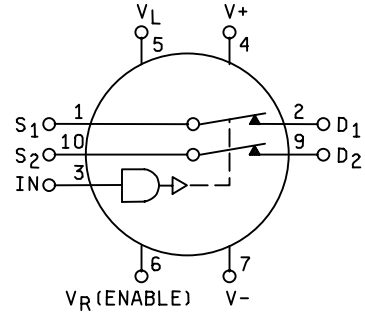

Device type 06

Case outline A and X

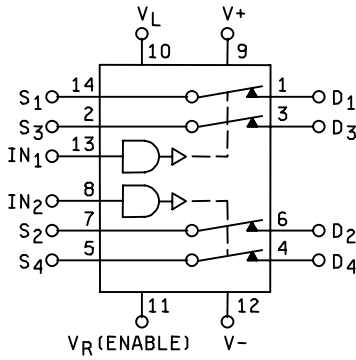

Device types 06, 14, and 20

Case outline E

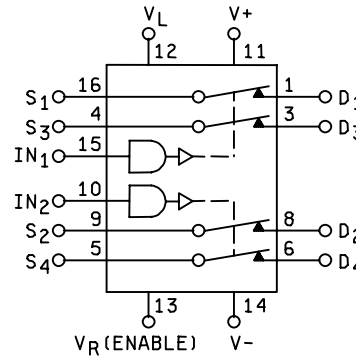

Case outline 2

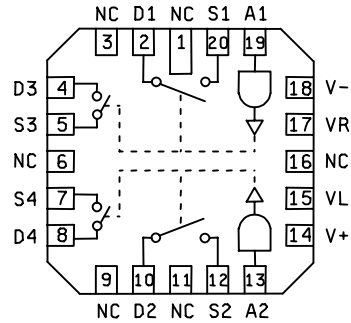
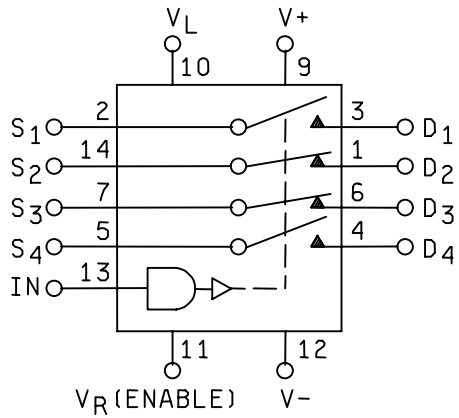

FIGURE 1. Terminal connections – Continued.

STANDARD MICROCIRCUIT DRAWING DEFENSE SUPPLY CENTER COLUMBUS COLUMBUS, OHIO 43216-5000	SIZE A		81006
		REVISION LEVEL H	SHEET 9

Device type 07

Case outline A



Device types 07, 15, and 17

Case outline E

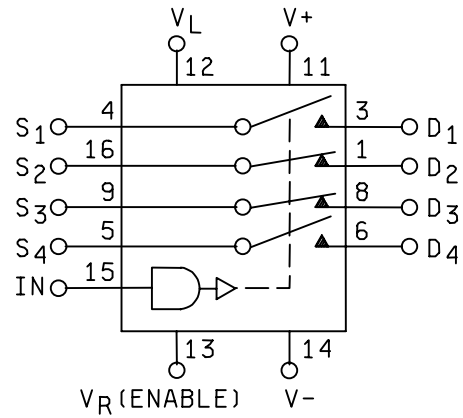

Device type 08

Case outline A

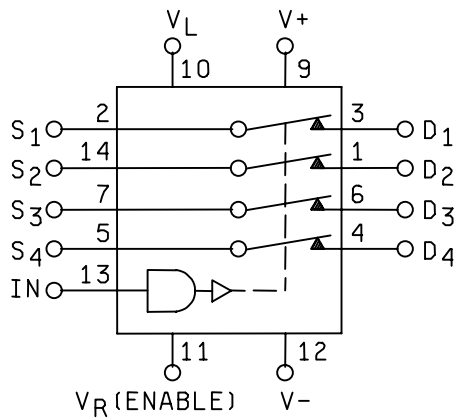

Device types 08, 16, and 18

Case outline E

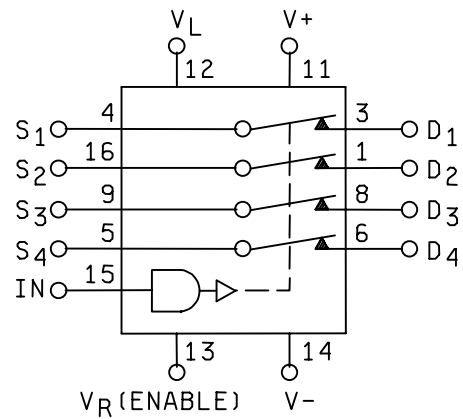

FIGURE 1. Terminal connections – Continued.

**STANDARD
MICROCIRCUIT DRAWING**
DEFENSE SUPPLY CENTER COLUMBUS
COLUMBUS, OHIO 43216-5000

SIZE
A

81006

REVISION LEVEL
H

SHEET
10

3.5.1 Certification/compliance mark. A compliance indicator "C" shall be marked on all non-JAN devices built in compliance to MIL-PRF-38535, appendix A. The compliance indicator "C" shall be replaced with a "Q" or "QML" certification mark in accordance with MIL-PRF-38535 to identify when the QML flow option is used.

3.6 Certificate of compliance. A certificate of compliance shall be required from a manufacturer in order to be listed as an approved source of supply in MIL-HDBK-103 (see 6.6 herein). The certificate of compliance submitted to DSCC-VA prior to listing as an approved source of supply shall affirm that the manufacturer's product meets the requirements of MIL-PRF-38535, appendix A and the requirements herein.

3.7 Certificate of conformance. A certificate of conformance as required in MIL-PRF-38535, appendix A shall be provided with each lot of microcircuits delivered to this drawing.

3.8 Notification of change. Notification of change to DSCC-VA shall be required in accordance with MIL-PRF-38535, appendix A.

3.9 Verification and review. DSCC, DSCC's agent, and the acquiring activity retain the option to review the manufacturer's facility and applicable required documentation. Offshore documentation shall be made available onshore at the option of the reviewer.

4. QUALITY ASSURANCE PROVISIONS

4.1 Sampling and inspection. Sampling and inspection procedures shall be in accordance with MIL-PRF-38535, appendix A.

4.2 Screening. Screening shall be in accordance with method 5004 of MIL-STD-883, and shall be conducted on all devices prior to quality conformance inspection. The following additional criteria shall apply:

a. Burn-in test, method 1015 of MIL-STD-883.

(1) Test condition A, B, C or D. The test circuit shall be maintained by the manufacturer under document revision level control and shall be made available to the preparing or acquiring activity upon request. The test circuit shall specify the inputs, outputs, biases, and power dissipation, as applicable, in accordance with the intent specified in test method 1015 of MIL-STD-883.

(2) $T_A = +125^\circ\text{C}$, minimum.

b. Interim and final electrical test parameters shall be as specified in table II herein, except interim electrical parameter tests prior to burn-in are optional at the discretion of the manufacturer.

4.3 Quality conformance inspection. Quality conformance inspection shall be in accordance with method 5005 of MIL-STD-883 including groups A, B, C, and D inspections. The following additional criteria shall apply.

4.3.1 Group A inspection.

a. Tests shall be as specified in table II herein.

b. Subgroups 4, 5, 6, 7, and 8 in table I, method 5005 of MIL-STD-883 shall be omitted.

STANDARD MICROCIRCUIT DRAWING DEFENSE SUPPLY CENTER COLUMBUS COLUMBUS, OHIO 43216-5000	SIZE A		81006
		REVISION LEVEL H	SHEET 11

TABLE II. Electrical test requirements.

MIL-STD-883 test requirements	Subgroups (in accordance with MIL-STD-883, method 5005, table I)
Interim electrical parameters (method 5004)	----
Final electrical test parameters (method 5004)	1*, 2, 3
Group A test requirements (method 5005)	1, 2, 3, 9, 10, 11
Groups C and D end-point electrical parameters (method 5005)	1

* PDA applies to subgroup 1.

4.3.2 Groups C and D inspections.

- a. End-point electrical parameters shall be as specified in table II herein.
- b. Steady-state life test conditions, method 1005 of MIL-STD-883.
 - (1) Test condition A, B, C, or D. The test circuit shall be maintained by the manufacturer under document revision level control and shall be made available to the preparing or acquiring activity upon request. The test circuit shall specify the inputs, outputs, biases, and power dissipation, as applicable, in accordance with the intent specified in test method 1005 of MIL-STD-883.
 - (2) $T_A = +125^{\circ}\text{C}$, minimum.
 - (3) Test duration: 1,000 hours, except as permitted by method 1005 of MIL-STD-883.

5. PACKAGING

5.1 Packaging requirements. The requirements for packaging shall be in accordance with MIL-PRF-38535, appendix A.

6. NOTES

6.1 Intended use. Microcircuits conforming to this drawing are intended for use for Government microcircuit applications (original equipment), design applications, and logistics purposes.

6.2 Replaceability. Microcircuits covered by this drawing will replace the same generic device covered by a contractor-prepared specification or drawing.

6.3 Configuration control of SMD's. All proposed changes to existing SMD's will be coordinated with the users of record for the individual documents. This coordination will be accomplished using DD Form 1692, Engineering Change Proposal.

6.4 Record of users. Military and industrial users shall inform Defense Supply Center Columbus when a system application requires configuration control and the applicable SMD. DSCC will maintain a record of users and this list will be used for coordination and distribution of changes to the drawings. Users of drawings covering microelectronics devices (FSC 5962) should contact DSCC-VA, telephone (614) 692-0544.

6.5 Comments. Comments on this drawing should be directed to DSCC-VA, Columbus, Ohio 43216-5000, or telephone (614) 692-0547.

6.6 Approved sources of supply. Approved sources of supply are listed in MIL-HDBK-103. The vendors listed in MIL-HDBK-103 have agreed to this drawing and a certificate of compliance (see 3.6 herein) has been submitted to and accepted by DSCC-VA.

STANDARD MICROCIRCUIT DRAWING DEFENSE SUPPLY CENTER COLUMBUS COLUMBUS, OHIO 43216-5000	SIZE A		81006
		REVISION LEVEL H	SHEET 12

STANDARD MICROCIRCUIT DRAWING BULLETIN

DATE: 03-03-10

Approved sources of supply for SMD 81006 are listed below for immediate acquisition information only and shall be added to MIL-HDBK-103 and QML-38535 during the next revision. MIL-HDBK-103 and QML-38535 will be revised to include the addition or deletion of sources. The vendors listed below have agreed to this drawing and a certificate of compliance has been submitted to and accepted by DSCC-VA. This bulletin is superseded by the next dated revision of MIL-HDBK-103 and QML-38535.

Standard microcircuit drawing PIN <u>1</u> /	Vendor CAGE number	Vendor similar PIN <u>2</u> /	Reference military specification PIN
8100601AA	<u>3</u> /		M38510/10501BAA
8100601EA	1ES66	IH5040MJE/883B	M38510/10501BEA
	<u>3</u> /	DG5140AK	
8100602AA	<u>3</u> /		M38510/10502BAA
8100602EA	1ES66	IH5041MJE/883B	M38510/10502BEA
	<u>3</u> /	DG5141AK	
8100602IA	<u>3</u> /	DG5141AA	M38510/10502BIA
8100603AA	<u>3</u> /		M38510/10503BAA
8100603EA	1ES66	IH5042MJE/883B	M38510/10503BEA
	<u>3</u> /	DG5142AK	
8100604AA	<u>3</u> /		M38510/10504BAA
8100604EA	<u>3</u> /	IH5043MJE	M38510/10504BEA
	1ES66	IH5043MJE/883B	
	<u>3</u> /	DG5143AK	
8100605AA	<u>3</u> /		M38510/10505BAA
8100605EA	1ES66	IH5044MJE/883B	M38510/10505BEA
	<u>3</u> /	DG5144AK	
8100605IA	<u>3</u> /	DG5144AA	M38510/10505BIA
8100606AA	<u>3</u> /	IH5045MFD/883B	M38510/10506BAA
8100606EA	1ES66	IH5045MJE/883B	M38510/10506BEA
	<u>3</u> /	DG5145AK	
8100606XC	1ES66	IH5045MFD/883B	
8100607AA	<u>3</u> /		M38510/10507BAA
8100607EA	<u>3</u> /		M38510/10507BEA
8100608AA	<u>3</u> /		M38510/10508BAA
8100608EA	1ES66	IH5047MJE/883B	M38510/10508BEA
8100609EA	1ES66	IH5140MJE/883B	M38510/10501BEA
	<u>3</u> /	HI1-5040/883	
8100609IA	<u>3</u> /		M38510/10501BIA

See footnotes at end of table.

STANDARD MICROCIRCUIT DRAWING BULLETIN – Continued.

Standard microcircuit drawing PIN <u>1/</u>	Vendor CAGE number	Vendor similar PIN <u>2/</u>	Reference military specification PIN
8100610EA	1ES66	IH5141MJE/883B	M38510/10502BEA
	<u>3/</u>	IH5141MJE	
	34371	HI1-5041/883	
8100610IA	<u>3/</u>		M38510/10502BIA
8100611EA	1ES66	IH5142MJE/883B	M38510/10503BEA
	<u>3/</u>	IH5142MJE	
	34371	HI1-5042/883	
8100612EA	1ES66	IH5143MJE/883B	M38510/10504BEA
	<u>3/</u>	IH5143MJE	
	34371	HI1-5043/883	
81006122A	34371	HI4-5043/883	---
8100613EA	1ES66	IH5144MJE/883B	M38510/10505BEA
	<u>3/</u>	IH5144MJE	
	<u>3/</u>	HI1-5044/883	
8100613IA	<u>3/</u>		M38510/10505BIA
8100614EA	1ES66	IH5145MJE/883B	M38510/10506BEA
	<u>3/</u>	IH5145MJE	
	<u>3/</u>	HI1-5045/883	
81006142A	<u>3/</u>	HI4-5045/883	---
8100615EA	<u>3/</u>	HI1-5046/883	M38510/10507BEA
8100616EA	1ES66	IH5047MJE/883B	M38510/10508BEA
	<u>3/</u>	HI1-5047/883	
8100617EA	34371	HI1-5046A/883	---
8100618EA	<u>3/</u>	HI1-5047A/883	---
8100619EA	<u>3/</u>	IH5148MJE/883B	---
	<u>3/</u>	HI1-5048/883	

See footnotes at end of table.

STANDARD MICROCIRCUIT DRAWING BULLETIN – Continued.

Standard microcircuit drawing PIN <u>1/</u>	Vendor CAGE number	Vendor similar PIN <u>2/</u>	Reference military specification PIN
8100620EA	1ES66	IH5149MJE/883B	---
	<u>3/</u>	HI1-5049/883	
81006202A	<u>3/</u>	HI4-5049/883	---
8100621EA	1ES66	IH5150MJE/883B	---
	<u>3/</u>	HI1-5050/883	
8100622EA	<u>3/</u>	IH5151MJE	---
	34371	HI1-5051/883	
	1ES66	IH5151MJE/883B	
81006222A	34371	HI4-5051/883	---

1/ The lead finish shown for each PIN representing a hermetic package is the most readily available from the manufacturer listed for that part. If the desired lead finish is not listed contact the vendor to determine its availability.

2/ Caution. Do not use this number for item acquisition. Items acquired to this number may not satisfy the performance requirements of this drawing.

3/ Not available from an approved source of supply.

Vendor CAGE
number

Vendor name
and address

1ES66

Maxim Integrated Products
120 San Gabriel Drive
Sunnyvale, CA 94086

34371

Intersil Corporation
2401 Palm Bay Blvd
P.O. Box 883
Melbourne, FL 32902-0883

The information contained herein is disseminated for convenience only and the Government assumes no liability whatsoever for any inaccuracies in the information bulletin.