

PRORELSIC 125

CO 52

5 000 h / 125°C

10V ... 450V	1 μ F ... 25 000 μ F	\emptyset 6,5 mm ... \emptyset 25 mm	- 55°C + 125°C	Long Life Time
--------------	------------------------------	--	----------------	----------------



APPLICATIONS

- Coupling / decoupling
- Smoothing
- Energy storage
- High frequency power supply system
- Telecommunication - military applications
- Mobile and aircraft installations

Insulating aluminum case

Axial tin coated copper leads

Welded chain, providing perfect continuity of the circuit.

Tolerance on capacitance at 20°C : - 10 + 50 %

(on request) : - 10 + 30 %

Operating temperature : - 55°C + 125°C

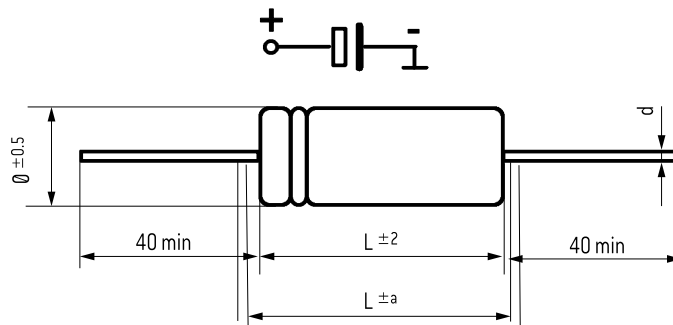

\emptyset (mm)	d	a
6,5 - 18	0,8	4
21	1	4
25	1	8

RESISTANCE TO VIBRATIONS

Hb (mm)	
(Hz)	10 - 2000 Hz
Amplitude	1,5 mm
Acceleration	20 g - 196 m/s ²
t (h)	3 x 2 h

SPECIFICATIONS

NFC 83 110 - Model CO 52 - Long life

DIN 40040 FKD

DIN 41 257 - DIN 41 240

CECC 30 301-802 Issue 2

IEC 60 384.4 long life

Climatic category GPF: -55°C + 125°C / 56 days

Standard endurance test at $U_R = 2000$ h / 125°C

WITHSTAND STRENGTH OF INSULATING SLEEVE

Insulating resistance at 20°C between leads and mounting hardware : 100 M Ω

Test voltage at 50 Hz 1 min. between leads and mounting hardware : 1000 V

Fire resistance : self extinguish 30 s (IEC 60 695-2-2) without PVC.

PRORELSIC 125

CO 52

5 000 h / 125°C

Capacitance [μ F]	Case		ESR		Z F(1) +20°C max. [Ω]	II +20°C 5 min. max. [μ A]	I ~ 100 Hz		Code
	Ø (mm)	L (mm)	Typic [Ω]	Max. [Ω]			+85°C max. [A]	+125°C max. [A]	
Rated voltage 10 V									
47	6,5	15	3,6	5,42	4	5	0,22	0,1	A 701020
68	6,5	19	2,5	3,74	2,8	7	0,29	0,13	A 701021
100	6,5	15	3,6	5,42	4	8	0,22	0,1	A 701029
100	8,5	19	1,5	2,25	1,6	8	0,43	0,19	A 701028
150	6,5	19	2,5	3,74	2,8	9	0,29	0,13	A 701030
150	8,5	19	1,35	2,03	1,1	9	0,46	0,2	A 701022
220	10	19	0,77	1,15	0,8	11	0,66	0,3	A 701023
300	8,5	19	1,35	2,03	1,1	13,5	0,46	0,2	A 701031
330	10	25	0,51	0,77	0,5	14	0,92	0,41	A 701024
420	10	19	0,77	1,15	0,8	16	0,66	0,3	A 701032
470	12	25	0,36	0,54	0,4	18	1,21	0,54	A 701025
600	10	25	0,51	0,77	0,5	19	0,92	0,41	A 701033
680	12	30	0,25	0,37	0,3	24	1,57	0,7	A 701026
800	12	25	0,36	0,54	0,4	24	1,21	0,54	A 701034
1000	14	30	0,21	0,31	0,21	34	1,87	0,84	A 701027
1200	12	30	0,25	0,37	0,3	36	1,57	0,7	A 701035
1500	16	30	0,14	0,21	0,19	50	2,02	0,9	A 703020
1700	14	30	0,21	0,31	0,21	51	1,87	0,84	A 703036
2200	18	30	0,11	0,17	0,14	70	3	1,33	A 703021
2400	16	30	0,14	0,21	0,19	72	2,02	0,9	A 703024
3100	18	30	0,11	0,17	0,14	93	3	1,33	A 703025
3300	18	40	0,09	0,13	0,1	100	3,7	1,7	A 703022
4700	21	40	0,06	0,09	0,08	150	5	2,2	A 703023
4800	18	40	0,09	0,13	0,1	150	3,7	1,7	A 703026
6800	25	40	0,05	0,07	0,06	200	6	2,7	A 703500
7000	21	40	0,06	0,09	0,08	210	5	2,2	A 703027
10000	25	40	0,05	0,07	0,06	300	6	2,7	A 703028
10000	25	50	0,033	0,05	0,05	300	8,2	3,7	A 703501
14000	25	50	0,033	0,05	0,05	420	8,2	3,7	A 703029
15000	25	75	0,027	0,04	0,04	450	10	4,9	A 703502
25000	25	75	0,027	0,04	0,04	660	10	4,9	A 703030
Rated voltage 16 V									
33	6,5	15	4,2	6,27	4	5	0,2	0,09	A 701040
47	6,5	19	2,9	4,4	3	8	0,27	0,12	A 701041
68	8,5	19	2	3,04	1,9	8	0,37	0,17	A 701042
100	6,5	15	4,2	6,27	4	9	0,2	0,09	A 701049
100	8,5	19	1,4	2,07	1,1	9	0,45	0,2	A 701043
150	6,5	19	2,9	4,4	3	11	0,27	0,12	A 701050
150	10	19	0,92	1,38	0,8	11	0,61	0,27	A 701044
220	10	25	0,63	0,94	0,6	15	0,83	0,37	A 701045
300	8,5	19	1,4	2,07	1,1	17	0,45	0,2	A 701052
330	12	25	0,41	0,62	0,4	20	1,14	0,51	A 701046
420	10	19	0,92	1,38	0,8	23	0,61	0,27	A 701053
470	12	30	0,33	0,5	0,3	27	1,37	0,61	A 701047
600	10	25	0,63	0,94	0,6	28	1,83	0,37	A 701054
680	14	30	0,25	0,37	0,23	37	1,71	0,77	A 701048
800	12	25	0,41	0,62	0,4	38	1,14	0,51	A 701055
1000	16	30	0,17	0,26	0,16	52	2,24	1	A 703040
1200	12	30	0,33	0,5	0,3	57	1,37	0,61	A 701056
1500	18	30	0,15	0,23	0,16	75	2,5	1,14	A 703041
1700	14	30	0,25	0,37	0,23	81	1,71	0,77	A 701057
2200	18	40	0,1	0,15	0,12	110	3,5	1,6	A 703042
2400	16	30	0,17	0,26	0,16	115	2,24	1	A 703044
3300	21	40	0,066	0,1	0,08	160	4,8	2,1	A 703043
4700	25	40	0,045	0,07	0,07	230	6,4	2,8	A 703510
6800	25	50	0,04	0,06	0,05	330	7,4	3,3	A 703511
10000	25	75	0,033	0,05	0,04	480	9,8	4,4	A 703512

(1) F = 10 kHz [C > 1000 μ F], F = 100 kHz [C \leq 1000 μ F]
 $Z_{typ} = Z_{max} / 2$

PRORELSIC 125

CO 52

5 000 h / 125°C

Capacitance (μF)	Case		ESR		Z F(1) +20°C max. (Ω)	II +20°C 5 min. max. (μA)	I~ 100 Hz		Code
	\emptyset (mm)	L (mm)	Typic (Ω)	Max. (Ω)			+85°C max. (A)	+125°C max. (A)	
Rated voltage 25 V									
15	6,5	15	6,4	10,61	4	4	0,16	0,07	A 701060
22	6,5	19	4,3	7,23	3	6	0,22	0,1	A 701061
47	8,5	19	1,7	2,85	1,6	8	0,26	0,11	A 701068
63	6,5	15	6,4	10,61	4	19	0,16	0,07	A 701069
68	10	19	1,4	2,34	1,2	9	0,44	0,2	A 701062
90	6,5	19	4,3	7,23	3	11	0,22	0,1	A 701070
100	10	19	0,95	1,59	0,8	12	0,6	0,27	A 701063
120	10	19	1,4	2,34	1,2	13	0,44	0,2	A 701072
150	10	25	0,63	1,06	0,6	15	0,83	0,37	A 701064
170	8,5	19	1,7	2,85	1,6	16	0,26	0,11	A 701071
220	12	25	0,48	0,72	0,48	21	1,05	0,47	A 701065
240	10	19	0,95	1,59	0,8	21	0,6	0,27	A 701073
330	12	30	0,32	0,48	0,36	29	1,39	0,62	A 701066
350	10	25	0,63	1,06	0,6	29	0,83	0,37	A 701074
460	12	25	0,48	1,72	0,48	39	1,05	0,47	A 701075
470	14	30	0,29	0,44	0,26	39	1,59	0,71	A 701067
680	16	30	0,2	0,3	0,23	55	2,1	0,92	A 703060
700	12	30	0,32	0,48	0,36	55	1,39	0,62	A 701076
1000	18	30	0,15	0,24	0,14	80	2,5	1,14	A 703061
1500	18	40	0,1	0,15	0,1	120	3,5	1,59	A 703062
2200	21	40	0,066	0,1	0,08	170	4,8	2,1	A 703063
3300	25	40	0,045	0,07	0,06	250	6,4	2,8	A 703520
3600	21	40	0,066	0,1	0,08	250	4,8	2,1	A 703064
4700	25	50	0,04	0,06	0,05	360	7,4	3,3	A 703521
6800	25	75	0,033	0,05	0,04	510	9,8	4,4	A 703522
Rated voltage 40 V									
10	6,5	15	8	12,7	5,2	4	0,15	0,07	A 701080
15	6,5	19	5,3	8,49	3,9	6	0,2	0,09	A 701081
32	6,5	15	8	12,7	5,2	8	0,15	0,07	A 701089
33	8,5	19	2,4	3,86	2	8	0,34	0,15	A 701082
44	6,5	19	5,3	8,49	3,9	10	0,2	0,09	A 701090
44	8,5	19	2,4	3,86	2	10	0,34	0,15	A 701091
47	8,5	19	1,7	2,71	1,4	10	0,41	0,18	A 701083
68	10	19	1,2	1,87	1	12	0,53	0,24	A 701084
85	8,5	19	1,7	2,71	1,4	14	0,41	0,18	A 701092
100	10	25	0,8	1,27	0,78	16	0,73	0,33	A 701085
120	10	19	1,2	1,87	1	17	0,53	0,24	A 701093
150	12	25	0,53	0,84	0,52	22	1	0,44	A 701086
170	10	25	0,8	1,27	0,78	22	0,73	0,33	A 701094
220	12	30	0,36	0,57	0,38	30	1,31	0,59	A 701087
230	12	25	0,53	0,84	0,52	30	1	0,44	A 701095
330	14	30	0,32	0,48	0,3	44	1,51	0,68	A 701088
340	12	30	0,36	0,57	0,38	44	1,31	0,59	A 701096
470	16	30	0,23	0,34	0,25	60	1,9	0,86	A 703080
680	18	30	0,15	0,23	0,16	86	2,5	1,14	A 703081
1000	18	40	0,11	0,17	0,12	120	3,4	1,51	A 703082
1500	21	40	0,073	0,11	0,1	180	4,5	2	A 703083
2200	25	40	0,053	0,08	0,06	270	5,9	2,6	A 703530
3300	25	50	0,04	0,06	0,05	400	7,4	3,3	A 703531
4700	25	75	0,033	0,05	0,04	570	9,8	4,4	A 703532

[1] F = 10 kHz (C > 1000 μF), F = 100 kHz (C \leq 1000 μF)

Z typ = Z max / 2

PRORELSIC 125

CO 52

5 000 h / 125°C

Capacitance [μ F]	Case		ESR		Z F(1) +20°C max. [Ω]	II +20°C 5 min. max. [μ A]	I ~ 100 Hz		Code
	Ø (mm)	L (mm)	Typic [Ω]	Max. [Ω]			+85°C max. [A]	+125°C max. [A]	
Rated voltage 63 V									
4,7	6,5	15	9	18	4	3	0,12	0,06	A 701100
10	6,5	19	6,4	11,1	3	6	0,18	0,08	A 701101
15	8,5	19	2,9	5,24	1,6	9	0,31	0,14	A 701102
21	6,5	15	9	18	4	9	0,12	0,06	A 701108
22	8,5	19	2,1	4,2	1,2	9	0,36	0,16	A 701103
28	6,5	19	6,4	11,1	3	9	0,18	0,08	A 701109
28	8,5	19	2,9	5,24	1,6	9	0,31	0,14	A 701110
33	10	19	1,1	2,2	0,8	10	0,56	0,24	A 701104
47	10	25	0,9	1,8	0,6	13	0,69	0,31	A 701105
56	8,5	19	2,1	4,2	1,2	14	0,36	0,16	A 701111
68	10	25	0,7	1,4	0,5	17	0,78	0,35	A 701106
78	10	19	1,1	2,2	0,8	18	0,56	0,24	A 701112
100	12	30	0,4	0,8	0,3	23	1,24	0,56	A 701107
110	10	25	0,7	1,4	0,5	24	0,78	0,35	A 701113
220	16	30	0,27	0,41	0,3	46	1,78	0,8	A 703100
220	12	30	0,4	0,8	0,3	46	1,24	0,56	A 701114
330	18	30	0,2	0,3	0,2	66	2,2	0,99	A 703101
470	18	40	0,13	0,2	0,13	93	3,1	1,4	A 703102
550	16	30	0,27	0,41	0,3	100	1,78	0,8	A 703104
680	21	40	0,1	0,15	0,1	130	3,9	1,73	A 703103
1000	25	40	0,07	0,11	0,08	190	5,1	2,3	A 703540
1500	25	50	0,05	0,08	0,06	290	6,6	3	A 703541
2200	25	75	0,045	0,07	0,05	420	8,4	3,8	A 703542
Rated voltage 100 V									
2,2	6,5	15	15	30	8	2	0,11	0,05	A 701120
4,7	6,5	19	9	15	4,5	5	0,15	0,07	A 701121
6,8	8,5	19	6	10	3	7	0,22	0,1	A 701122
8	6,5	15	15	30	8	8	0,11	0,05	A 701129
10	8,5	19	5,1	8,8	2,3	10	0,23	0,1	A 701123
12	6,5	19	9	15	4,5	10	0,15	0,07	A 701130
15	10	19	3,6	6,5	2	10	0,31	0,14	A 701124
22	10	19	2,5	4,4	1,4	11	0,37	0,16	A 701125
22	8,5	19	5,1	8,8	2,3	11	0,23	0,1	A 701131
33	10	19	2,5	4,4	1,4	14	0,37	0,16	A 701132
33	12	25	1,6	2,8	1,2	14	0,58	0,26	A 701126
47	12	30	1,2	1,8	1	18	0,72	0,32	A 701127
61	12	25	1,6	2,8	1,2	19	0,58	0,26	A 701133
68	14	30	0,9	1,4	0,7	24	0,9	0,4	A 701128
92	12	30	1,2	1,8	1	27	0,72	0,32	A 701134
100	16	30	0,5	0,75	0,5	34	1,31	0,58	A 703120
140	14	30	0,9	1,4	0,7	42	0,9	0,4	A 701135
150	16	30	0,4	0,6	0,4	49	1,46	0,65	A 703123
220	18	40	0,2	0,3	0,2	70	2,5	1,12	A 703121
220	16	30	0,4	0,6	0,4	70	1,46	0,65	A 703124
310	18	40	0,2	0,3	0,2	100	2,5	1,12	A 703125
330	21	40	0,15	0,22	0,15	100	3,2	1,41	A 703122
370	21	40	0,15	0,22	0,15	111	3,2	1,41	A 703126
470	25	40	0,12	0,18	0,12	150	3,9	1,74	A 703550
670	25	40	0,12	0,18	0,12	200	3,9	1,74	A 703127
680	25	50	0,1	0,15	0,1	200	4,7	2,1	A 703128
900	25	50	0,1	0,15	0,1	270	4,7	2,1	A 703130
1000	25	75	0,07	0,1	0,06	300	6,8	3	A 703552
1100	25	75	0,07	0,1	0,06	330	6,8	3	A 703131
2200	25	75	0,04	0,06	0,04	660	8,9	4	A 703553

(1) F = 10 kHz (C > 1000 μ F), F = 100 kHz (C \leq 1000 μ F)
 $Z_{typ} = Z_{max} / 2$

PRORELSIC 125

CO 52

5 000 h / 125°C

Capacitance [μ F]	Case		ESR		Z F(1) +20°C max. [Ω]	II +20°C 5 min. max. [μ A]	I~ 100 Hz		Code
	\emptyset [mm]	L [mm]	Typic [Ω]	Max. [Ω]			+85°C max. [A]	+125°C max. [A]	
Rated voltage 160 V									
1	6,5	15	53	105	18	2	0,06	0,03	A 701140
2	6,5	15	53	105	18	4	0,06	0,03	A 701149
2,2	6,5	19	24	48	12	4	0,09	0,04	A 701141
3	6,5	19	24	48	12	5	0,09	0,04	A 701150
3,3	8,5	19	15	30	6,6	5	0,14	0,06	A 701142
4,7	10	19	8	16	4,6	8	0,2	0,09	A 701143
6	8,5	19	15	30	6,6	10	0,14	0,06	A 701151
6,8	10	25	6	12	3,2	11	0,27	0,12	A 701144
8	10	19	8	16	4,6	12	0,2	0,09	A 701152
10	12	25	5	10	2,4	14	0,33	0,15	A 701145
11	10	25	6	12	3,2	14	0,27	0,12	A 701153
15	12	25	5	10	2,4	18	0,33	0,15	A 701154
15	12	30	3,5	7	1,8	18	0,42	0,19	A 701146
22	12	30	3,5	7	1,8	25	0,42	0,19	A 701155
22	14	30	2,8	5,6	1,1	25	0,51	0,23	A 701147
33	14	30	1,8	2,7	1	36	0,64	0,29	A 701148
47	18	40	1,1	1,7	0,65	45	1,07	0,48	A 703140
68	21	40	0,8	1,2	0,44	65	1,38	0,61	A 703141
100	25	40	0,4	0,6	0,3	100	2,1	0,95	A 703560
150	25	50	0,3	0,5	0,25	140	2,7	1,21	A 703561
220	25	75	0,2	0,3	0,2	210	4	1,79	A 703562
470	25	75	0,12	0,2	0,13	450	5,2	2,3	A 703563
Rated voltage 250 V									
15	18	30	3,3	5	2	25	0,54	0,24	A 703160
22	18	30	2,5	3,8	1,5	37	0,62	0,28	A 703165
33	18	40	1,5	2,3	1	50	0,92	0,41	A 703161
47	25	40	0,9	1,4	0,8	70	1,42	0,64	A 703570
68	25	50	0,73	1,1	0,6	100	1,75	0,78	A 703571
100	25	75	0,45	0,7	0,3	150	2,7	1,2	A 703572
Rated voltage 350 V									
10	18	30	4,2	6,3	3,9	120	0,48	0,22	A 703181
15	18	30	3	4,5	2,7	140	0,57	0,25	A 703184
22	18	40	2	2,9	1,8	180	0,79	0,35	A 703182
30	18	30	3	4,5	2,7	200	0,57	0,25	A 703185
33	21	40	1,3	1,9	1	210	1,07	0,48	A 703183
41	18	40	2	2,9	1,8	230	0,79	0,35	A 703186
47	25	40	1,1	1,7	0,8	250	1,3	0,57	A 703580
100	25	40	1,1	1,7	0,8	450	1,3	0,57	A 703187
Rated voltage 450 V									
6,8	16	30	15	23	5	110	0,24	0,11	A 703210
6,8	18	30	8	12	5	110	0,34	0,16	A 703201
10	16	30	5,5	8,5	4	130	0,39	0,18	A 703211
10	18	30	5,5	8,5	4	130	0,42	0,19	A 703203
15	16	30	15	23	5	160	0,24	0,11	A 703212
15	18	40	4	6	2,7	160	0,56	0,25	A 703204
22	18	30	5,5	8,5	4	200	0,42	0,19	A 703213
22	18	40	3,3	5	2	200	0,62	0,28	A 703208
22	21	40	2,7	4,1	2	200	0,74	0,33	A 703205
33	18	40	4	6	2,7	250	0,56	0,25	A 703214
33	25	40	1,7	2,5	1,5	250	1,03	0,46	A 703590
47	25	40	1,1	1,7	1	300	1,3	0,57	A 703591
50	21	40	2,7	4,1	2	330	0,74	0,33	A 703215

[1] F = 10 kHz [C > 1000 μ F], F = 100 kHz [C \leq 1000 μ F]
 Z typ = Z max / 2

5 000 h / 125°C

PEAK VOLTAGE (V) U_R : rated voltage U_p : Repetitive standard peak voltage (30 s) U_s : Repetitive surge voltage (0,1 s)

Do not overstep this value without damage.

U_R	10 V	16 V	25 V	40 V	63 V	100 V	160 V	250 V	350 V	450 V
U_p	12	18	29	46	72	115	184	288	385	495
U_s							235	340	540	620*

PERMISSIBLE RIPPLE CURRENT I (R.M.S. VALUE)versus frequency f : I_{\sim} : permissible r.m.s. current at 100 Hz

f (Hz)	50	100	300	600	1 000	10 000	$\geq 50 000$
I_{\sim}	$0,8 \times I_{\sim}$	I_{\sim}	$1,2 \times I_{\sim}$	$1,3 \times I_{\sim}$	$1,35 \times I_{\sim}$	$1,5 \times I_{\sim}$	$1,6 \times I_{\sim}$

EXPECTED LIFE

as a function of temperature and ripple current

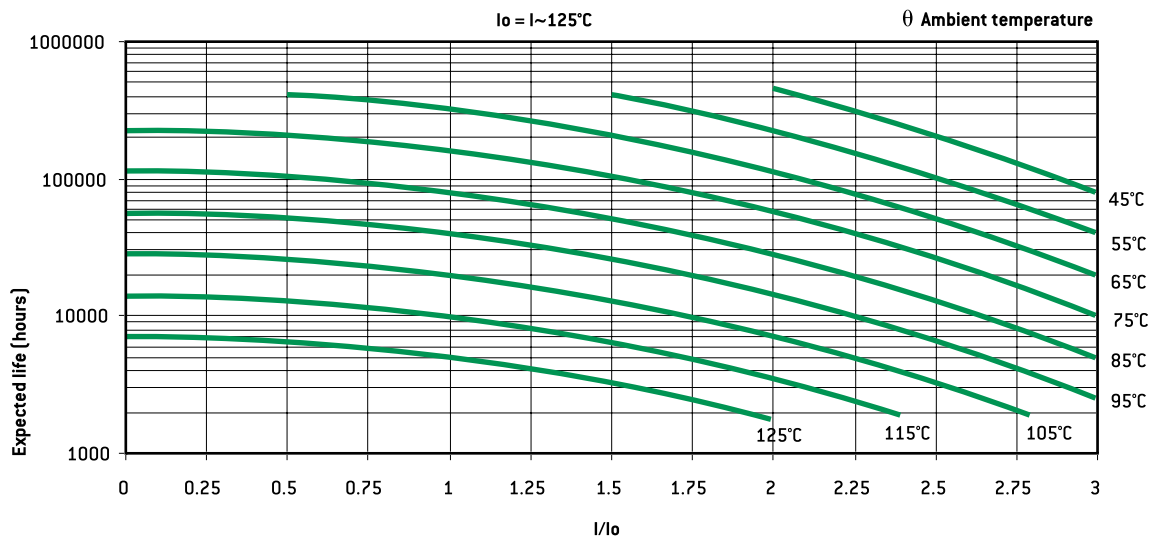
For $\varnothing = 6,5$ mm half life time values are applicable.

General technical data

1. BASIC CONSTRUCTION

Structure of an electrolytic aluminum capacitor is shown hereunder :

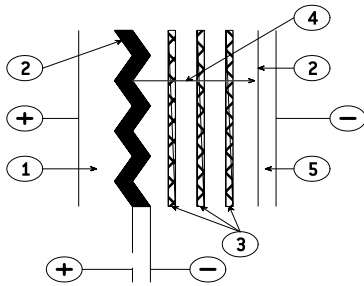

1. Anode : aluminum foil
2. Dielectric : aluminum oxide
3. Papers spacers impregnated with electrolyte
4. Ionic conduction assumed by electrolyte
5. Cathode : aluminum foil

The positive plate is an etched aluminum foil covered with alumina which is the dielectric of the capacitor.

The negative plate is constituted by a second aluminum foil which serves as a current supply, and by electrolyte-impregnated papers layers.

The metal used for anode is a $\geq 99,98\%$ grade aluminum.

The dielectric has a thickness of $13 \text{ \AA} / \text{V}$.

The aluminum used for the cathode is a $\geq 98\%$ grade aluminum covered with a dielectric layer with a thickness of about 40 \AA .

2. DIAGRAM OF THE EQUIVALENT CIRCUIT

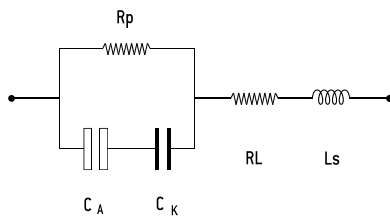

- C_A = Capacitance of the anode
 C_K = Capacitance of the cathode
 R_p = Parallel resistance due to the aluminum oxide film.
 R_L = Series resistance of connections, plates and impregnated spacer.
 L_s = Inductance of winding and connections.

A standard simplified diagram is.

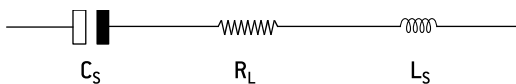

C_s is the series capacitance of both anode and cathode capacitances. Electrolytic aluminum capacitors are naturally polarized because of the insulating film on the anode. Given the very thin aluminum oxide layer, a reversed voltage should not exceed 1.5 V when there is energy supply.

Short duration reverse voltages can be absorbed by special construction, second anode replacing the former cathode.

3. CAPACITORS MARKING

3.1. ARTICLE CODE (ON EACH PACKAGING)

A followed by 6 figures number. First 3 positions are specific of the range. (Ex. A 745xxx for a FELSIC 85 BD)

140	FELSIC en batterie / in bank	741	FELSIC 125 FRS BD (ex 731)
701	PRORELSIC 125	742	PRORELSIC 105 TFRS
703	PRORELSIC 125	743	PRORELSIC 105 TFRS
704	SNAPSIC	744	FELSIC 85 BC / FELSIC 85 LP
705	SNAPSIC 105	745	FELSIC 85 BD
706	FELSIC HP BC – BD	746	FELSIC 85 M BC
708	PRORELSIC 145	747	FELSIC 85 M BD
710	CUBISIC	748	SICAL CO 42 - SICAL
711	PROMISIC 031	749	SICAL CO 42 - SICAL
712	CUBISIC LP	750	CUBISIC 125
713	SNAPSIC 105 LP	756	FELSIC 105 BC / FELSIC 105 LP
714	SNAPSIC 4P	757	FELSIC 105 BD
715	SNAPSIC 105 4P	760	FELSIC CAPAX BC
716	SNAPSIC HV	761	FELSIC CAPAX BD
717	SNAPSIC CAPAX	762	FELSIC 105 TFRS BC
718	SNAPSIC 125	763	FELSIC 105 TFRS BD
721	RELSIC 033	764	FELSIC HV BC
722	CI FRS	765	FELSIC HV BD
723	CI FRS	775	VACSIC
728	FELSIC 039 (ex 727) - FELSIC DI	774	VACSIC 150
738	FELSIC 037 (ex 737)	776	ALSIC 20G / ALSIC 145 20G
740	FELSIC 125 FRS BC (ex 731)		

In FELSIC ranges, article code without first letter A, is printed on each capacitor. a Figure 9 in fourth position shows a special product.

3.2. BATCH (ON EACH CAPACITOR).

3 figures or 6 figures

3.3. DATE (ON EACH CAPACITOR IF APPLICABLE)

4 figures (year-week)

4. ELECTRICAL CHARACTERISTICS

4.1. RATED CAPACITANCE C_R

The rated capacitance is defined at 100 Hz and at ambient temperature.

4.2. RATED VOLTAGE U_R

U_R is the maximum DC voltage which may be applied in continuous operation. When applying a superimposed alternating voltage, the peak value of the resulting waveform should not exceed the rated voltage.

4.3. PEAK VOLTAGE U_p

U_p is the maximum repetitive voltage which can be applied within short periods. Defined in CECC 30 300 and IEC 60 384-4 :

1000 cycles of 30 s charge followed by a no load period of 5 min. 30 s with upper category temperature.

$$U_p \geq 1,15 U_R \quad (U_R \leq 315 \text{ V})$$

$$U_p \geq 1,10 U_R \quad (U_R > 315 \text{ V})$$

General technical data

4.4. DISSIPATION FACTOR TANδ

The dissipation or loss factor is defined by its tangent $\text{Tan}\delta$

$$\text{Tg}\delta = R_s C_s \omega$$

$$(\omega = 2\pi F)$$

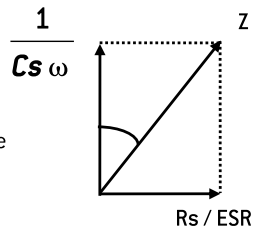

ESR Capacitor Equivalent Series Resistance

Cs Capacitor capacitance

F Frequency [100 Hz]

Z Capacitor impedance

4.5. EQUIVALENT SERIES RESISTANCE ESR

The relation between ESR and dissipation factor $\text{Tan}\delta$ is given in § 4.4.

4.6. IMPEDANCE Z - INDUCTANCE L

The impedance is given by :

$$Z = \sqrt{R^2 + \left(L\omega - \frac{1}{C\omega}\right)^2}$$

L inductance. Generally L = 5 to 20 nH

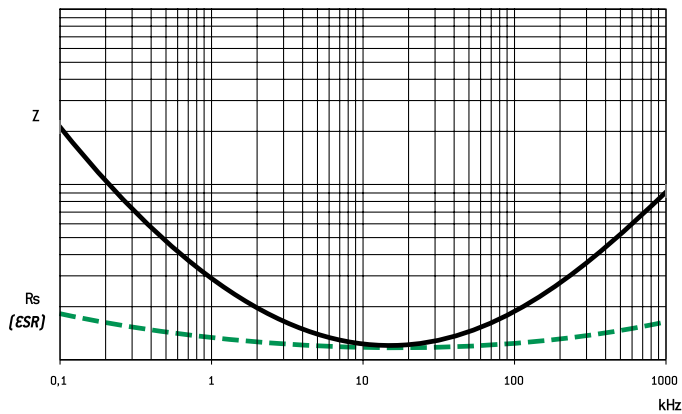

Z and ESR as function of frequency typically follows the chart :

4.7. PERMISSIBLE RIPPLE CURRENT (I r.m.s.) I~

The current is defined at the maximum climatic category and at 100 Hz. It is the root mean square value r.m.s. The value I_0 is the rated value for calculations of expected life up to $3 I_0$.

4.8. LEAKAGE CURRENT II

It is measured at 20°C after a 5 min. polarization under rated voltage.

For C_R in μF and U_R in V :

$$I \leq 0,01 C_R U_R \text{ or } 1 \mu\text{A}^*$$

when $C_R U_R \leq 1000 \mu\text{C}$

$$I \leq 0,006 C_R U_R + 4 \mu\text{A}$$

when $C_R U_R > 1000 \mu\text{C}$

For $U_R > 350 \text{ V}_{\text{DC}}$ it can be specified :

with $K = 4, 6 \text{ or } 8$

or

$$I \leq 0,3 (C_R U_R)^{0,7} + 4 \mu\text{A} \text{ (CECC 30 300)}$$

* Whichever is the greater

4.9. CHARACTERISTICS

Versus temperature (typical values).

4.9.1. Capacitance drift

Versus temperature

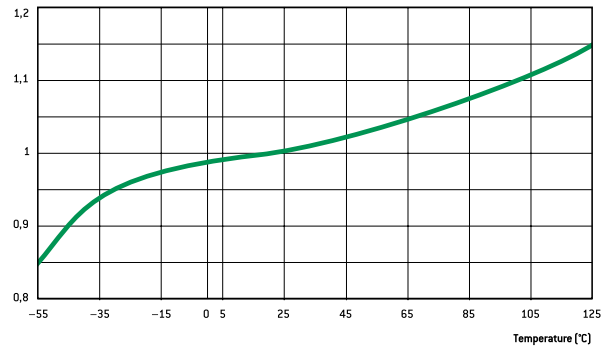

4.9.2. ESR and Z drifts at 100 Hz

Versus temperature

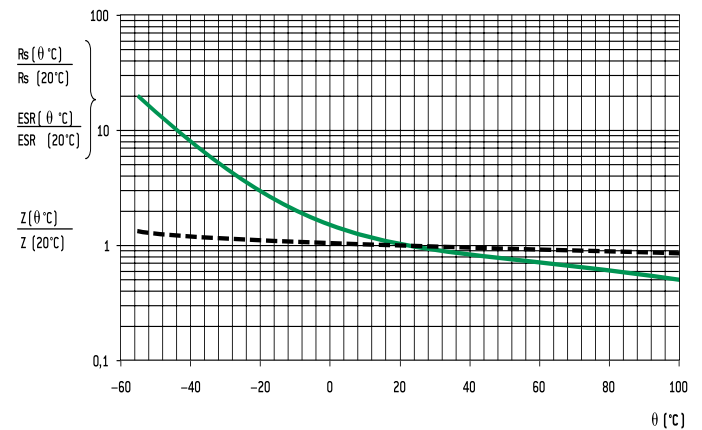

4.9.3 Leakage current drift

Versus temperature

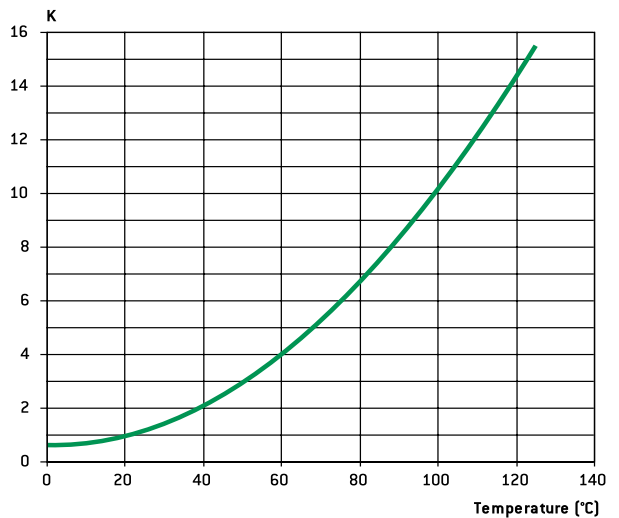

General technical data

5. SPECIFICATION TO APPLY

Electrolytic aluminum capacitors are defined in :

- NF and UTE French national standard
- CECC European specifications
- IEC international specifications

Quality insurance procedures are described in these specifications.

	French	European	International
Generic specification Fixed capacitors	NF C 83 100	CECC 30 000 EN 130 000	IEC 60 384 -1 QC 300 000
Sectional specification Electrolytic aluminum capacitors	NF C 83 110	CECC 30 300	IEC 60 384 - 4 C 300 300
Blank deta II specification - Electrolytic aluminum capacitors with non solid electrolyte /	UTE 83 110	CECC 30 301	IEC 60 384 - 4 -1 QC 300 301
Blank deta II specifications	CECC 30 301- 017 to CECC 30 301- 062 CO 31 to CO 55	CECC 30 301- 017 to CECC 30 301- 062 CECC 30 301- 802 to CECC 30 301- 811	

6. ENDURANCE TESTS / LIFE TIME

6.1. STANDARD ENDURANCE TEST

at max category temperature :

Temperature	Endurance test			
	Grade I - Long life			Grade II - General purpose
	10 000 h	5 000 h	2 000 h	1 000 h
125°C			•	
105°C		•	•	•
85°C	•	•	•	•

Standard endurance tests do not exceed 2000 hours at 125°C. However, present EXXELIA^{SIC SAFCO} technologies concerning liquid electrolytes have led to endurance tests up to 5000 hours at 125°C (PRORELSIC 125 - FELSIC 125 RS) and even 20000 hours at 125°C (PRORELSIC 145 - ALSIC 145)

6.2. PERFORMANCE REQUIREMENTS ON STANDARD ENDURANCE TESTS.

Permissible capacitance drift $\Delta C/C$ (%)

Permissible increase factors on $\tan\delta$, ESR, Z and II initial values

U_R	Endurance test			
	Grade I			Grade II
	10 000 h	5 000 h	2 000 h	1 000 h
6,3 V			+15 -30	+25 -40
10 V - 35 V	+15 -20	± 15	± 15	± 30
40 V - 160 V	± 15	± 15	± 15	± 30
> 160 V	± 15	± 10	± 10	± 15

	Endurance test			
	Grade I			Grade II
	10 000 h	5 000 h	2 000 h	1 000 h
$\tan\delta$ or ESR (1)	1,5	1,3	1,3	1,5
Z (2)	3	2	2	3
II	Standard values			

(1) $\tan\delta$ or ESR : for initial value, take standard value.

(2) Z : for initial value, take specified value (see data sheet).

Specific requirements can be taken into consideration with regards to initial values of dissipation factor or equivalent series resistance and impedance.

6.3. FAILURE CRITERIA FOR ELECTROLYTIC CAPACITORS.

Failure criteria are defined in CECC 30 301

- Non measurable defaults leading to complete failure.
- Measurable defaults leading to adjustment losses of the load circuit (failure due to variations).

6.3.1. Non measurable defaults.

They might be summed up as :

- Open circuit
- Short circuit
- Operation of pressure relief device
- Severely damaged insulation
- Unusable terminations

6.3.2. Measurable defaults.

Variations exceeding the values given below characterize a default.

- Capacitance drift $\Delta C/C$ (%) : 3 times the limit for standard endurance testing or 50 % (whichever is the smallest).
- $\tan\delta$ or ESR : 3 times standard max initial values.
- Z : 3 times standard max initial values.
- II : initial limit (under load conditions).

Specific requirements can be taken into consideration with regards to lower drifts.

6.4. INFLUENCE OF MAIN PARAMETER ON OPERATIONAL LIFE.

6.4.1. Temperature.

The capacitors operational life is highly dependent upon its internal temperature Θ_i and therefore upon the ambient temperature and the ripple current.

Knowing ESR and dissipated power values (§ 6.4.3.) one can figure out, the internal temperature rise and then determine the capacitors expected life.

With present high boiling point electrolytes (§ 8.6)

$\Theta_i \text{ max} = 125 \text{ to } 185^\circ\text{C}$ depending on styles.

6.4.2. Ripple current.

The ripple current flowing through the capacitor increase the internal temperature through power dissipation.

Standards define the permissible current at 100 Hz and generally consider a temperature rise of 5 to 10°C of max category temperature.

Current waveforms and frequencies make it difficult to clearly determine the capacitors internal temperature rise, which defines the operationally life.

Experiments confirm following relationship :

$$\Theta_i = \Theta_a + (\Theta_c - \Theta_a) K$$

Where :

- Θ_i = Internal hot spot temperature
- Θ_a = Ambient temperature
- Θ_c = Case temperature
- K = Parameter depending upon case diameter and cooling
 - $\Theta \geq 51 \text{ k} = 2^{\pm 0,5}$
 - $\Theta < 51 \text{ k} = 1,5^{\pm 0,5}$ (air cooling - 0,2 m/s)

General technical data

r.m.s. value according to current waveform.

Function	Mean value	R.m.s. value	Function	Mean value	R.m.s. value	Function	Mean value	R.m.s. value
	$A (t_0/T)$	$A \sqrt{t_0/T}$		$A/2$	$A \sqrt{3}$		$2A/\pi$	$A / \sqrt{2}$
	$A (t_1/T)$	$A \sqrt{2t_1/3T}$		$2A/\pi (t_0/T)$	$A \sqrt{t_0/2T}$		$A/2$	$A / \sqrt{3}$
	$A/2 (t_0/T)$	$A \sqrt{t_0/3T}$		$A/2 (t_0/T)$	$A \sqrt{t_0/3T}$		0	A

6.4.3. Dissipated power versus case dimension

For calculations of ripple currents, considering an internal temperature rise of 10°C

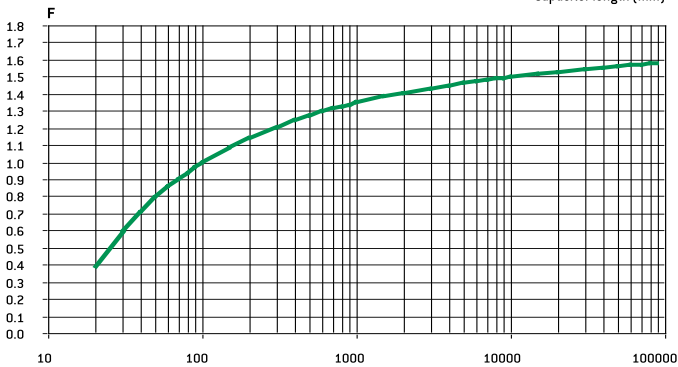
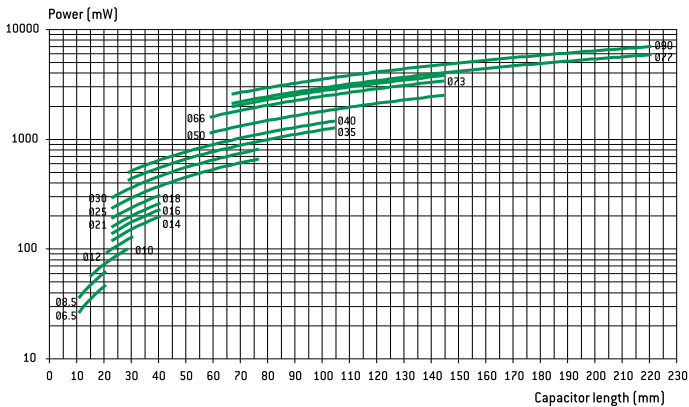

$P = ESR \cdot I^2$

P = Dissipated power (mW)

($\Theta_i - \Theta_a = 10^\circ\text{C}$)

ESR : Equivalent series resistance (100 Hz 20°C)

I : Ripple current (r.m.s. value at 100 Hz)

For different frequencies from 100 Hz, I must be multiplied by the factor F, according to above chart. :

6.4.4. Thermal resistance Rth and air cooling

Rth is static thermal resistance (without cooling) between capacitor central hot spot and ambient temperature measured at a distance of one capacitor diameter

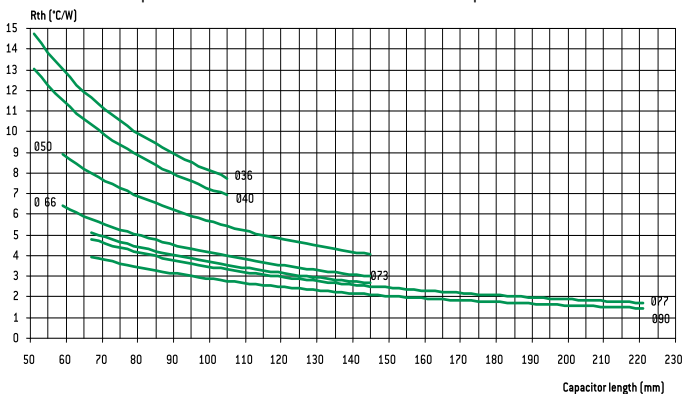

Forced or not cooling air can lead to a significant decrease of these values.

Consequently, r.m.s. ripple current can be increased as a function of air cooling speed :

\emptyset (mm)	$\leq 0,5$ m/s	1 m/s	2 m/s	3 m/s	≥ 4 m/s
66 - 90	1~	1,1 1~	1,2 1~	1,25 1~	1,3 1~
36 - 51	1~	1,2 1~	1,4 1~	1,45 1~	1,5 1~

This parameter shall be applied to one capacitor alone.

For capacitors in bank, ambient temperature must be strictly equal around all capacitors.

6.4.5. Quality guaranty

We guarantee products manufactured during 2 years from the data of shipment against defaults of material and assembly.

This guaranty can be involved by the buyer only if our products are used within normal conditions, always according to the state of the art and taking in account storage conditions.

The equipment design should take into consideration possible failures of our capacitors and related effects in order to avoid them.

Guaranty is not applicable for damages occurred by surge voltage, irregular use, polarity inversion or maintenance default.

Guaranty is exclusively limited to the replacement of individual defective capacitors within the terms of delivery. This rule applied to all cases and particularly to any further consequence of failures.

6.4.6. Reliability

Failure rate :

$$FR = \frac{\text{Number of components tested} \times \text{test duration}}{\text{Number of failures}}$$



Failure rate is measured in FIT (failure in time = 10^{-9} / hour).

The failure rate is set up during the life time of the capacitor (phase II)

I. Early failure phase (generally excluded during ageing process).

II. Operational life time of the capacitors

III. End of life

General technical data

Mean time between failures MTBF = 1/FR measured in years

Range	Failure rate for a failure percentage not exceeding 1% with a confidence level of 60 %
FELCIS 85 >350 V FELCIS CAPAX > 350 V SNAPSIC - SNAPSIC CAPAX > 350 V SNAPSIC 4P > 350 V PROMISIC 031 Ø = 6,5 SICAL CO 42 - SICAL > 350 V	50 FIT - (MTBF = 2280)
FELCIS 037 - 039 FELCIS 85 ≤ 350 V FELCIS CAPAX ≤ 350 V CUBISIC CI FRS SNAPSIC 105 - SNAPSIC 105 4P SNAPSIC 105 LP - SNAPSIC HV SNAPSIC - SNAPSIC 4P ≤ 350 V SNAPSIC CAPAX ≤ 350 V ALSIC IR - ALSIC 145 - ALSIC HV - VACSIC 150 - VACSIC SICAL CO 42 - SICAL ≤ 350 V PRORELSIC 125 Ø = 6,5 RELSIC 033 PROMISIC 031 Ø > 6,5	25 FIT - (MTBF = 4560)
FELCIS 125 FRS - SNAPSIC 125 FELCIS HV - FELCIS 105	10 FIT - (MTBF = 11410)
PRORELSIC 125 Ø > 6,5 PRORELSIC 145	5 FIT - (MTBF = 22820)

Multiplying factor of FR with voltage and temperature

Factor	Temperature [°C]							
	≤ 40	50	60	70	85	105 (1)	125 (1)	145 (1)
Factor	1	1,5	2,3	3,4	6,3	14	32	72

(1) Only for permitted capacitors

Factor	Percentage of rated voltage (2)		
	100 %	80 %	50 %
Factor	1	0,8	0,5

(2) This voltage has to be constant

Environment	Without vibration		Ground with vibrations or mob ile			
	Ground, fix Controlled air	Ground, fix	PRORELSIC SNAPSIC 20 g FELCIS 20 g	FELCIS 10 g PROMISIC SICAL Ø ≤14	CI FRS - SNAPSIC RELSIC SICAL Ø >14	ALSIC
Factor	1	2	2	4	6	12

7. MANUFACTURING FLOW CHART

Process controls

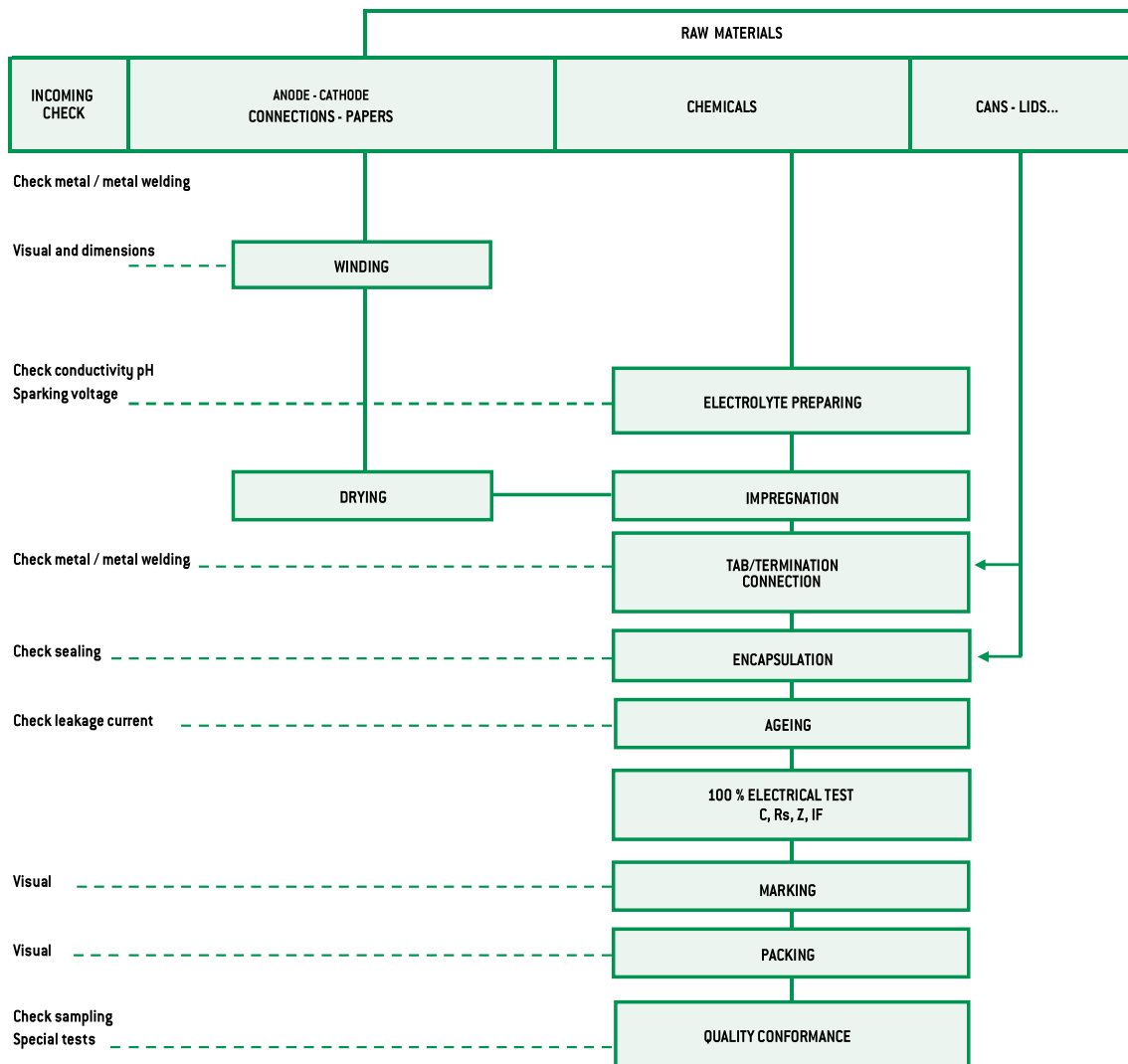

General technical data

8. INFORMATION ON APPLICATION

8.1. CLEANING SOLVENTS

Use aliphatic alcohols, such as denatured ethyl alcohol, isopropanol, or butylacetate, or else alkaline diluted solutions. Avoid incompatible solvents (halogenous for example).

8.2. SHELF LIFE

There is no electrical characteristics variation for long periods of storage except leakage current which can increase.

It is caused by chemical reactions between the dielectric alumina and the electrolyte. These reactions are reversible when switched on. Capacitors can generally be stored at temperature between -5° and $+50^{\circ}\text{C}$ without reforming for the following periods of time :

- For $U_R \leq 100\text{ V}$, storage time : 5 years
(up to 10 years under specific conditions)
- For $100\text{ V} < U_R \leq 360\text{ V}$ storage time : 3 years
- For $360\text{ V} < U_R < 500\text{ V}$ storage time : 1 year
- For $U_R \leq 500\text{ V}$, storage time : 6 months

Generally when these periods are overstepped, one hour at rated voltage causes the decrease of leakage current under the specified limits. An other way to avoid this leakage current increase problem is to always limit available power through capacitor during first seconds or minutes after storage or transport, according to the following chart :

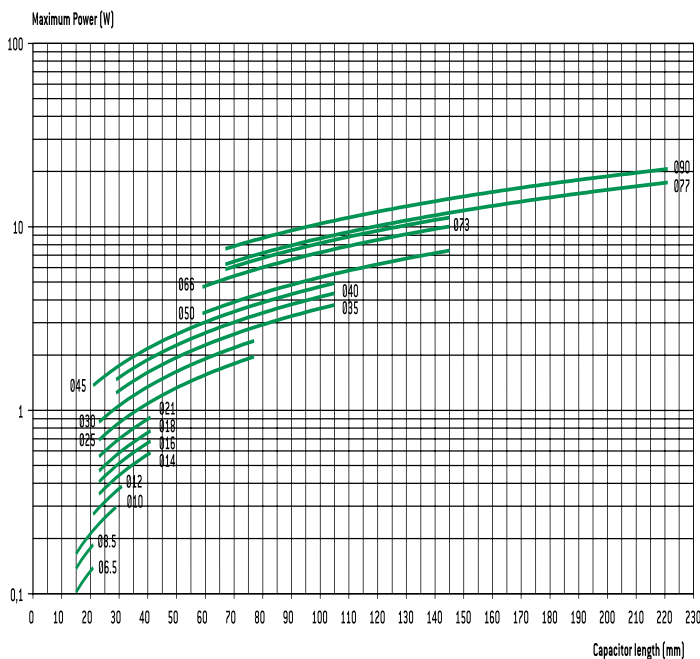

8.3. LOW PRESSURE RESISTANCE

EXXELIA^{SIC SAFCO} capacitors can be used with ambient low pressure decreasing up to 10 mbar (altitude 28000 m – 92000 feet).

8.4. MOUNTING SCREW TERMINALS CAPACITORS (FELSIC)

Capacitors may be used vertically (terminals on top) or horizontally. When used horizontally, the following position in relation to the safety vent, is recommended :

Mounting capacitors in series may be used for operating voltage exceeding U_R . See FELSIC in bank

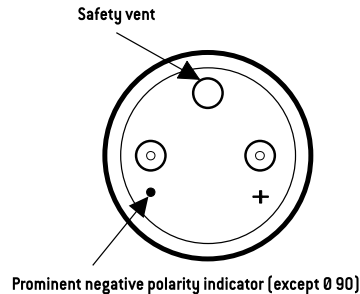

8.5. MOUNTING SOLDER TYPE CAPACITORS.

They may be used in any position. During mounting, avoid applying excessive force to capacitor pins or wires. There is a risk of damaging internal connections. After soldering and for the same reasons, do not try to move the capacitor's body.

8.6. ELECTROLYTES : SAFETY RULES.

Electrolytes used in EXXELIA^{SIC SAFCO} capacitors are manufactured by EXXELIA^{SIC SAFCO}. Main solvents are generally γ butyrolactone and ethylene glycol, very stable high boiling point solvents. Ionic conductive salts in electrolyte induce a very weak acidity (pH 5 to 7).

8.7. ENVIRONMENT.

- There is no possibility to produce gaseous emissions of nitrogen oxides or liquid emissions of nitrites or nitrates during the manufacture process.
- There is no possibility to produce liquid emissions or salts coming from dangerous metals such as mercury, hexavalent chromium or cadmium and from poisons such as arsenic or cyanides.

Accessories not made in aluminum, ring, screw, are also plated in anticorrosion processes without cadmium.

EXXELIA^{SIC SAFCO} is always involved in this security field particularly in using whenever it's possible chemicals for electrolyte, without well-known risks.

- Dimethylformamide (DMF) dangerous solvent forbidden in several uses is completely excluded by EXXELIA^{SIC SAFCO}, since 1990.
- There is no halogen compound such as chlorofluorocarbon (CFC or FCKW in german) or polychlorobiphenyl (PCB-Pyralene) or pentabromodiphenylether or octabromodiphenylether.

There is neither benzene, toluene or phenyl compound nor explosive such as picric acid, nor asbestos in plastic covers.

All the capacitors made by EXXELIA^{SIC SAFCO} since 1991, can be scrapped or used in raw materials recycling processes with-out special care.

EXXELIA^{SIC SAFCO} aluminum capacitors with non solid electrolyte are particularly suitable for different kinds of environment taking in account severity increasing laws.

European directives 2003/11/EC, 2002/96/EC (WEEE) and 2002/95/EC (RoHS) applies to all EXXELIA^{SIC SAFCO} capacitors including every solder type, manufactured with pure tin coated pins or wires, since at least January 2006.

EXXELIA^{SIC SAFCO} capacitors do not contain any carcinogen, mutagen and substance toxic for reproduction in accordance with 1907/2006/EC (REACH) European directive target.

Mounting and insulating parts

STUD FIXING : FELSIC BD

Steel nut, spring washer and insulating washer are delivered loosely with the capacitor.

STANDARD MOUNTING WITH :

Insulating washer and steel nut

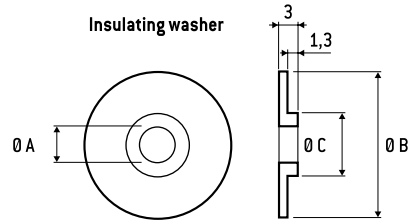
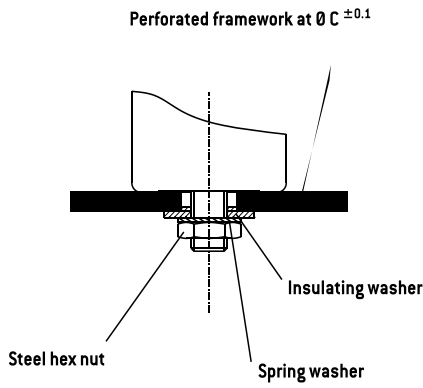

Ø Capacitor	Dimension (mm)				Code
	M	Ø A	Ø B	Ø C	
36	8	8,4	25	18,5	A 691060
51 - 77	12	12,5	30	21,5	A 691061
90	12	12,5	35	21,5	A 691062

Insulating plastic nut with or without insulating washer

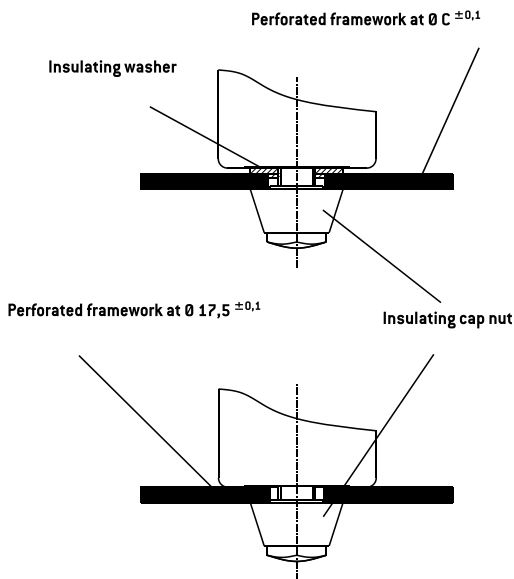

Insulating cap nut

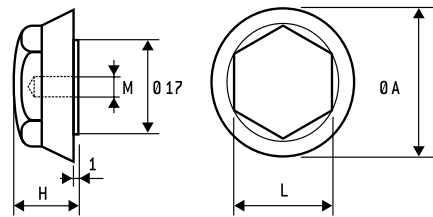

M	Dimension (mm)				Max. torque	Code
	Ø A	H	L			
8	25	15	17	3 Nm	A 691070	
12	30	20	19	7 Nm	A 691071	

Ring - clip mounting : FELSIC LP

Ring clips shall be ordered separately.

Tightening screws and nuts are supplied loosely.

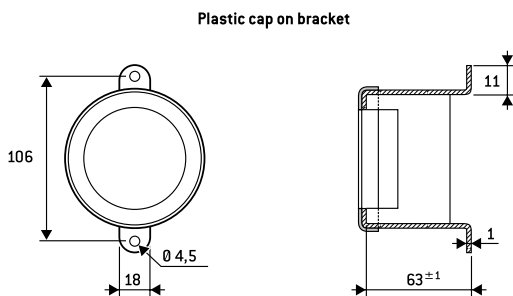

FELSIC 85 LP FELSIC 105 LP	Code
Metal bracket	A691055
Plastic cap	A691065

General technical data

Ring - clip mounting : FELSIC BC

Ring clips shall be ordered separately.

Tightening screws and nuts are supplied loosely.

FELSIC BC - Metal ring-clips

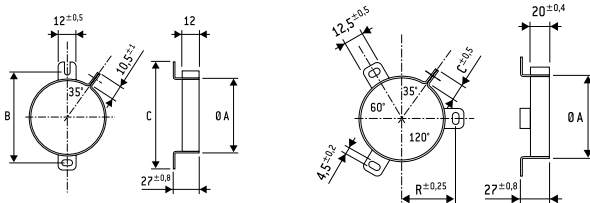

Ø A Cap.	B	C	Code	Ø A Cap.	B	C	Code
36	54	63	A 691901	51	33,5	11,8	A 691905
				66	39	10,5	A 691913
				73	44	10,5	A 691914
				77	44,5	10,5	A 691907
				90	53,3	11,8	A 691915

Stirrup mounting : CUBISIC LP

Stirrups shall be ordered separately.

Tightening screws and nuts are supplied loosely

Salt mist endurance of screws and mounting accessories :
minimum 96 h (IEC 600 68-2-11)

CUBISIC /CUBISIC LP - Metal bracket

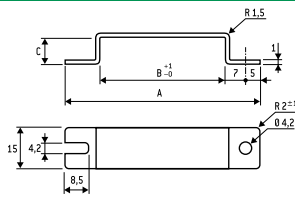

Ø A Cap.	A	B	C	Code
45x12	69	45	10	A 691057
35x16	59	35	14	A 691059

PACKAGING

1. PACKAGING AND WEIGHT UNITS.

1.1. Capacitor with screw terminals

Case dimensions				Unit weight *
Ø	H			(g)
36	47	52	53	70
36	60			79
36	80	81		100
36	104	105		120
51	47			80
51	62	63		105
51	81	82		190
51	104	105		260
51	112			270
51	144			370
66	104	105		430
66	112			460
73	104	112		600
73	144			680
77	104	105		620
77	144	145		860
77	200			1300
77	220	221		1400
90	67			600
90	144	145		1400
90	200			1800

* Unit weight = typical values

Possible variations of = ± 25 % according to different voltage and capacitance.

1.2. Radial solder types

Case dimensions		ALSIC	SNAPSIC	Case dimensions		ALSIC	SNAPSIC
Ø (mm)	H (mm)	Weight* (g)	Weight* (g)	Ø (mm)	H (mm)	Weight* (g)	Weight* (g)
10	16	1,8		35	30		50
				35	40		50
12,5	21	4,5		35	45		52
12,5	24	5		35	50		60
				35	75		95
16	25	8,2		35	100		125
22	25		15	40	40		65
22	30		17	40	50		100
22	40		18	40	75		130
				40	100		170
25	25		17	45	21		50
25	30		20	45	25		60
25	35		22	45	30		73
25	40		25	45	35		85
25	45		28	45	45		110
25	50		30	45	75		180
				45	100		240
30	25		28				
30	30		30				
30	35		30				
30	40		40				
30	45		45				
30	50		50				

Case dimensions			CUBISIC
I	L	H	weight (g)
35	35	16	30
35	50	16	40
45	35	12	30
45	50	12	45
45	75	12	60

* Unit weight = typical values

Possible variations of = ± 25 % according to different voltage and capacitance.

1.3. Axial types

Case dimensions		PRORELSIC	PRORELSIC	SICAL CO 42
Ø (mm)	H (mm)	Unit weight * (g)	PROMISIC (g)	SICAL (g)
6,5	15		1,6	
6,5	19		1,8	1,8
8,5	19		2,3	2,3
10	19		2,8	2,8
10	25		3,5	3,5
10	28		3,8	
12	25		5	
12	30		5,4	5,4
14	30		6,9	6,9
14	41		9,5	
16	30	7,7		7,7
18	35	13,6		
18	40	15,3		15,3
21	40	19,5		19,5
25	40	28		28
25	50	35		35
25	75	56		56

* Unit weight = typical values

Possible variations of = ± 25 % according to different voltage and capacitance.

General technical data

2. PACKAGING ON TAPE

2.1. Axial types

Dimensions and tolerance (in mm) in accordance with IEC 60 286-1

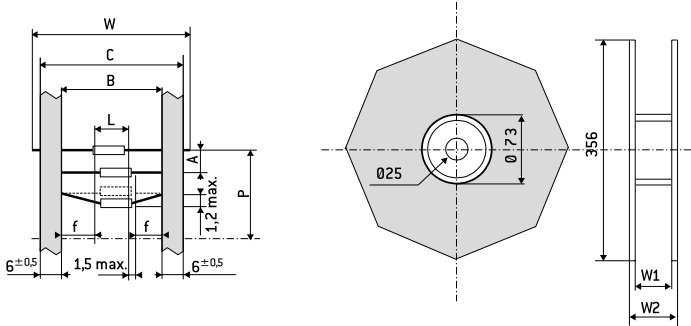

Dimensions									
D	L max.	B	A	P	C max.	W ₁	W ₂ max.	W	n ⁽²⁾
6,5	20	73±1,5	10±1,5	± 2	87,5	93	106	85±1,5	1000
8,5 ⁽¹⁾									750
10 ⁽¹⁾									400
12 ⁽¹⁾	32	73±1,5	15±1,5	± 3	87,5	93	106	85±1,5	400
14 ⁽¹⁾									200

- (1) On tape only on request
- (2) n = number of capacitors per reel.

White positive tape f : > 20 mm
P: 10 space

2.2. ALSIC IR - ALSIC 145

Dimensions and tolerance (in mm) in accordance with IEC 60 286-2.

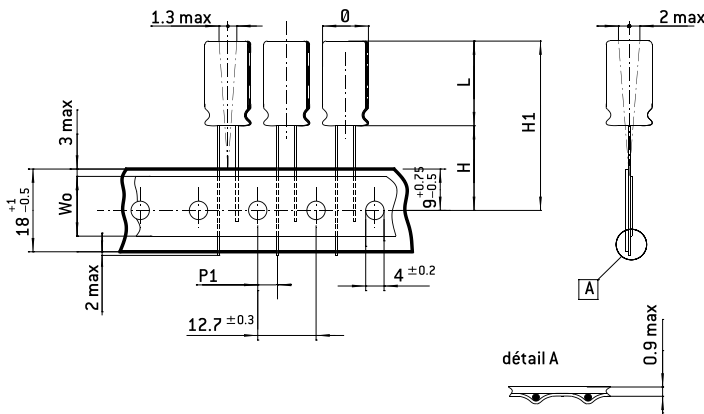

Dimensions (mm)					
Ø	L	H ₁ max.	W ₀	P ₁	H
10	16	46,5	13	3,85	19±1

Fan fold packaging (Ammopack)
Number of capacitors : 1000

