

# PRELIMINARY DATASHEET

## CGY2139AUH/C2 8-12 GHz 41dBm Power Amplifier

### DESCRIPTION

The CGY2139AUH/C2 is a high performance dual line-up 3 stages GaAs Power Amplifier MMIC designed to operate in the X band.

The CGY2139AUH/C2 has an output power of 12 W at the 1dB compression point and has a small signal gain of 25 dB. It can be used in X-band Radars, Telecommunication and Instrumentation applications.

The MMIC uses gold bonding pads and backside metallization and is fully protected with Silicon Nitride passivation to obtain the highest level of reliability.

The MMIC power dissipation is limited by the die thermal resistance, it has been designed to work in pulse mode, The CGY2139AUH/C2 can be operated at a duty cycle as high as 50%. Drain switch mode is the preferred control mode.

Cascading CGY2139PUH/C1 or CGY2139MUH/C1 with CGY2139AUH/C2 can form a 40dB gain 12W X-band pulse mode amplifier chain.

### APPLICATIONS

- ▶ Radar
- ▶ Telecommunications
- ▶ Instrumentation

### FEATURES

- ▶ Operating Range : 8 GHz to 12 GHz
- ▶ Output  $P_{\text{sat}}$  : 41.2 dBm
- ▶ Output  $P_{1\text{dB}}$  : 41 dBm
- ▶ Gain : 25 dB
- ▶ 50 Ohms input and output matched
- ▶ Input Return Loss : > 10 dB
- ▶ Output Return Loss : > 10 dB
- ▶ Power Supply : 4.2 A at VDD = 8.5 V
- ▶ Die size = 4.5 x 4.1 x 0.1 mm
- ▶ Device Availability (Q3 2013) :
  - Tested, Inspected Known Good Die (KGD)
  - Connectorized evaluation solution

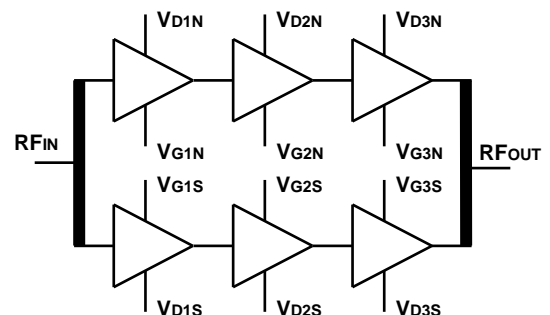

CGY2139AUH/C2 Power Amplifier Block Diagram



## MAXIMUM VALUES

Symbol	Parameter	Conditions	MIN.	MAX.	UNIT
$V_{G1N}, V_{G2N}, V_{G3N}, V_{G1S}, V_{G2S}, V_{G3S}$	Gate voltage		- 2,5	0	V
$V_{D1N}, V_{D2N}, V_{D3N}, V_{D1S}, V_{D2S}, V_{D3S}$	Drain voltage		0	+ 9	V
$I_{D1N}, I_{D1S}$	Drain current			200	mA
$I_{D2N}, I_{D2S}$				600	
$I_{D3N}, I_{D3S}$				1800	
$I_{GNN, s}$ (all gates)	Gate Current		- 10	+ 10	mA
$P_{IN}$	RF Input power			+ 23	dBm
$T_{amb}$	Ambient temperature		- 40	+ 85	°C
$T_j$	Junction temperature			+ 150	°C
$T_{stg}$	Storage temperature		- 55	+ 85	°C

Operation of this device outside the parameter ranges given above may cause permanent damage

## THERMAL CHARACTERISTICS

Symbol	Parameter	Value	UNIT
$R_{th(j-amb)}$	Thermal resistance from junction to ambient (DC power at $T_{amb}$ max)	TBD	°C/W

## ELECTRICAL CHARACTERISTICS

Conditions :  $T_{amb} = + 25$  °C,  $I_{DQ3N}, I_{DQ3S} = 1400$ mA,  $I_{DQ2N}, I_{DQ2S} = 400$ mA,  $I_{DQ1N}, I_{DQ1S} = 125$ mA, 10% duty cycle

Symbol	Parameter	Conditions	MIN.	TYP.	MAX.	UNIT
RFin	Input frequency		8		12	GHz
<i>Performances on Reference Board at <math>f_i = 10</math> GHz, Drain voltage 8.5V (gate voltage -0.7V)</i>						
$V_{D1N, 2N, 3N}, V_{D1S, 2S, 3S}$	Drain Supply voltage				8.5	V
$I_{DD}$	Total supply current @ Psat	Drain voltage 8.5V		4.3	5.0	A
G	Gain		22	25		dB
NF	Noise Figure			TBD		dB
P1dB	1dB compression point			41		dBm
Psat	Saturated power			41.2		dBm
PAE	Power Added Efficiency			36		%
OIP3	Output third order intercept point			50		dBm
IMD3	2 Carriers 3 dB below P1dB			TBD		dBc
$ISO_{rev}$	Reverse Isolation	RFOUT/RFIN		TBD		dB
$S_{11}$	Input reflection coefficient	50 Ohms		-10		dB
$S_{22}$	Output reflection coefficient	50 Ohms		-10		dB
$P_{OFF}$	Leakage when HPA off All gates = -2,5V	RFIN = + 20 dBm		TBD		dBm

(\*) Measurement reference planes are the INPUT and OUTPUT plans of the CGY2139AUH/C2 MMIC.



**Caution** : This device is a high performance RF component and can be damaged by inappropriate handling. Standard ESD precautions should be followed. OMMIC document "OM-CI-MV/ 001/ PG" contains more information on the precautions to take.

CGY2139AUH/C2 can only be measured on-wafer using a pulse measurement test-bench, this method assure a full polarization conditions and cold channel temperature, this method also remove the risk of reliability damages due to high temperature overstress inherent to on wafer measurements at full polarization and reflects the performances of the devices in good cooling conditions.

## OUTPUT POWER, GAIN AND PAE

Conditions: On Carrier measurements with 50 Ohms probes

$V_{D3N}, V_{D3S} = V_{D2N}, V_{D2S} = V_{D1N}, V_{D1S} = 8.5V$ ,  $V_{G3N}, V_{G3S} = V_{G2N}, V_{G2S} = V_{G1N}, V_{G1S} = -0.7V$ ,  $(I_{DQ3N} + I_{DQ3S} + I_{DQ2N} + I_{DQ2S} + I_{DQ1N} + I_{DQ1S}) = 3800 \text{ mA}$ , duty cycle 10%,  $T_{amb} = + 25^{\circ}\text{C}$

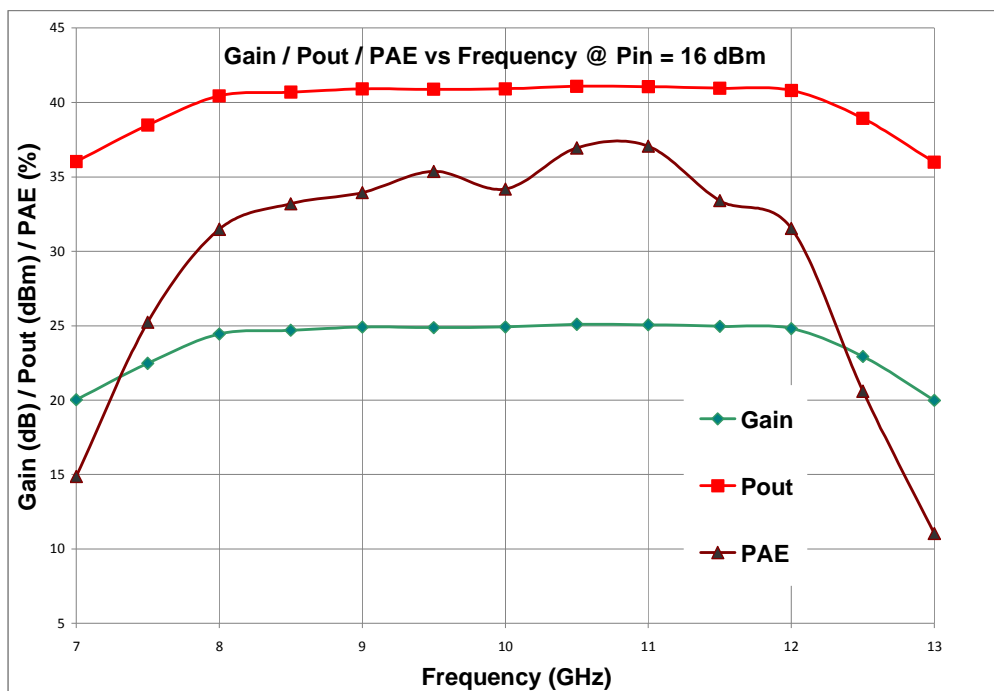

Gain, Pout and PAE vs frequency

Note : Input power at 16dBm is near P1dB compression point.

Conditions: On Carrier measurements with 50 Ohms probes

$V_{D3N}, V_{D3S} = V_{D2N}, V_{D2S} = V_{D1N}, V_{D1S} = 8.0V$ ,  $V_{G3N}, V_{G3S} = V_{G2N}, V_{G2S} = V_{G1N}, V_{G1S} = -0.7V$ ,  $(I_{DQ3N} + I_{DQ3S} + I_{DQ2N} + I_{DQ2S} + I_{DQ1N} + I_{DQ1S} = 3800 \text{ mA}$ , duty cycle 10%,  $T_{amb} = + 25^{\circ}\text{C}$

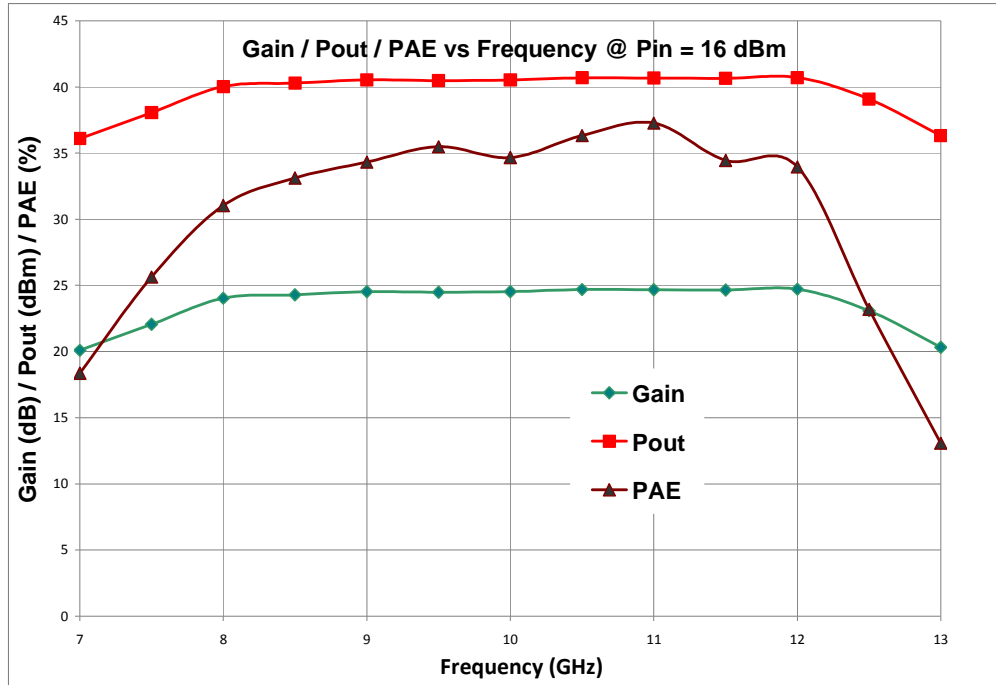

**Gain, Pout and PAE vs Frequency**

Conditions: On Carrier measurements with 50 Ohms probes

$V_{D3N}, V_{D3S} = V_{D2N}, V_{D2S} = V_{D1N}, V_{D1S} = 7.5V$ ,  $V_{G3N}, V_{G3S} = V_{G2N}, V_{G2S} = V_{G1N}, V_{G1S} = -0.7V$ ,  $(I_{DQ3N} + I_{DQ3S} + I_{DQ2N} + I_{DQ2S} + I_{DQ1N} + I_{DQ1S} = 3800 \text{ mA}$ , duty cycle 10%,  $T_{amb} = + 25^{\circ}\text{C}$

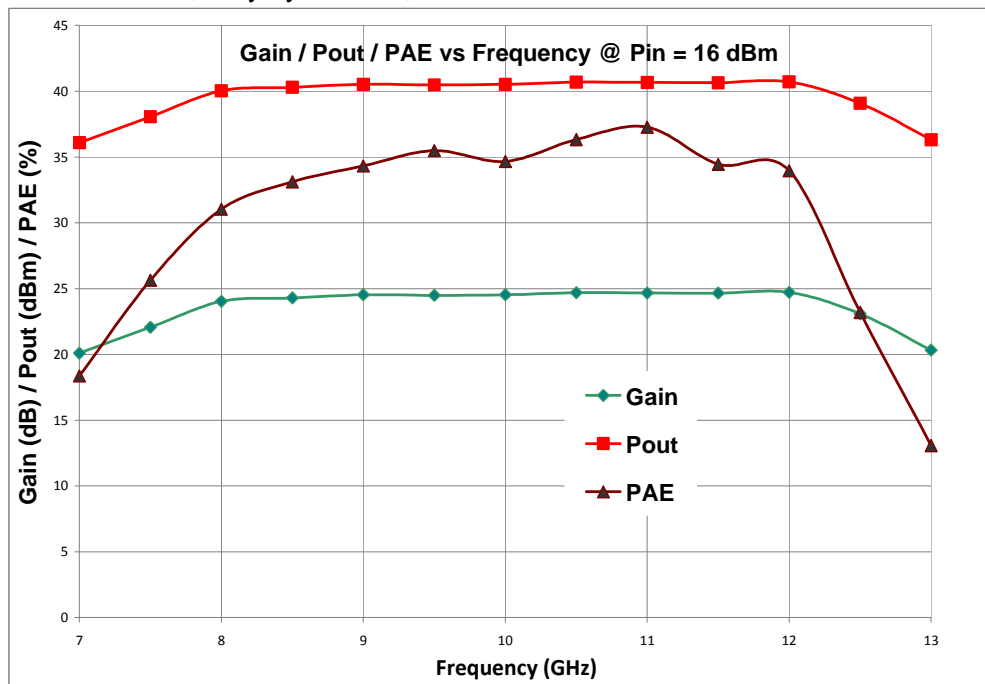

**Gain, Pout and PAE vs Frequency**

## CURRENT CONSUMPTION

Conditions: On Carrier measurements with 50 Ohms probes

$V_{D3N}, V_{D3S} = V_{D2N}, V_{D2S} = V_{D1N}, V_{D1S} = 8.5V$ ,  $V_{G3N}, V_{G3S} = V_{G2N}, V_{G2S} = V_{G1N}, V_{G1S} = -0.7V$ ,  $(I_{DQ3N} + I_{DQ3S} + I_{DQ2N} + I_{DQ2S} + I_{DQ1N} + I_{DQ1S}) = 3800\text{ mA}$ , duty cycle 10%,  $T_{amb} = +25^{\circ}\text{C}$

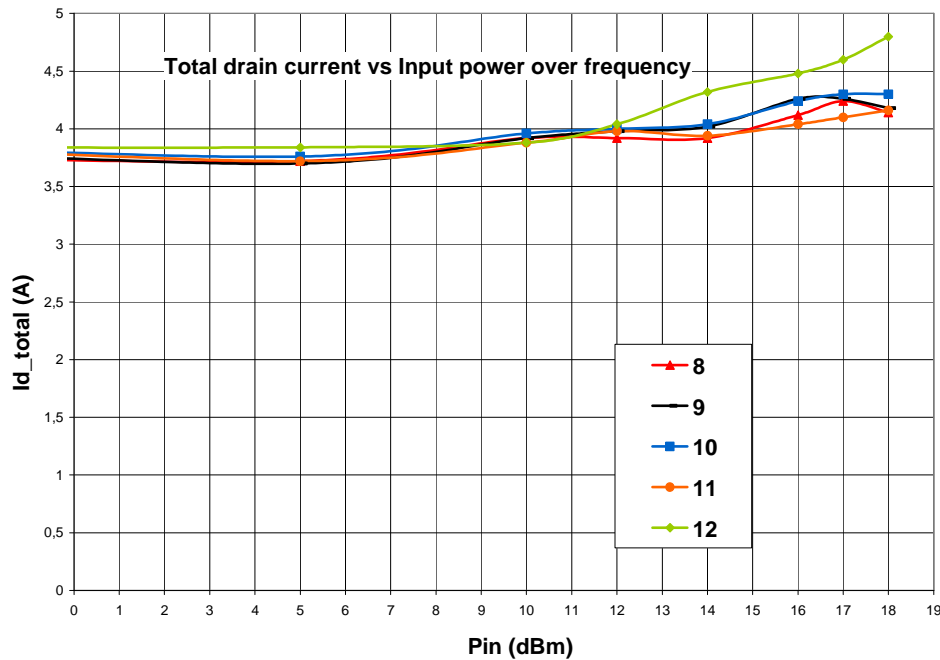

## Total current vs Input power over frequency

Conditions: On Carrier measurements with 50 Ohms probes

$V_{D3N}, V_{D3S} = V_{D2N}, V_{D2S} = V_{D1N}, V_{D1S} = 8.5V$ ,  $V_{G3N}, V_{G3S} = V_{G2N}, V_{G2S} = V_{G1N}, V_{G1S} = -0.7V$ ,  $(I_{DQ3N} + I_{DQ3S} + I_{DQ2N} + I_{DQ2S} + I_{DQ1N} + I_{DQ1S}) = 3800\text{ mA}$ , duty cycle 10%,  $T_{amb} = +25^{\circ}\text{C}$

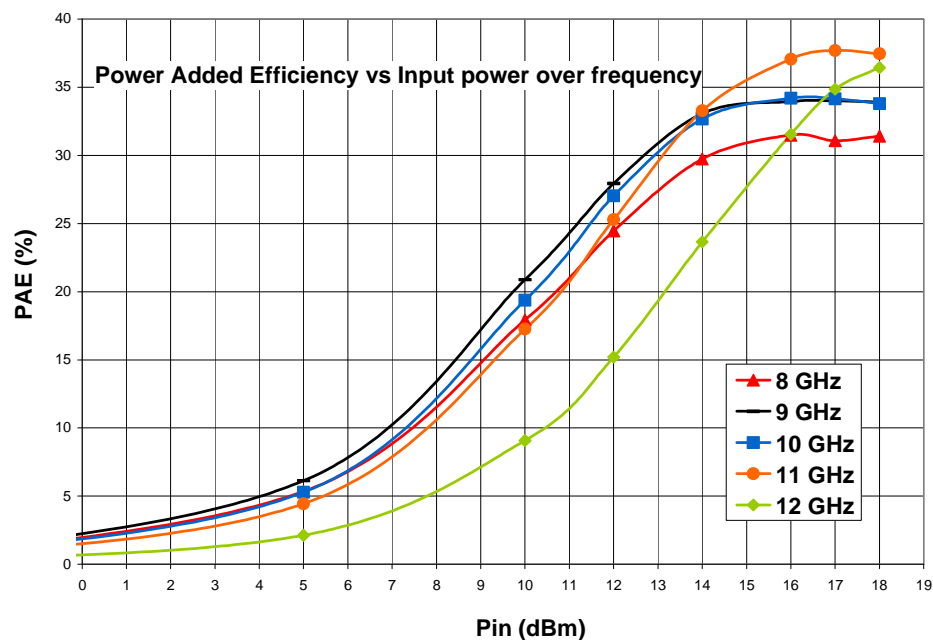

Conditions: On Carrier measurements with 50 Ohms probes

$V_{D3N}, V_{D3S} = V_{D2N}, V_{D2S} = V_{D1N}, V_{D1S} = 8.5V$ ,  $V_{G3N}, V_{G3S} = V_{G2N}, V_{G2S} = V_{G1N}, V_{G1S} = -0.7V$ ,  $(I_{DQ3N} + I_{DQ3S} + I_{DQ2N} + I_{DQ2S} + I_{DQ1N} + I_{DQ1S}) = 3800 \text{ mA}$ , duty cycle 10%,  $T_{amb} = +25^\circ\text{C}$

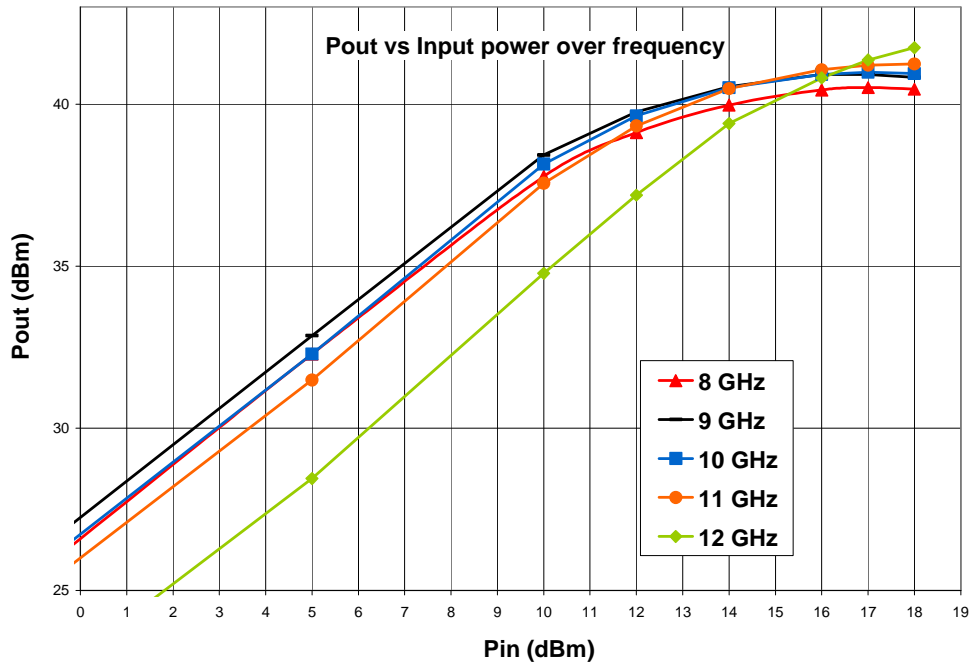

**Pout vs Input power over frequency**

## APPLICATION SCHEMATIC

Decoupling scheme depends on customer implementation, in order to prevent instability it is highly recommended to place a 47pF RF decoupling chip capacitor at each DC terminal with the shortest possible bonding wires. Additionally, a 10nF chip capacitor can be added on the drain 3 connection.

The decoupling network depends on supply, on grounding environment, on form factor, on all parasitics added by the customer environment. According to this, the appropriate network sometimes need to be fine-tuned in accordance with rules applicable in the high frequency domain.

It may also be required to add very low frequency, high capacitor value. On each drain a 10 Ohms / 10 nF RC serie network made of 0402 format capacitors have been implemented reference test-jig.

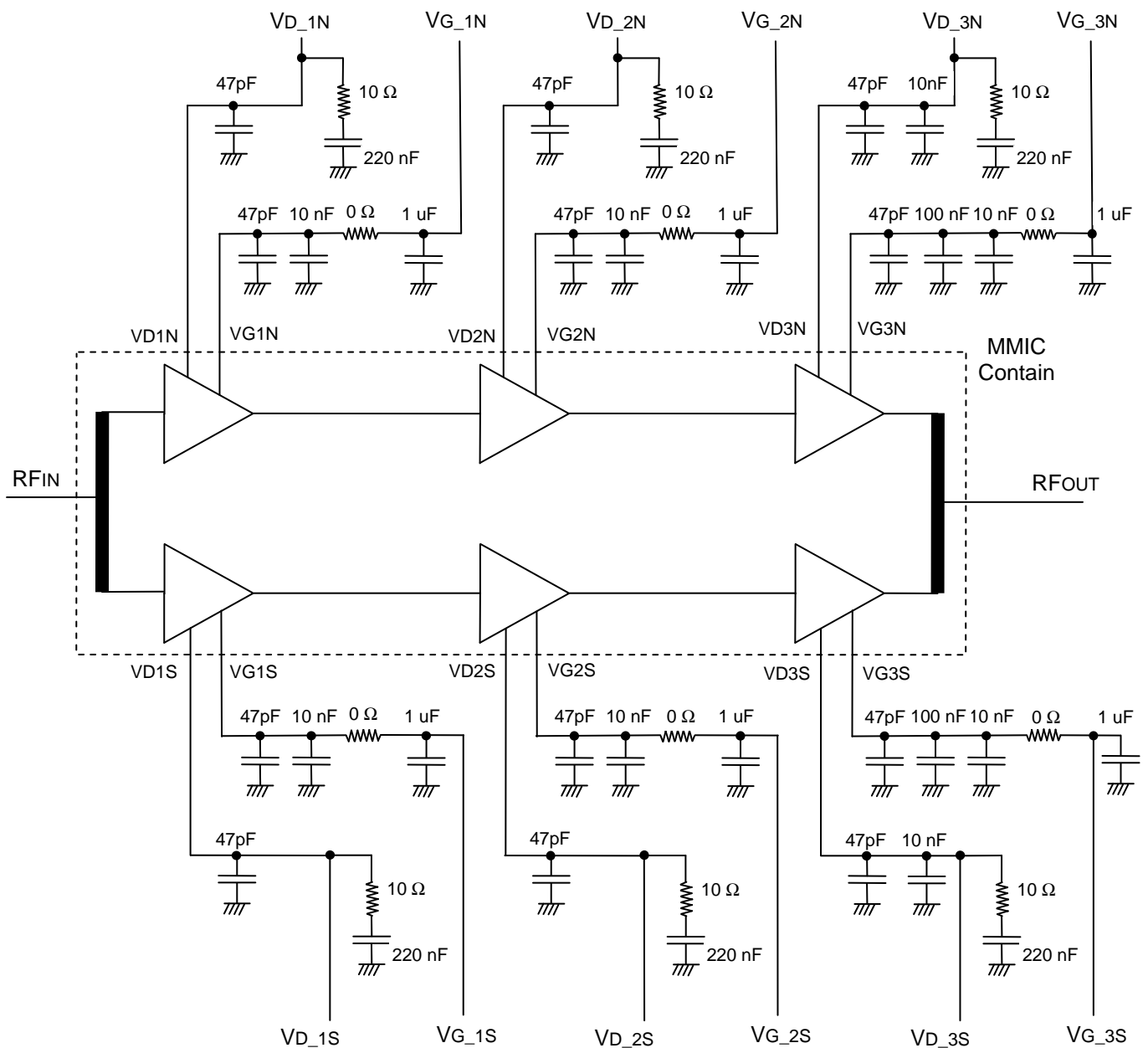

**CGY2139AUH/C2 Application schematics**

Component NAME	Value	Type	Comment
All 47pF capacitors	47pF	Chip Capacitor	Chip capacitor PRESIDIO COMPONENTS P/N SA151BX470M2HX5#013B soldered close to the die with bonding as short as possible
All 10nF capacitors	10nF	Chip Capacitor	MURATA GMA085R71C103MD01T GM260 X7R 103M 16M100 PM520

Due to the highly symmetrical design of the component and the requirements of the power combiner, it is recommended to keep the supply design as symmetrical as possible, this means  $I_{DQ1N}$  equal to  $I_{DQ1S}$ ,  $I_{DQ2N}$  equal to  $I_{DQ2S}$  and  $I_{DQ3N}$  equal to  $I_{DQ3S}$ , for the same reason, it is recommended to keep  $V_{D1N}$  equal the  $V_{D1S}$ ,  $V_{D2N}$  equal the  $V_{D2S}$  and  $V_{D3N}$  equal the  $V_{D3S}$ . It is important to keep  $V_{G1N}$  equal the  $V_{G1S}$ ,  $V_{G2N}$  equal the  $V_{G2S}$  and  $V_{G3N}$  equal the  $V_{G3S}$ .

CGY2139AUH/C2 can be supplied with only a single pulsed  $V_d$  voltage and only a single  $V_g$  voltage. Nevertheless, it is very important to keep efficient decoupling networks on drain and gates. Improper decoupling networks can lead to oscillations through supply guided feedback loop.

CGY2139AUH/C2 have been designed to present a 50 Ohms plan at the die port. 2 to 3 standard wire bondings (25um in diameter 300um in length) can be used to connect the die to the environment (microstrip or coplanar). The wire bonding terminal (alumina or PCB substrate ) should be build to compensate the inductance introduced by the wire bounding over the frequency band.

As the use of different  $V_g$  on each stage can be used to optimize a particular parameter corresponding to customer demand, all  $V_g$  are left available to the customer.

## CW OPERATIONS

CGY2139AUH/C2 doesn't support CW operation at full bias, reducing  $I_{dd}$  using gate voltage ( $V_g$ ) can be done,  $I_{dd}$  reduced by 50% can be accepted to support CW operation.



## TEST JIG

A Connecteurized test-jig have been developed, a picture is showed below.

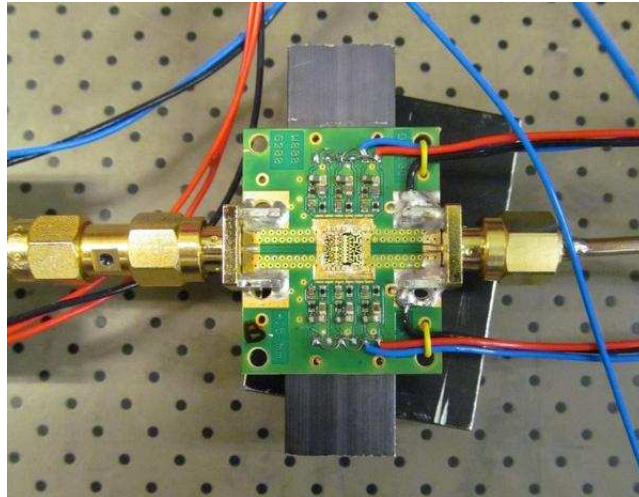

The test-jig add losses, a probe have been build to evaluate the losses : 0.7dB have been found between die plan and SMA connector at both accesses (input and output).

Due to the smal heatsink implemented, the duty cycle of the test-jig is limited to 10%. Pulse width of 10us with a pulse repetition period of 100us are recommended

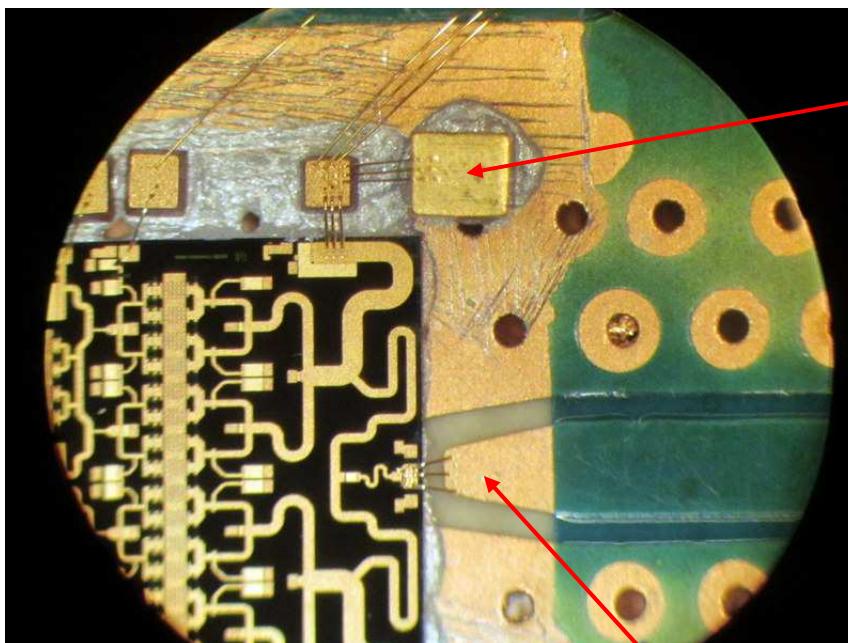

Drain 3 additional  
decoupling capacitor

3 bondings wire to connect  
coplanar wave-guide

## DIE LAYOUT AND PIN CONFIGURATION

The Die is symmetrical on the RF axis. The die positioned top view with RF input on the left and RF output on the right show DC accesses on the top labelled north (N) and DC accesses on the bottom labelled south (S).  $V_{D1N}$ ,  $V_{D2N}$ ,  $V_{D3N}$ ,  $V_{G1N}$ ,  $V_{G2N}$ ,  $V_{G3N}$  are DC signals applied on the north side,  $V_{D1S}$ ,  $V_{D2S}$ ,  $V_{D3S}$ ,  $V_{G1S}$ ,  $V_{G2S}$ ,  $V_{G3S}$  are DC signals applied on the south side. Many ground accesses are complementing the pad layout. The backside is the ground reference plan.

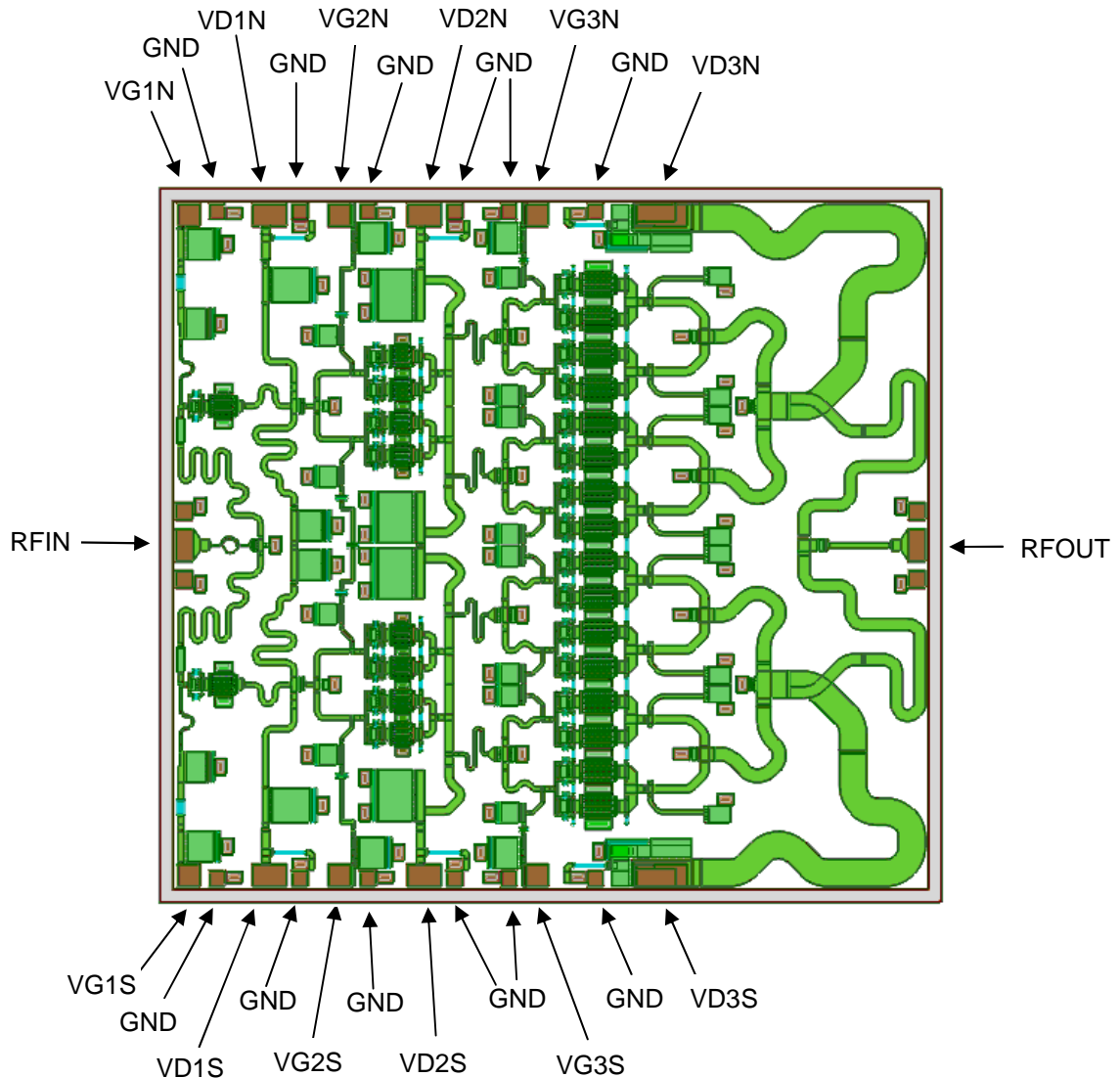

**CGY2139AUH/C2 Pad layout**

## PINOUT

The amplifier has a North face and a south face, north is top and south is bottom when RF input is on the left an RF output on the right.

Symbol	Pad	Description
RFOUT	OUT	RF output
RFIN	IN	RF input
VD1N	VD1N	First stage Drain (amplifier North)
VD2N	VD2N	Second stage Drain (amplifier North)
VD3N	VD3N	Third stage Drain (amplifier North)
VG1N	VG1N	First stage Gate (amplifier North)
VG2N	VG2N	Second stage Gate (amplifier North)
VG3N	VG3N	Third stage Gate (amplifier North)
VD1S	VD1S	First stage Drain (amplifier South)
VD2S	VD2S	Second stage Drain (amplifier South)
VD3S	VD3S	Third stage Drain (amplifier South)
VG1S	VG1S	First stage Gate (amplifier South)
VG2S	VG2S	Second stage Gate (amplifier South)
VG3S	VG3S	Third stage Gate (amplifier South)
GND	BACKSIDE	Ground

### Note :

*In order to ensure good RF performances and stability It is key to connect to the ground the pad available on the backside of the die.*

## BONDINGS PAD COORDINATES

Symbol	X coordinate (um)	Y coordinate (um)	Pad size (um x um)
GND	90	1850	Ground pad associated with RF input
RFIN	90	2050	100 x 190
GND	90	2250	Ground pad associated with RF input
VG1N	115	3995	130 x 130
GND	280	4015	90 x 90
VD1N	595	3995	200 x 130
GND	771	4015	90 x 90
VG2N	1005	3995	130 x 130

GND	1170	4015	90 x 90
VD2N	1506	3995	200 x 130
GND	1684	4015	90 x 90
GND	2005	4015	90 x 90
VG3N	2170	3995	130 x 130
GND	2522	4015	90 x 90
VD3N	2914	3995	300 x 100
GND	4410	1850	Ground pad associated with RF output
RFOUT	4410	2050	100 x 190
GND	4410	2250	Ground pad associated with RF output
GND	BACKSIDE		Ground

**CGY2139AUH/C2 Pad size and coordinates**

**BONDINGS PAD DRAWING**

MMIC Steps on the wafer are 4.5 and 4.1 mm along X and Y coordinated respectively, dicing typically reduce the die by 30um.

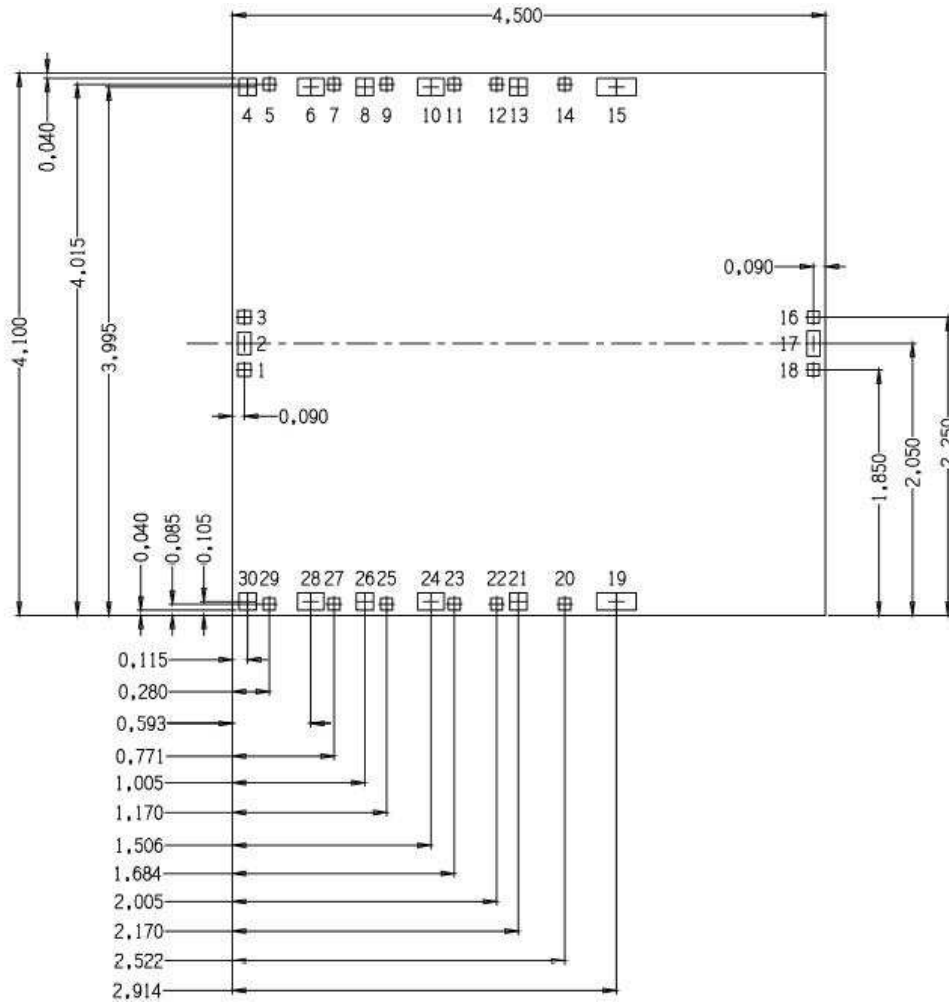

**CGY2139AUH/C2 Pad layout drawing**

## PACKAGE

Type	Description	Terminals	Pitch (mm)	Package size (mm)
DIE	100% RF and DC on-wafer tested	30	-	4.5 x 4.1 x 0.1

## SOLDERING

To avoid permanent damages or impact on reliability during soldering process, die temperature should never exceed 330°C.

Temperature in excess of 300°C should not be applied to the die longer than 1mn

Toxic fumes will be generated at temperatures higher than 400°C

## ORDERING INFORMATION

Generic type	Package type	Version	Sort Type	Description
CGY2139A	UH	C2	-	On-Wafer measured Die
CGY2139A	UH	C2	EK	Test-jig



## **DEFINITIONS**

### **Limiting values definition**

Limiting values given are in accordance with the Absolute Maximum Rating System (IEC 60134). Stress above one or more of the limiting values may cause permanent damage to the device. These are stress ratings only and operation of the device at these or at any other conditions above those given in the Characteristics sections of the specification is not implied. Exposure to limiting values for extended periods may affect device reliability.

### **Application information**

Applications that are described herein for any of these products are for illustrative purposes only. OMMIC makes no representation or warranty that such applications will be suitable for the specified use without further testing or modification.

## **DISCLAIMERS**

### **Life support applications**

These products are not designed for use in life support appliances, devices, or systems where malfunction of these products can reasonably be expected to result in personal injury. OMMIC's customers using or selling these products for use in such applications do so at their own risk and agree to fully indemnify OMMIC for any damages resulting from such application.

### **Right to make changes**

OMMIC reserves the right to make changes, without notice, in the products, including circuits, standard cells, and/or software, described or contained herein in order to improve design and/or performance. OMMIC assumes no responsibility or liability for the use of any of these products, conveys no licence or title under any patent, copyright, or mask work right to these products, and makes no representations or warranties that these products are free from patent, copyright, or mask work right infringement, unless otherwise specified.