

MULTIPIN CONNECTORS

DSX series

MIL-C-81659B / ARINC 404



COMPANY Profile

Founded in 1952 in France, RADIALL started as a family owned company making coaxial plugs. Today, RADIALL is an international and global manufacturer of interconnect components including **RF coaxial connectors and cable assemblies, antennas, fiber optic components, microwave components, and multipin connectors** for the Automotive, Civil Aviation, Defense, Industrial, Medical, Space and Telecommunication markets.



QSE (Quality Safety Environment) POLICY

RADIALL maintains a quality management system conforming to international standards, including for environmental protection. Our customers' recognition of our products quality and sustainability of our company, demonstrates the efficiency of our quality system.



CERTIFICATIONS

Certified ISO 9001 since 1994, RADIALL has a pro-active policy in terms of conforming to international standards. Today, all RADIALL sites are certified to **ISO 9001:2000** and some

dedicated activities are AS9100 or TS 16949. Our process approach gives us the tool for continuous improvement in all our activities.



A major step in our environment policy was the **ISO 14001** certification of our Voreppe plant in 2001. RADIALL complies with European directives such as **RoHS** for hazardous substance restrictions and **EuP** for environmentally friendly designs of energy-using products.

Some RADIALL product lines are on **MIL, ESA/SCC** Qualified Product Lists.

RADIALL is therefore proud to be recognized by leading industrial customers for its quality of service and products.



A WORLDWIDE ENGINEERING & MANUFACTURING CAPABILITY

RADIALL has expertise centers and manufacturing locations on 3 continents. Through 9 industrial sites, RADIALL offers customers the proximity they need to obtain the best quality service and delivery performance. Our facilities feature state of the art equipment for the many technologies involved in the design, manufacturing and assembly of interconnect products. This international organization allows RADIALL to offer its outstanding quality products at competitive prices.

Technical information and sales contacts are available on: www.radiall.com

Introduction	4	DSX ARINC 404 shell type B	
DSX MIL-C-81659B		Part numbering	41
Part numbering	5	Technical characteristics	42
Technical characteristics	6-7	Contact arrangements	43-44
Contact arrangements	8 to 10	Signal and power contacts	45
Signal and power contacts	11	Contacts with pc tail	45
Thermocouple contacts	11	Thermocouple contacts	46
Fiber optic contacts	12	Fiber optic contacts	46
Contacts with pc tail	12	Contacts with wire wrap post	46
Contacts with wire wrap post	12	Solder cup contacts	46
Coaxial crimp contacts	13 to 15	Coaxial crimp contacts	47-48
Concentric twinax crimp contacts	16	Accessories	48
Triax crimp contacts	16	Shell size 1 dimensions	49
Triax contacts with pc tail	17	Shell size 2 dimensions	49
Modification code	18 to 20	Shell size 3 dimensions	50
Polarization code	21 to 23	Shell size 4 dimensions	51
Accessories	24-25	DSX EMI/RFI	
Shell size 1 dimensions	26	Introduction	52
Shell size 2 dimensions	27	Part numbering	52
Shell size 3 dimensions	28	Technical characteristics	52
Shell size 4 dimensions	29	DSX ARINC 404 shell type A	
Panel cut-out	30	Part numbering	53
Cross reference from military to Radiall p/n	31 to 34	Technical characteristics	54
DSX F		Modification code	54
Part numbering	35	Contact arrangements	55
Technical characteristics	36	Contacts	55
Contacts with pc tail	36	Accessories	55
Contacts with wire wrap post	36	Shell dimensions	55
Coaxial crimp contacts	36	Panel cut-out	55
Modification code	36	Wiring Instructions	
Polarization code	36	Code A	56
Accessories	36	Code B	57
DSX DATA BUS		Code C	58
Part numbering	37	Code D	58
Technical characteristics	37	Code E	59
Contact arrangements	38	Code F	59
B2TP, H2TP, B4TP & H4TP connector	39	Code G	60
42B2 connector	40	Code H	60
Twinax contacts	40	Code J	61
		Code K	62
		Code L	63
		Code M	64
		Code N	64
		Code P	65
		Code R	65
		Code S	66
		Part number index	67

DSX rack and panel series are multipin rectangular connectors used to electrically interface avionics equipment to equipment rack. Usually the plug is installed on the equipment rack and the receptacle on the avionics box. The mated locking mechanism is provided for by the equipment and cabinet and is not a part of the connector pair.

These connectors are widely used in applications such as :

- Commercial / military aircraft and helicopters,
- Radar systems,
- Power circuits,
- In-flight electronic instrumentation,
- Flight simulators, etc.....

The following versions are offered :

DSX - MIL-C-81659B : connectors conforming to MIL-C-81659B including connectors listed on the QPL81659

DSX - ARINC 404 shell type B : connectors conforming to ARINC 404 shell type B – polarized shells

DSX - ARINC 404 shell type A : connectors conforming to ARINC 404 shell type A – single shell (without polarization)

DSX - F : connectors for front release front removable contacts (receptacle only)

DSX - DATA BUS : connectors for interconnection of multiplexed digital links

DSX EMI/RFI : shielded connectors

DSX - MIL-C-81659B

These connectors fully conform to MIL-C-81659B specification and are listed on the associated Qualified Product List. They are available in four shell sizes (1, 2, 3 and 4) which can respectively accept 1, 2, 3 and 4 inserts. Inserts are offered in various contact arrangements accommodating rear release rear removable signal (size 22), power (sizes 20HD, 16,12 and 5), coaxial (sizes 1, 3, 5, 7, 9 and 15), twinax (sizes 9 and 5), triax (sizes 5 and 9) contacts in crimp, wire wrap or PC tail termination. Fiber optic contacts are also offered. Both environmental and non environmental connectors are available.

Mismatching is prevented by a polarizing system which provides 216 polarizing positions. For MIL part numbers, applicable polarizing positions range from 00 through 99 only.

DSX - ARINC 404 shell type B

These connectors are the commercial version. Compare to the military version :

- They use both size 20HD and size 20 contacts.
- They are non environmental. Inserts are fitted with a rubber separator on their wiring rear face which does not provide sealing but wire protection.
- Removable size 5 and 9 coaxial contacts are not interchangeable with those of the military type.
- Insert retention plate is gold anodized instead of blue anodized on the military version.

DSX - ARINC 404 shell type A

DSX - ARINC 404 shell type A connectors are available in shell size 1 only. They accommodate ARINC 404 shell type B inserts ; only one insert can be installed in the connector shell. They have no polarizing system, mismatching is prevented by keystone shaped shells. DSX ARINC 404 shell type A size 1 connectors cannot be fitted with any backshell.

DSX - F

DSX - F receptacle connectors are available in four shell sizes (1, 2, 3 and 4) and are designed to be fitted with front release front removable contacts offered in pc tail and wire wrap termination. Inserts are offered fitted or not with an interfacial seal (in both cases they are not fitted with a separator) and are available in the following contact arrangements : 106, 67, 57, 45, 40, 33C4, 26.

DSX - F connectors are fully intermateable with connectors of the ARINC 404 shell type B and MIL-C-81659 types.

DSX - DATA BUS

These connectors have been designed to ensure the interconnection of multiplexed digital links used in military equipments.

DSX - EMI / RFI

In response to the continuing development of electronic systems used in ever harsher environments, these connectors have been designed to improve the shielding effectiveness against electromagnetic and radiofrequency interferences (EMI/RFI) as well as electromagnetic pulses (EMP).

DSX N 4 P S 40 S S8S S26S S45P 00 01

Series _____

Class _____

N : non environmental (without grommet and interfacial seal)
 E : environmental (with grommet and interfacial seal)
 T : connector with interfacial seal on insert with protruding contacts only

Shell size _____

1 : one gang shell
 2 : two gang shell
 3 : three gang shell
 4 : four gang shell

Shell type _____

R : receptacle
 P : plug

Termination style _____

X : without contacts
 S : crimp (see note 1)
 V : wire wrap 2 levels
 W : wire wrap 3 levels } (see note 4)
 Y : PC tail

Contact arrangement _____

(see note 2)
 see available contact arrangements on pages 8 to 10.

Contact type _____

S : socket
 P : pin

Gang B _____

Gang C _____

Gang D _____

Modification code _____

(see pages 18 to 20)

Polarization code _____

(see note 3 and pages 21 to 23)

Gang A

Notes :

- 1 If you need to use reduced crimp barrel, thermocouple or fiber optic contacts , use code X and order contacts separately.
- 2 For MC2, MC3 and C8 contact arrangements which include coax contacts, use termination code X and order coax contacts separately.
- 3 Without polarization code the connector is delivered with the polarizing system unassembled
 Polarization code 00 : the connector is delivered without polarizing system
 Polarization code from 01 to 216 : the connector is delivered with the polarization hardware assembled as defined by code.
 Polarization codes for connectors qualified to MIL-C-81659B are ranging from 00 to 99 only.
- 4 PC tail and wire wrap contacts are delivered installed.
 For 67, 32C4 and 33C4 contact arrangements, size 16 contacts are delivered not installed and in crimp termination.

Very Important note : If you want to get connectors marked with the military part number (i.e. M81659/66A2-0083) you must order by using the military part number. RADIALL part numbers qualified to MIL-C-81659B versus military part numbers are listed on pages 31 to 34.

MATERIALS

DESCRIPTION	MATERIAL	PLATING
Shell	Aluminum alloy	Cadmium yellow chromate or electroless nickel
Insert	Thermosetting resin	
Metallic insert	Aluminum alloy	Cadmium clear chromate or electroless nickel
Interfacial seal & grommet	silicone rubber	
Retention clip	Copper alloy	
Contact	Copper alloy	Gold over nickel underplate.
Insert retention plate	Aluminum alloy	Blue anodized.
Polarizing posts	Stainless steel	
Polarizing keys	Zinc alloy	Cadmium yellow chromate.
Polarizing keys retention plate	Aluminum alloy	Cadmium yellow chromate or electroless nickel blue painted.
Screws,washers,clinch-nuts	Corrosion resistant steel	

ELECTRICAL CHARACTERISTICS

CONTACT SIZE	AWG	CROSS SECTION (mm ²)	MIN OUTSIDE DIA. Inches (mm)	MAX OUTSIDE DIA. Inches (mm)	MAX CURRENT (A)
22	22	0.38	.030 (0.76)	.055 (1.4)	5
	24	0.21			3
	26	0.14			2
20HD	20	0.60	.039 (1)	.071 (1.8)	7.5
	22	0.38			5
	24	0.21			3
16	16	1.34	.067 (1.7)	.102 (2.6)	13
	18	0.93			10
	20	0.60			7.5
12	12	3.18	.094 (2.4)	.134 (3.4)	23
	14	1.91			17
	16	1.34			13
For cavity 5	8	9.00	.134 (3.4)	.255 (6.48)	46
	10	5.00			33
	12	3.18			23
	14	1.91			17

Magnetic permeability : < 2
 Insulation resistance : >5000 MΩ
 Dielectric withstanding voltage : See contact arrangements on pages 8 to 10.
 Contact resistance : According to requirements of MIL-C-39029D

Coax contacts electrical characteristics

Nominal impedance : 50 Ω
 VSWR
 - sizes 5, 7, 9 : 1.3 from DC to 1500 MHz
 - sizes 1 and 3 : 1.3 from DC to 5000 MHz

MECHANICAL AND ENVIRONMENTAL

Temperature range : -65°C/+125°C
 Temperature life : 1000 hours at 125°C
 Salt spray : MIL-STD-1344A method 1001.1 test condition B (48 hours)
 Altitude moisture injection : Insulation resistance > 100 M Ω altitude 50000 feet
 Fluid resistance : resistance to 20 hours immersion in fluids MIL-H-5606 & MIL-L-23699
 Durability : 500 mating and unmating cycles
 Vibration : MIL-STD-1344A method 2005 test condition IV (20g - 10-2000Hz)
 Shock : MIL-STD-1344A method 2004 (50g - 11ms - half sine)
 Mating force : <45 pounds (200 N) per insert
 Insert retention force : > 120 lbs (534N) in each direction
 Contact retention force : max axial displacement = .012 inches (0,3mm)

CONTACT SIZE	22	20HD	16	12
axial load lbs (N)	15 (66N)	20 (89N)	25 (111N)	30 (133.5N)

PIN INSERT MATING SIDE SHOWN

C5*

45

Number of contacts	Contact size	Location
5	5 (power)	1 to 5

DWV = 3500 V - 60Hz

This insert is available in class N only

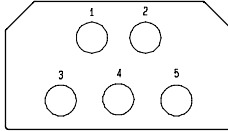

Number of contacts	Contact size	Location
45	20HD	1 to 45

DWV = 1500 V - 60Hz

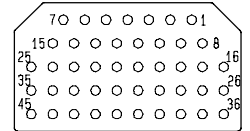

8*

57

Number of contacts	Contact size	Location
8	12	1 to 8

DWV = 1500 V - 60Hz

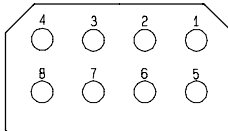

Number of contacts	Contact size	Location
57	20HD	1 to 57

DWV = 1500 V - 60Hz

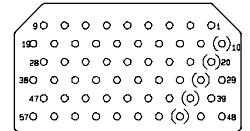

D8

67

Number of contacts	Contact size	Location
4	16	1 to 4
4	12	5 to 8

DWV = 1500 V - 60Hz

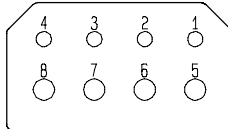

Number of contacts	Contact size	Location
64	20HD	1, 2 & 6 to 67
3	16	3, 4 & 5

DWV = 1000 V - 60Hz

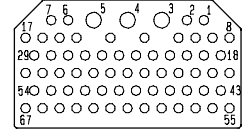

26

106

Number of contacts	Contact size	Location
26	16	1 to 26

DWV = 1500 V - 60Hz

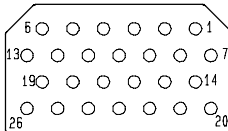

Number of contacts	Contact size	Location
106	22	1 to 106

DWV = 1000 V - 60Hz

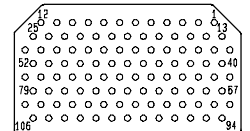

40

40C1

Number of contacts	Contact size	Location
40	20HD	1 to 40

DWV = 1500 V - 60Hz

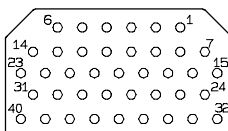

Number of contacts	Contact size	Location
1	5 (coax)	A1
39	20HD	1 to 39

DWV = 1500 V - 60Hz

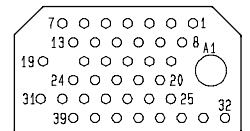

Contact arrangements names followed by "*" are not referred to by MS3157 and MIL-C-81659B.

PIN INSERT MATING SIDE SHOWN

40T1*

Number of contacts	Contact size	Location
1	5 (Coax)	A1
39	20HD	1 to 39

DWV = 1500 V - 60Hz
Size 5 contact cavity grounded to the shell

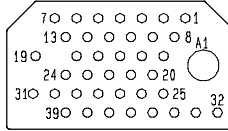

33C4

Number of contacts	Contact size	Location
4	5 (Coax)	A1 to A4
4	16	1 to 4
25	20HD	5 to 29

DWV = 1000 V - 60Hz

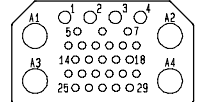

32C2

Number of contacts	Contact size	Location
2	5 (Coax)	A1 & A2
30	20HD	1 to 30

DWV = 1000 V - 60Hz

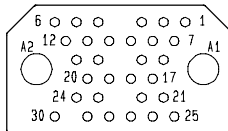

33T4*

Number of contacts	Contact size	Location
4	5 (Coax)	A1 to A4
4	16	1 to 4
25	20 HD	5 to 29

DWV = 1000 V - 60Hz
Size 5 contact cavities grounded to the shell

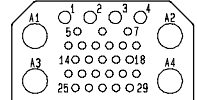

32T2*

Number of contacts	Contact size	Location
2	5 (Coax)	A1 & A2
30	20HD	1 to 30

DWV = 1000 V - 60Hz
Size 5 contact cavities grounded to the shell

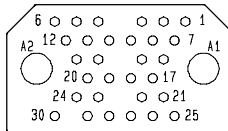

36C7*

Number of contacts	Contact size	Location
7	5 (Coax)	A1 to A7
29	22	1 to 29

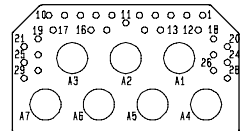

32C4

Number of contacts	Contact size	Location
4	9 (Coax)	29 to 32
4	16	8, 9 & 23, 24
24	20HD	1 to 7 & 10 to 22 & 25 to 28

DWV = 1500 V - 60Hz

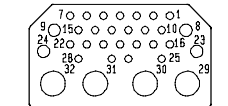

36T7*

Number of contacts	Contact size	Location
7	5 (Coax)	A1 to A7
29	22	1 to 29

Size 5 contact cavities grounded to the shell

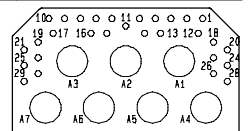

32T4*

Number of contacts	Contact size	Location
4	9 (Coax)	29 to 32
4	16	8, 9 & 23, 24
24	20HD	1 to 7 & 10 to 22 & 25 to 28

DWV = 1500 V - 60Hz
Size 9 contact cavities grounded to the shell

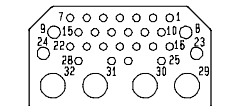

MC2

Number of contacts	Contact size	Location
2	1	1, 2

This insert is metallic

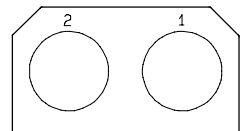

Contact arrangements names followed by "*" are not referred to by MS3157 and MIL-C-81659B.

PIN INSERT MATING SIDE SHOWN

MC3

Number of contacts	Contact size	Location
2	7 (Coax)	1 & 3
1	3 (Coax)	2

This insert is metallic

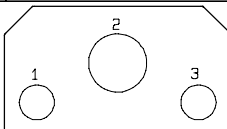

C8

Number of contacts	Contact size	Location
8	9 (Coax)	1 to 8

DWV = 1000 V - 60Hz

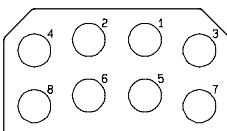

T8*

Number of contacts	Contact size	Location
8	9 (Coax)	1 to 8

Size 9 contact cavities grounded to the shell

Note : available for pin contact only

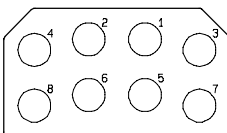

00*

Number of contacts	Contact size	Location
0	/	/



Contact arrangements names followed by "*" are not referred to by MS3157 and MIL-C-81659B.

SIGNAL AND POWER CRIMP CONTACTS SIZES 22, 20HD, 16, 12 & 5

CONTACT SIZE	AWG	WIRE			PIN RADIALL P/N (MIL P/N)	SOCKET RADIALL P/N (MIL P/N)	CRIMPING TOOL RADIALL P/N (MIL P/N)	POSITIONER RADIALL P/N (MIL P/N)	SELECTOR	INS/EXT TOOL RADIALL P/N (MIL P/N)	
		cross section (mm ²)	wire outside dia. inch (mm)	stripping length inch (mm)							
22	22	0.38	.055	.138	616200 (M39029/11-144)	616300 (M39029/12-148)	282281 (M22520/2-01)	282970 (M22520/2-23)	4	282885 (M81969/1-01)	
	24	0.21	(1.4)	(3.5)					3		
	26	0.14							3		
22 reduced crimp barrel	28	0.093	.047	.138	616201	616301		5			
	30	0.055	(1.2)	(3.5)				4			
20HD	20	0.60	.071	.157	616210 (M39029/11-145)	616310 (M39029/12-149)		282281 (M22520/2-01)	282971 (M22520/2-08)	7	282886 (M81969/1-02)
	22	0.38	(1.8)	(4.0)						6	
	24	0.21								5	
20HD reduced crimp barrel	26	0.14	.049	.157	616211	616311			6		
	28	0.093	(1.25)	(4.0)					5		
30	0.055			4							
16	16	1.34	.102	.236	616230 (M39029/11-146)	616330 (M39029/12-150)	282291 (M22520/1-01)		282972 (M22520/1-02)	6	282546 (M81969/1-03)
	18	0.93	(2.6)	(6.0)						5	
	20	0.60								4	
16 reduced crimp barrel	20	0.60	.071	.236	616231	616331			5		
	22	0.38	(1.8)	(6.0)				4			
24	0.21										
12	12	3.18	.134	.236	616240 (M39029/11-147)	616340 (M39029/12-151)		282291 (M22520/1-01)	282579 (M22520/1-11)	8	282547 (M81969/28-02)
	14	1.91	(3.4)	(6.0)						7	
	16	1.34								6	
For cavity 5	12	3.18	.134	.315	616261	616361			282296 (DANIELS M300BT) see note 1		1
	14	1.91	(3.4)	(8.0)			1				
	10	5.0	.234	.315			5				
8	9.0	(5.7)	(8.0)	616266	616366	282557	8				

Note 1 : DANIELS WA27-309-EP air pressure tool with crimp setting 5 can also be used. Crimp setting 5 is not adjustable and must be set by the factory.

THERMOCOUPLE CONTACTS SIZES 22 & 20HD MADE OF CHROMEL

CONTACT SIZE	AWG	WIRE			PIN	SOCKET	CRIMPING TOOL RADIALL P/N (MIL P/N)	POSITIONER RADIALL P/N (MIL P/N)	SELECTOR	INS/EXT TOOL RADIALL P/N (MIL P/N)
		cross section (mm ²)	wire outside dia. inch (mm)	stripping length inch (mm)						
22	22	0.38	.055	.138	620280	620380	282281 (M22520/2-01)	282970 (M22520/2-23)	4	282885 (M81969/1-01)
	24	0.21	(1.4)	(3.5)					3	
	26	0.14							3	
20HD	20	0.60	.071	.157	620290	620390	282281 (M22520/2-01)	282971 (M22520/2-08)	7	282886 (M81969/1-02)
	22	0.38	(1.8)	(4.0)					6	
	24	0.21							5	

THERMOCOUPLE CONTACTS SIZES 22 & 20 HD MADE OF ALUMEL

CONTACT SIZE	AWG	WIRE			PIN	SOCKET	CRIMPING TOOL RADIALL P/N (MIL P/N)	POSITIONER RADIALL P/N (MIL P/N)	SELECTOR	INS/EXT TOOL RADIALL P/N (MIL P/N)
		cross section (mm ²)	wire outside dia. inch (mm)	stripping length inch (mm)						
22	22	0.38	.055	.138	620281	620381	282281 (M22520/2-01)	282970 (M22520/2-23)	4	282885 (M81969/1-01)
	24	0.21	(1.4)	(3.5)					3	
	26	0.14							3	
20HD	20	0.60	.071	.157	620291	620391	282281 (M22520/2-01)	282971 (M22520/2-08)	7	282886 (M81969/1-02)
	22	0.38	(1.8)	(4.0)					6	
	24	0.21							5	

FIBER OPTIC TERMINI SIZES 16 & 12

Fiber optic contacts are called Termini. Fiber optic termini are shown in the table below. Tooling used to connect the fiber optic cable to the termini is available. For more information, contact your nearest RADIAL representative.

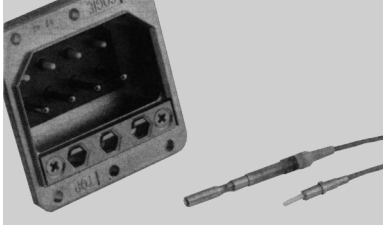

CONTACT SIZE	VERSION	CABLE DIA.	FIBER SIZE	PIN	SOCKET	INS/EXT TOOL
16	CERAMIC	.059 (1.5)	50/125	F724005000	F724104000	282929/282892
			100/140	F724002000	F724101000	
	METAL	.071 (1.8)	HCS200	F724041000	F724140000	
			HCS400	F724045000	F724144000	
12		.098 (2.5)	HCS200/280	F724241200	F724341200	EXT 282 945

SIZES 22 & 20HD PC TAIL CONTACTS

CONTACT SIZE	CONTACT ARRANGEMENT	PIN	SOCKET	EXTRACTION TOOL	DIMENSIONS							
					A	B	C dia	D	E			
22	106	/	616379	282890	.240/.209 (6.1/5.3)	.256 (6.5)	.023 (0.6)	.994/1.013 (25.25/25.75)	.061/.069 (1.55/1.75)			
			616303		.567/.535 (14.4/13.6)	.370 (9.4)						
	36C7 for pin contacts	616206*	.232/.263 (5.9/6.7)		.149 (3.8)	/		/	.293/.309 (7.85/7.44)			
		/	.032/.004 (0.82/0.10)									
20HD	36C7 for socket contacts	/	616306	282891	.157/.130 (4.00/3.30)	.370 (9.4)	.031 (0.8)	1.122/1.108 (28.50/28.15)	/			
			616303		.461/.433 (11.72/11.00)							
	40-45-57-32C2-32C4-40C1	616216*	/		/			.259/.299 (6.6/7.6)	/	.023 (0.6)	1.23/1.25 (31.25/31.75)	.293/.305 (7.45/7.75)
								67-33C4				
40-45-57-32C2-32C4-40C1	616223	616323*	/	.138/.169 (3.5/4.3)								
67-33C4				.126/.157 (3.2/4)								

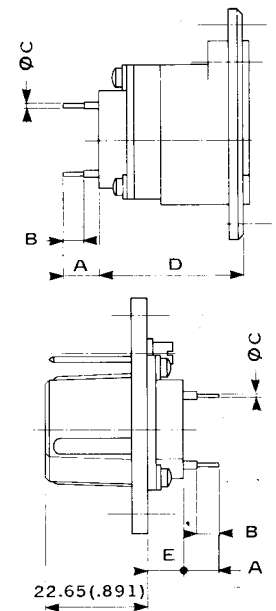

Connectors delivered in the "Y" termination style will be fitted with contacts marked by "*" (see above table). If you want to use an other kind of pc tail contact, use termination style "X" when ordering the connector and order contacts separately.

SIZES 22 & 20HD WIRE WRAP CONTACTS

CONTACT SIZE	AWG	CONTACT ARRANGEMENT	PIN	SOCKET	INS. TOOL	DIMENSIONS		
						A	B	C
22	26 28 30	106	610203 (2 wrap levels)	610303 (2 wrap levels)	282948	.393/.433 (10/11)	.994/1.013 (25.25/25.75)	.061/.069 (1.55/1.75)
			610204 (3 wrap levels)	610304 (3 wrap levels)		.492/.531 (12.5/13.5)		
20HD	26 28 30	40-45-57 32C2-32C4-40C1	610214 (2 wrap levels)	610314 (2 wrap levels)		.405/.445 (10.3/11.3)	1.230/1.250 (31.25/31.75)	.293/.305 (7.45/7.75)
		67-33C4				.387/.431 (9.85/10.95)		

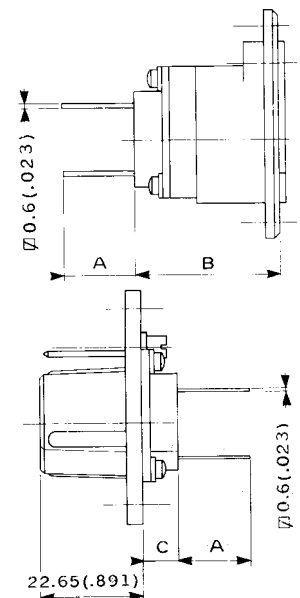

COAXIAL CRIMP CONTACTS SIZE 1

CONTACT SIZE	CONTACT ARRANGEMENT	CABLE	PIN	SOCKET	CENTER CONTACT			OUTER BODY			WIRING INSTR.
					CRIMPING TOOL RADIALL P/N (MIL P/N)	POSITIONER RADIALL P/N (MIL P/N)	SEL.	CRIMPING TOOL RADIALL P/N (MIL P/N)	DIE RADIALL P/N (MIL P/N)	HEX.	
1	MC2	UT 141 RG 402	616005	/	solder contact						C1 page 58
		RG 58 RG 141 KX 15	616006 right angle	/	solder contact			282293 (M22520/5-01)	282246 (M22520/5-05)	A	E page 59
		RG 213 KX 4	/	616102001	282291 (M22520/1-01)	282997 (M22520/1-13)	8		282247 (M22520/5-61)	A	A1 page 56
		RG 214 RG 225	/	616103001							A6 page 56
		RG 142	616007 right angle	/	solder contact				282246 (M22520/5-05)	A	E page 59
		RG 142 RG 223	/	616107001	282291 (M22520/1-01)	282997 (M22520/1-13)	7				A2 page 56
		RG 174 KX 22	/	616100	solder contact				B	N page 64	
		RD 316	616004 right angle	/	solder contact					P page 65	
		/	616009	/	SMA termination						NA

For other cables, consult RADIALL

PART NUMBER	616004 - 616006 - 616007	616009 - 616100 - 616103001 616106 - 616102001	616003 - 616005 - 616107001
Dielectric withstanding voltage at sea level (V rms)	1000	1500	2500

COAXIAL CRIMP CONTACTS SIZE 3

CONTACT SIZE	CONTACT ARRANGEMENT	CABLE	PIN	SOCKET	CENTER CONTACT			OUTER BODY			WIRING INSTR.		
					CRIMPING TOOL RADIALL P/N (MIL P/N)	POSITIONER RADIALL P/N (MIL P/N)	SEL.	CRIMPING TOOL RADIALL P/N (MIL P/N)	DIE RADIALL P/N (MIL P/N)	HEX.			
3	MC3	RG 142 RG 223	616013	/	solder			282293 (M22520/5-01)	282246 (M22520/5-05)	A	A2 page 56		
		RG 316	616015 right angle	/	282291 (M22520/1-01)	282997 (M22520/1-13)	7				B	R page 65	
		UT 141 RG 402	616014	/						solder			
		RG 214 RG 225	/	616111	282291 (M22520/1-01)	282997 (M22520/1-13)	8			282293 (M22520/5-01)	282247 (M22520/5-61)	A	A1 page 56
		RG 213 KX 4	/	616112									

For other cables, consult RADIALL

Dielectric withstanding voltage at sea level : 1500 V rms. Except 1000 V rms for 616015.

COAXIAL CRIMP CONTACTS SIZE 5

The following contacts have to be fitted with a sealing boot when used in DSX E connectors (see page 24). Coaxial cavities without any contact can be fitted with sealing plugs when used in DSX E connectors.

CONTACT SIZE	CONTACT ARRANGEMENT	CABLE	PIN	SOCKET	CENTER CONTACT			OUTER BODY			WIRING INSTR.								
					CRIMPING TOOL RADIALL P/N (MIL P/N)	POSITIONER RADIALL P/N (MIL P/N)	SEL.	CRIMPING TOOL RADIALL P/N (MIL P/N)	DIE RADIALL P/N (MIL P/N)	HEX.									
5	32C2 32T2 33C4 33T4 36C7 36T7 40C1 40T1	RG 58 KX 15	616120	616020	282281 (M22520/2-01)	282974	6	282293 (M22520/5-01)	282246 (M22520/5-05)	A	A4 page 56								
		RG 141	616120	616020								8							
		RG 142 RG 223 KX 23	616121	616021								8							
		RG 179 RG 188 RG 174 RG 316 KX 22	616122	616022								7							
		RG 179 RG 187	/	616022002								DANIELS K345							
		RG 196 RG 178 KX 21	616123	616023								282974	6						
		RG 195 RG 180	616124	616024															
		RG 316 DS	616163	616026															
		UT .085	616125	/								solder			B	B1 page 57			
		UT .141	616128	616028								A4 page 56							
												B1 page 57							
												C4 page 58							

For other cables, consult RADIALL
Extraction tool : 282946 (M81969/28-01)
Dielectric withstanding voltage at sea level : 750 V rms.

COAXIAL CRIMP CONTACTS SIZE 7

CONTACT SIZE	CONTACT ARRANGEMENT	CABLE	PIN	SOCKET	CENTER CONTACT			OUTER BODY			WIRING INSTR.	
					CRIMPING TOOL RADIALL P/N (MIL P/N)	POSITIONER RADIALL P/N (MIL P/N)	SEL.	CRIMPING TOOL RADIALL P/N (MIL P/N)	DIE RADIALL P/N (MIL P/N)	HEX.		
7	MC3	RG 58 RG 141 KX 15	610120	/	solder			282293 (M22520/5-01)	282246 (M22520/5-05)	A	A3 page 56	
		RG 174 RG 316 KX 22 RG 188	610126	/								B
		RG 58 KX 15	/	616030	282281 (M22520/2-01)	282550 (DANIELS K345)	6			A	A4 page 56	
		RG 141	/	616030								8
		RG 142 RG 223 KX 23	/	616031								8
		RG 174 RG 316 KX 22	/	616032								7
												B

For other cables, consult RADIALL
Extraction tool : 282946 (M81969/28-01)
Dielectric withstanding voltage at sea level : 750 V rms.

COAXIAL CRIMP CONTACTS SIZE 9

Add **001** to the end of part numbers in bold letter to order for **environmental** size 9 coax contacts which are to be installed in **C8, T8, 32C4** and **32T4** inserts. Coaxial cavities without any contact can be fitted with sealing plugs when used in DSX E connectors.

CONTACT SIZE	CONTACT ARRANGEMENT	CABLE	PIN	SOCKET	CENTER CONTACT			OUTER BODY			WIRING INSTR.	
					CRIMPING TOOL RADIALL P/N (MIL P/N)	POSITIONER RADIALL P/N (MIL P/N)	SEL.	CRIMPING TOOL RADIALL P/N (MIL P/N)	DIE RADIALL P/N (MIL P/N)	HEX.		
9	C8 T8 32C4 32T4	RG 58 KX 15	616140	616040	282281 (M22520/2-01)	282974	6	282293 (M22520/5-01)	282246 (M22520/5-05)	A	A4 page 56	
		RG 141										
		RG 142 RG 223 KX 23	616141	616041								8
		RG 174 RG 179 RG 188 RG 316 KX 22	616142	616042								7
		RG 178 RG 196 KX 21	616143	616043								6
		RG 180 RG 195	616144	616044								6
									B	B1 page 57		
										A4 page 56		

For other cables, consult RADIALL
Extraction tool : 282946 (M81969/28-01)
Dielectric withstanding voltage at sea level : 750 V rms.

COAXIAL CRIMP CONTACTS SIZE 15

CONTACT SIZE	CONTACT ARRANGEMENT	CABLE	PIN	SOCKET	CENTER CONTACT			OUTER BODY			WIRING INSTR.	
					CRIMPING TOOL RADIALL P/N (MIL P/N)	POSITIONER RADIALL P/N (MIL P/N)	SEL.	CRIMPING TOOL RADIALL P/N (MIL P/N)	DIE RADIALL P/N (MIL P/N)	HEX.		
15	D8 26 67 32C4 32T4 33C4 33T4	RG 316 RG 179	616154	618050	282281 (M22520/2-01)	282555 DANIELS K370	2	282292 (M22520/4-01)	282556		A5 page 56 for pin M page 64 for socket	
		KX 22 DS	616150								G page 60 for pin M page 64 for socket	
		KX 21 DS	616151								618053	H page 60 for pin M page 64 for socket
		RG 178 KX 21	616153								618054	

For other cables, consult RADIALL
Dielectric withstanding voltage at sea level : 350 V rms.

CONCENTRIC TWINAX CRIMP CONTACTS SIZE 5

CONTACT SIZE	CONTACT ARRANGEMENT	CABLE	PIN	SOCKET	WIRING INSTR.
The following contacts have to be installed in the non environmental inserts					
5	32C2 32T2 40C1 40T1	MIL-C-17/176-00002	616195001	616095001	J page 61
	36C7 36T7 33C4 33T4	PAN 6421	616195005	616095005	
The following contacts have to be installed in the environmental inserts					
5	32C2 32T2 33C4 33T4 40C1 40T1	MIL-C-17/176-00002	616195009	616095009	J page 61
	36C7 36T7		616195012	/	

CONCENTRIC TWINAX CRIMP CONTACTS SIZE 9

CONTACT SIZE	CONTACT ARRANGEMENT	CABLE	PIN	SOCKET	WIRING INSTR.
The following contacts have to be installed in the non environmental inserts					
9	C8 T8 32C4 32T4	MIL-C-17/176-00002	616196003	616096003	J page 61
The following contacts have to be installed in the environmental inserts					
9	C8 T8	MIL-C-17/176-00002	/	616096006	J page 61
	32C4 32T4		616196004	616096004	

TRIAx CRIMP CONTACTS SIZE 5

CONTACT SIZE	CONTACT ARRANGEMENT	CABLE	PIN	SOCKET	WIRING INSTR.
The following contacts have to be installed in the non environmental inserts					
5	33C4 33T4 32C2 32T2 40C1 40T1 36C7 36T7	RGX 179	616195004	616095004	K page 62
		ST5M 1323-1	616195007	616095007	L page 63
		HS4863-1 HS4863-2	616195000	616095000	K page 62
The following contacts have to be installed in the environmental inserts					
5	36C7 36T7	RGX 179	/	616095010	K page 62

TRIAx CRIMP CONTACTS SIZE 9

CONTACT SIZE	CONTACT ARRANGEMENT	CABLE	PIN	SOCKET	WIRING INSTR.
The following contacts have to be installed in the non environmental inserts					
9	C8 T8 32C4 32T4	RGX 179	616196001	616096001	K page 62
The following contacts have to be installed in the environmental inserts					
9	32C4 32T4	RGX 179	/	616096002	K page 62

The extraction tool to be used for all the above contacts is M81969/28-01 (RADIAL 282946).

TRIAX CONTACTS WITH PC TAIL SIZE 5

The contacts shown in the table below are rear release rear removable contacts.

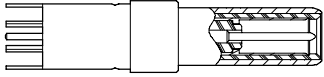
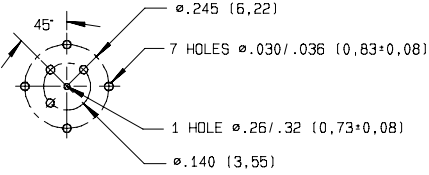
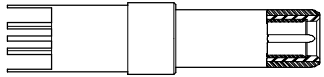
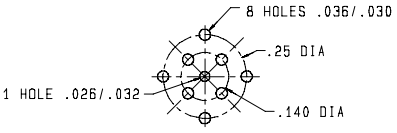
contact type	p/n	contact drawing	rear extension from the insert	pc drill patern
pin	616195003		32C2, 32T2, 33C4, 33T4, 40C1 & 40T1 = .125/.158 (3.2/4.0)	
	616195008		36C7 & 36T7 = .212/.240 (5.40/6.10)	

TRIAX CONTACTS WITH PC TAIL SIZE 9

The contacts shown in the table below are rear release rear removable contacts.

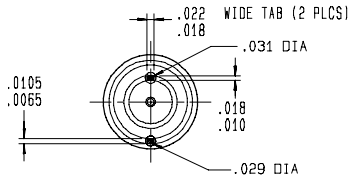
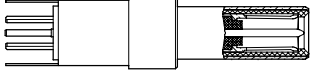
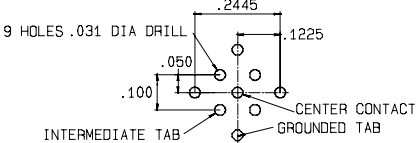
contact type	p/n	contact drawing	rear extension from the insert	pc drill patern
pin	616196005		C8 & T8 = .051/.085 (1.30/2.15) 32C4 & 32T4 = .253/.288 (6.45/7.30)	
	616196007		C8 & T8 = 0 32C4 & 32T4 = .145/.172 (3.70/4.35)	

Extraction tool to be used for all the above contacts is M81969/28-01 (RADIALL 282946).

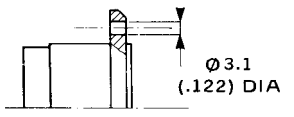
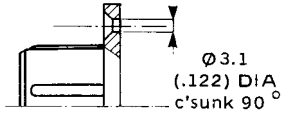
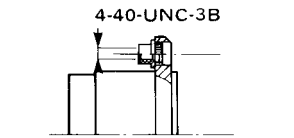
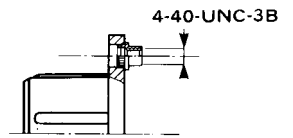
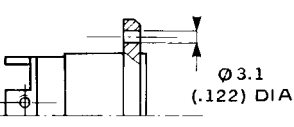
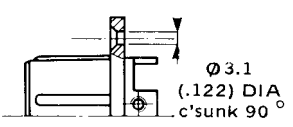
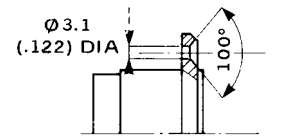
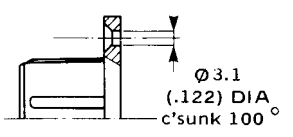
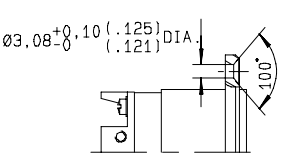
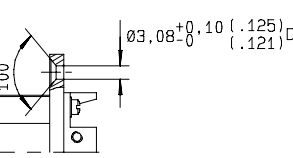
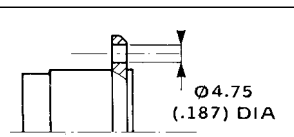
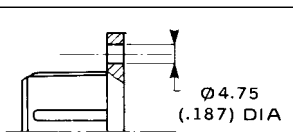
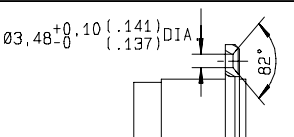
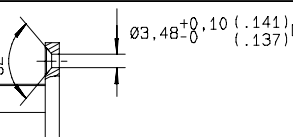
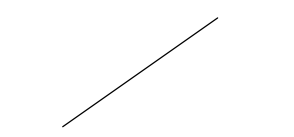
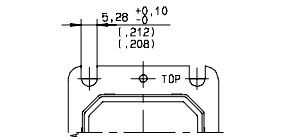
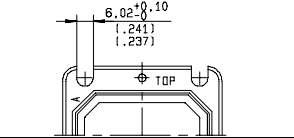
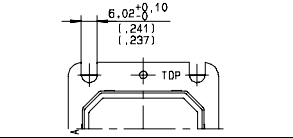
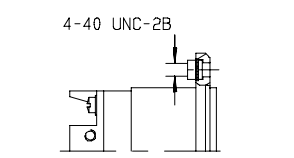
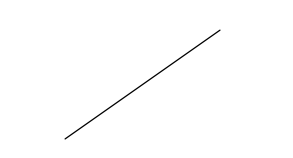
CODE	RECEPTACLE SHELL	PLUG SHELL
00		
01		
02		
03		
04		
05		
08		
12		
13		
17		

CODE	RECEPTACLE SHELL	PLUG SHELL
18	<p>4-40 UNC-2B</p>	
19	<p>4-40 UNC-2B</p>	
22	<p>$\varnothing 3.1$ (.122) DIA</p>	<p>$\varnothing 3.1$ (.122) DIA</p>
23	<p>$\varnothing 3.1$ (.122) DIA</p>	<p>$\varnothing 3.1$ (.122) DIA</p>
24	<p>(.212) DIA, $\varnothing 5.28$ $\begin{matrix} +0.10 \\ -.00 \end{matrix}$</p>	<p>(.212) DIA, $\varnothing 5.28$ $\begin{matrix} +0.10 \\ -.00 \end{matrix}$</p>
26	<p>$\varnothing 3.1$ (.122) DIA</p> <p>90°</p>	
33	<p>$\varnothing 3.1$ (.122) DIA</p>	<p>$\varnothing 3.1$ (.122) DIA</p>
34	<p>4.50 (.177) 4.15 (.163) JEU TOTAL 1.13/0.93 TOTAL PLAY .045/.037 $\varnothing 6.40$ (.252) DIA. 6.20 (.244) DIA. 0.28 (.011) 0.13 (.005) $\varnothing 3.20$ (.126) DIA. 3.10 (.122) DIA.</p>	<p>4.50 (.177) 4.15 (.163) JEU TOTAL 1.13/0.93 TOTAL PLAY .045/.037 $\varnothing 6.40$ (.252) DIA. 6.20 (.244) DIA. 0.28 (.011) 0.13 (.005) $\varnothing 3.20$ (.126) DIA. 3.10 (.122) DIA.</p>
35	<p>4.50 (.177) 4.15 (.163) 0.28 (.011) 0.13 (.005) JEU TOTAL 1.13/0.93 TOTAL PLAY .045/.037 $\varnothing 6.40$ (.252) DIA. 6.20 (.244) DIA. THREADED M 2.50 (DIA.)</p>	<p>4.50 (.177) 4.15 (.163) 0.28 (.011) 0.13 (.005) JEU TOTAL 1.13/0.93 TOTAL PLAY .045/.037 $\varnothing 6.40$ (.252) DIA. 6.20 (.244) DIA. THREADED M 2.50 (DIA.)</p>
36	<p>4.50 (.177) 4.15 (.163) 0.28 (.011) 0.13 (.005) JEU TOTAL 1.13/0.93 TOTAL PLAY .045/.037 $\varnothing 6.40$ (.252) DIA. 6.20 (.244) DIA. THREADED M 2.50 (DIA.)</p>	<p>4.50 (.177) 4.15 (.163) 0.28 (.011) 0.13 (.005) JEU TOTAL 1.13/0.93 TOTAL PLAY .045/.037 $\varnothing 6.40$ (.252) DIA. 6.20 (.244) DIA. THREADED M 2.50 (DIA.)</p>

CODE	RECEPTACLE SHELL		PLUG SHELL	
55				
				Sizes 1, 2 & 3 : spring loaded shell 6 places
60	nickel plated shell Ø 3.1 (.122) DIA	Similar to modification code 00 except that the shell, keys and keys retention plate are nickel plated	nickel plated shell Ø 3.1 (.122) DIA c'sunk 90°	Similar to modification code 00 except that the shell is nickel plated
61	nickel plated shell Ø 3.1 (.122) DIA	Similar to modification code 22 except that the shell, keys and keys retention plate are nickel plated	nickel plated shell Ø 3.1 (.122) DIA	Similar to modification code 22 except that the shell is nickel plated
62	nickel plated shell Ø 3.1 (.122) DIA	Similar to modification code 02 except that the shell, keys and keys retention plate are nickel plated	nickel plated shell Ø 3.1 (.122) DIA c'sunk 90°	Similar to modification code 02 except that the shell is nickel plated
63	nickel plated shell Ø 3.1 (.122) DIA	Similar to modification code 23 except that the shell, keys and keys retention plate are nickel plated	nickel plated shell Ø 3.1 (.122) DIA	Similar to modification code 23 except that the shell is nickel plated
64	Ø 3.1 (.122) DIA nickel plated shell	Similar to modification code 03 except that the shell, keys and keys retention plate are nickel plated	nickel plated shell Ø 3.1 (.122) DIA c'sunk 100°	Similar to modification code 03 except that the shell is nickel plated
66	nickel plated shell 4-40-UNC-3B	Similar to modification code 01 except that the shell, keys and keys retention plate are nickel plated	nickel plated shell Ø 3.1 (.122) DIA c'sunk 90°	Similar to modification code 01 except that the shell is nickel plated
67	Ø 3,08 ^{+0,10} ₋₀ (.125) (.121) DIA. nickel plated shell	Sizes 1 & 2 : 4 holes .120 (3.1) c'sunk 100° plus attaching tabs for RADIALL junction shell Size 3 : 6 holes .120 (3.1) c'sunk 100° plus attaching tabs for RADIALL junction shell	Ø 3,08 ^{+0,10} ₋₀ (.125) (.121) DIA. nickel plated shell	Sizes 1 & 2 : 4 holes .120 (3.1) c'sunk 100° plus attaching tabs for RADIALL junction shell Size 3 : 6 holes .120 (3.1) c'sunk 100° plus attaching tabs for RADIALL junction shell
73	Ø 3.1 (.122) DIA nickel plated shell	Sizes 1 & 2 : 4 holes .120 (3.1) dia c'sunk 82° Size 3 : 6 holes .120 (3.1) dia c'sunk 82° Size 4 : 10 holes .120 (3.1) dia c'sunk 82°	Ø 3.1 (.122) DIA c'sunk 82°	Sizes 1 & 2 : 4 holes .120 (3.1) dia c'sunk 82° Size 3 : 6 holes .120 (3.1) dia c'sunk 82° Size 4 : 10 holes .120 (3.1) dia c'sunk 82°
77	Ø 3,08 ^{+0,10} ₋₀ (.125) (.121) DIA. nickel plated shell	Sizes 1, 2 : 4 holes .120 (3.1) dia c'sunk 82° plus attaching tabs for RADIALL junction shell Size 3 : 6 holes .120 (3.1) dia c'sunk 82° plus attaching tabs for RADIALL junction shell	Ø 3,08 ^{+0,10} ₋₀ (.125) (.121) DIA. nickel plated shell	Sizes 1, 2 : 4 holes .120 (3.1) dia c'sunk 82° plus attaching tabs for RADIALL junction shell Size 3 : 6 holes .120 (3.1) dia c'sunk 82° plus attaching tabs for RADIALL junction shell
79	M3 nickel plated shell	Sizes 1 & 2 : four M3 clinch nuts Size 3 : six M3 clinch nuts Size 4 : ten M3 clinch nuts	M3 nickel plated shell	Sizes 1 & 2 : four M3 clinch nuts Size 3 : six M3 clinch nuts Size 4 : ten M3 clinch nuts

POSITION OF POLARIZATION KEYS AND POSTS

Connectors are shown front side, with "TOP" upwards.

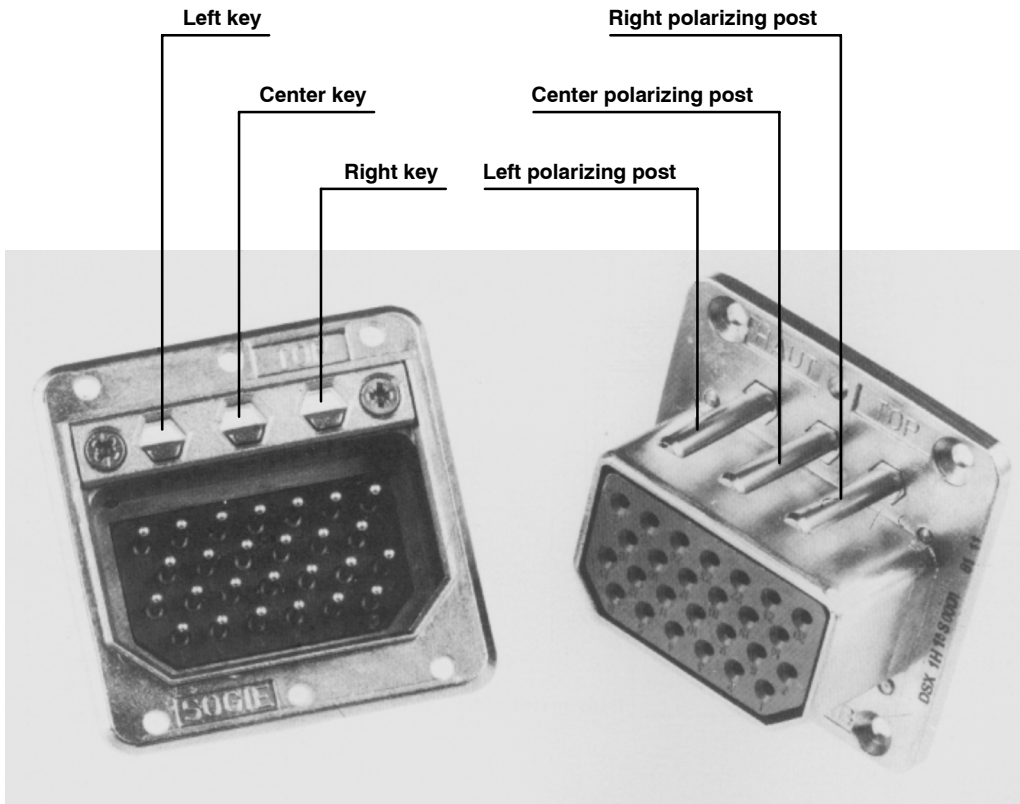

POSITION CODING

Dark area represents the polarizing post. Clear portion represents the key hole.

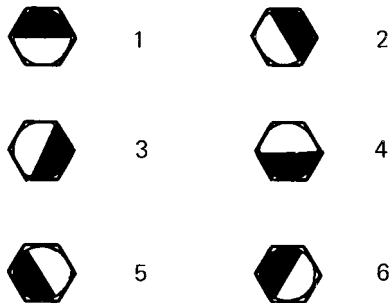

POLARIZATION CODE

(continued)

CODE NUMBER	RECEPTACLE SHELL			PLUG SHELL		
	LEFT KEY	CENTER KEY	RIGHT KEY	LEFT POST	CENTER POST	RIGHT POST
00	/	/	/	/	/	/
01	4	4	4	1	1	1
02	4	4	3	2	1	1
03	4	4	2	3	1	1
04	4	4	1	4	1	1
05	4	4	6	5	1	1
06	4	4	5	6	1	1
07	5	4	4	1	1	6
08	5	4	3	2	1	6
09	5	4	2	3	1	6
10	5	4	1	4	1	6
11	5	4	6	5	1	6
12	5	4	5	6	1	6
13	6	4	4	1	1	5
14	6	4	3	2	1	5
15	6	4	2	3	1	5
16	6	4	1	4	1	5
17	6	4	6	5	1	5
18	6	4	5	6	1	5
19	1	4	4	1	1	4
20	1	4	3	2	1	4
21	1	4	2	3	1	4
22	1	4	1	4	1	4
23	1	4	6	5	1	4
24	1	4	5	6	1	4
25	2	4	4	1	1	3
26	2	4	3	2	1	3
27	2	4	2	3	1	3
28	2	4	1	4	1	3
29	2	4	6	5	1	3
30	2	4	5	6	1	3
31	3	4	4	1	1	2
32	3	4	3	2	1	2
33	3	4	2	3	1	2
34	3	4	1	4	1	2
35	3	4	6	5	1	2
36	3	4	5	6	1	2
37	4	3	4	1	2	1
38	4	3	3	2	2	1
39	4	3	2	3	2	1
40	4	3	1	4	2	1
41	4	3	6	5	2	1
42	4	3	5	6	2	1
43	5	3	4	1	2	6
44	5	3	3	2	2	6
45	5	3	2	3	2	6
46	5	3	1	4	2	6
47	5	3	6	5	2	6
48	5	3	5	6	2	6
49	6	3	4	1	2	5
50	6	3	3	2	2	5
51	6	3	2	3	2	5
52	6	3	1	4	2	5
53	6	3	6	5	2	5
54	6	3	5	6	2	5
55	1	3	4	1	2	4
56	1	3	3	2	2	4
57	1	3	2	3	2	4
58	1	3	1	4	2	4
59	1	3	6	5	2	4
60	1	3	5	6	2	4
61	2	3	4	1	2	3
62	2	3	3	2	2	3
63	2	3	2	3	2	3
64	2	3	1	4	2	3

CODE NUMBER	RECEPTACLE SHELL			PLUG SHELL		
	LEFT KEY	CENTER KEY	RIGHT KEY	LEFT POST	CENTER POST	RIGHT POST
65	2	3	6	5	2	3
66	2	3	5	6	2	3
67	3	3	4	1	2	2
68	3	3	3	2	2	2
69	3	3	2	3	2	2
70	3	3	1	4	2	2
71	3	3	6	5	2	2
72	3	3	5	6	2	2
73	4	2	4	1	3	1
74	4	2	3	2	3	1
75	4	2	2	3	3	1
76	4	2	1	4	3	1
77	4	2	6	5	3	1
78	4	2	5	6	3	1
79	5	2	4	1	3	6
80	5	2	3	2	3	6
81	5	2	2	3	3	6
82	5	2	1	4	3	6
83	5	2	6	5	3	6
84	5	2	5	6	3	6
85	6	2	4	1	3	5
86	6	2	3	2	3	5
87	6	2	2	3	3	5
88	6	2	1	4	3	5
89	6	2	6	5	3	5
90	6	2	5	6	3	5
91	1	2	4	1	3	4
92	1	2	3	2	3	4
93	1	2	2	3	3	4
94	1	2	1	4	3	4
95	1	2	6	5	3	4
96	1	2	5	6	3	4
97	2	2	4	1	3	3
98	2	2	3	2	3	3
99	2	2	2	3	3	3
100	2	2	1	4	3	3
101	2	2	6	5	3	3
102	2	2	5	6	3	3
103	3	2	4	1	3	2
104	3	2	3	2	3	2
105	3	2	2	3	3	2
106	3	2	1	4	3	2
107	3	2	6	5	3	2
108	3	2	5	6	3	2
109	4	1	4	1	4	1
110	4	1	3	2	4	1
111	4	1	2	3	4	1
112	4	1	1	4	4	1
113	4	1	6	5	4	1
114	4	1	5	6	4	1
115	5	1	4	1	4	6
116	5	1	3	2	4	6
117	5	1	2	3	4	6
118	5	1	1	4	4	6
119	5	1	6	5	4	6
120	5	1	5	6	4	6
121	6	1	4	1	4	5
122	6	1	3	2	4	5
123	6	1	2	3	4	5
124	6	1	1	4	4	5
125	6	1	6	5	4	5
126	6	1	5	6	4	5
127	1	1	4	1	4	4
128	1	1	3	2	4	4
129	1	1	2	3	4	4

POLARIZATION CODE

(continued)

CODE NUMBER	RECEPTACLE SHELL			PLUG SHELL		
	LEFT KEY	CENTER KEY	RIGHT KEY	LEFT POST	CENTER POST	RIGHT POST
130	1	1	1	4	4	4
131	1	1	6	5	4	4
132	1	1	5	6	4	4
133	2	1	4	1	4	3
134	2	1	3	2	4	3
135	2	1	2	3	4	3
136	2	1	1	4	4	3
137	2	1	6	5	4	3
138	2	1	5	6	4	3
139	3	1	4	1	4	2
140	3	1	3	2	4	2
141	3	1	2	3	4	2
142	3	1	1	4	4	2
143	3	1	6	5	4	2
144	3	1	5	6	4	2
145	4	6	4	1	5	1
146	4	6	3	2	5	1
147	4	6	2	3	5	1
148	4	6	1	4	5	1
149	4	6	6	5	5	1
150	4	6	5	6	5	1
151	5	6	4	1	5	6
152	5	6	3	2	5	6
153	5	6	2	3	5	6
154	5	6	1	4	5	6
155	5	6	6	5	5	6
156	5	6	5	6	5	6
157	6	6	4	1	5	5
158	6	6	3	2	5	5
159	6	6	2	3	5	5
160	6	6	1	4	5	5
161	6	6	6	5	5	5
162	6	6	5	6	5	5
163	1	6	4	1	5	4
164	1	6	3	2	5	4
165	1	6	2	3	5	4
166	1	6	1	4	5	4
167	1	6	6	5	5	4
168	1	6	5	6	5	4
169	2	6	4	1	5	3
170	2	6	3	2	5	3
171	2	6	2	3	5	3
172	2	6	1	4	5	3
173	2	6	6	5	5	3

CODE NUMBER	RECEPTACLE SHELL			PLUG SHELL		
	LEFT KEY	CENTER KEY	RIGHT KEY	LEFT POST	CENTER POST	RIGHT POST
174	2	6	5	6	5	3
175	3	6	4	1	5	2
176	3	6	3	2	5	2
177	3	6	2	3	5	2
178	3	6	1	4	5	2
179	3	6	6	5	5	2
180	3	6	5	6	5	2
181	4	5	4	1	6	1
182	4	5	3	2	6	1
183	4	5	2	3	6	1
184	4	5	1	4	6	1
185	4	5	6	5	6	1
186	4	5	5	6	6	1
187	5	5	4	1	6	6
188	5	5	3	2	6	6
189	5	5	2	3	6	6
190	5	5	1	4	6	6
191	5	5	6	5	6	6
192	5	5	5	6	6	6
193	6	5	4	1	6	5
194	6	5	3	2	6	5
195	6	5	2	3	6	5
196	6	5	1	4	6	5
197	6	5	6	5	6	5
198	6	5	5	6	6	5
199	1	5	4	1	6	4
200	1	5	3	2	6	4
201	1	5	2	3	6	4
202	1	5	1	4	6	4
203	1	5	6	5	6	4
204	1	5	5	6	6	4
205	2	5	4	1	6	3
206	2	5	3	2	6	3
207	2	5	2	3	6	3
208	2	5	1	4	6	3
209	2	5	6	5	6	3
210	2	5	5	6	6	3
211	3	5	4	1	6	2
212	3	5	3	2	6	2
213	3	5	2	3	6	2
214	3	5	1	4	6	2
215	3	5	6	5	6	2
216	3	5	5	6	6	2

SEALING PLUGS AND FILLER PLUGS

Filler plugs are used in non environmental connectors and sealing plugs are used in environmental connectors. Sealing plugs and filler plugs are made of PTFE.

	SEALING PLUGS	FILLER PLUGS
size 22 (black)	616910	620920
size 20HD (red)	616911	610941
size 16 (blue)	616912	620922
size 12 (yellow)	616913	616923
size 5 (white)	see sealing boots below	620924, 616923 (note 1) or 616917 (note 2) for pin contact cavity. 620925 for socket contact cavity.
size 9 (white)	see sealing boots below	616915 (note 2)

Note :

- 1 **616923** is made of aluminum and is nickel plated.
- 2 **616917** and **616915** are providing interfacial sealing on class T connectors.

SEALING BOOTS

The sealing boots of table 1 below are to be used in size 5 contact cavities of all inserts having size 5 contact cavities except 36C7 and 36T7 inserts which use the sealing bushing plus one of the sealing sleeves of table 2. Sealing boots and sealing sleeves are made of fluorinated silicon rubber. 925.05.590 sealing bushing is made of PEI and 616914010 is made of PTFE.

Table 1



CABLE	X dia inch (mm)	P/N	DRAWING
RG58 and 142	.169 (4.3)	925-05-490	
RG 174	.079 (2.0)	925-05-470	
RG 178	.055 (1.4)	925-05-460	
RG 180	.122 (3.1)	925-05-480	
/	0	925-05-450	

Table 2

CABLE	X dia inch (mm)	SEALING BUSHING	SEALING SLEEVE	DRAWING
RG58, RG141, RG142, RG223, KX15, KX23	.185 (4.7)	925-05-590	925-05-591	
RG174, RG179, RG187, RG188, RG316, KX22, UT.085	.085 (2.15)		925-05-593	
RG178, RG196	.059 (1.5)		925-05-594	
RG180, RG195, UT.141	.120 (3.05)		925-05-592	
/	0	616914010		

DUST CAPS

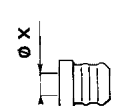
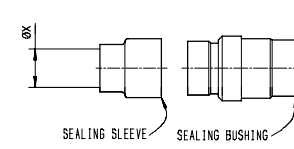
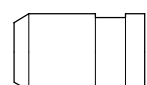
Conductive dust caps are made of thermoplastic and non conductive ones are made of polyethylene.

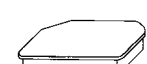
	CONDUCTIVE (black)	NON CONDUCTIVE (red)	DRAWING
PLUG	610804	610803	
RECEPTACLE	610806	610805	

JUNCTION SHELLS

Junction shells are made of aluminum alloy and are available in two kinds of finish : yellow anodized or nickel plated. The following junction shells are only for use on MIL-C-81659B and ARINC 404 shell type B connectors which have the following modification codes (see pages 18 to 20) 02 - 04 - 17 - 19 - 22 - 36 - 61 - 62 - 67 - 77.

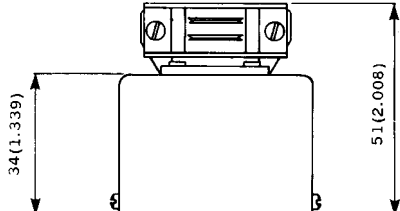
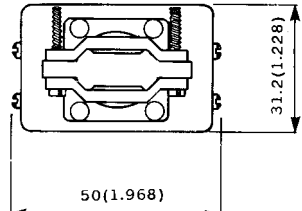
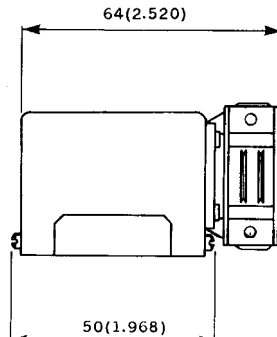
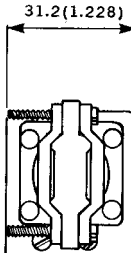
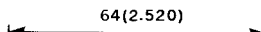
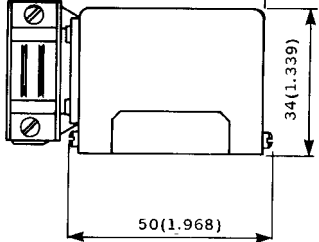
ENTRY TYPE	PLATING	P/N	DRAWING
TOP ENTRY	YELLOW ANODIZED	610902	
	NICKEL	610906	
RIGHT ENTRY	YELLOW ANODIZED	610900	
	NICKEL	610910	
LEFT ENTRY	YELLOW ANODIZED	610901	
	NICKEL	610911	

SHELL SIZE 1 NON ENVIRONMENTAL (without grommet seal)

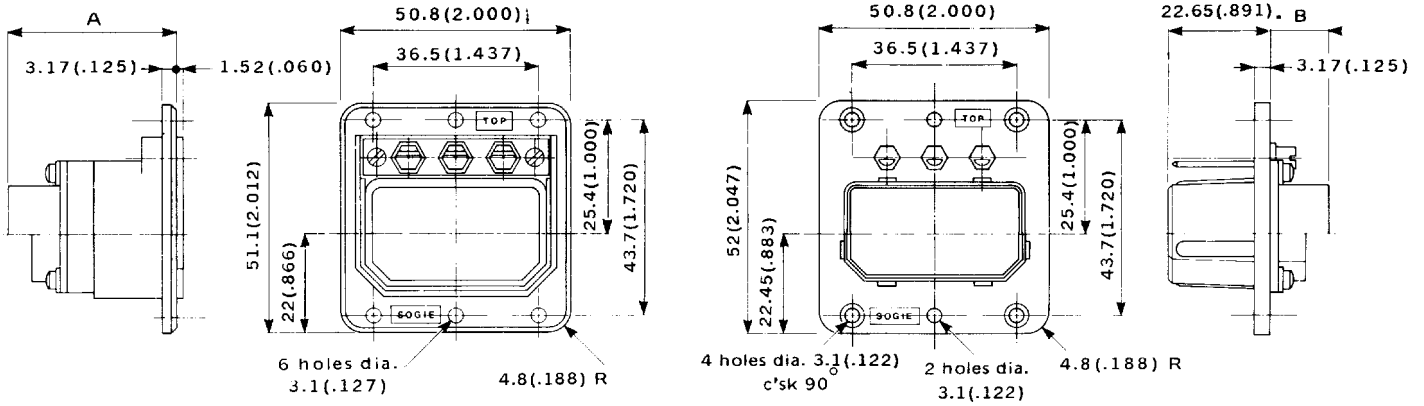

MAX. DIMENSION	ALL CRIMP CONTACT ARRANGEMENTS EXCEPT 106	CONTACT ARRANGEMENTS 106	ARRANGEMENTS WITH COAX CONTACTS SIZE 1 & 3	CONTACT ARRANGEMENTS 36C7 & 36T7	ARRANGEMENTS WITH COAX CONTACTS SIZE 5 & 9 except 36C7
A	1.260 (32)	1.015 (25.8)	1.057 (26.85)	1.122 (28.5)	1.472 (37.4)
B	.311 (7.9)	.074 (1.9)	.118 (3)	.309 (7.85)	.531 (13.5)

SHELL SIZE 1 ENVIRONMENTAL (with grommet seal)

MAX. DIMENSION	ALL CONTACT ARRANGEMENTS EXCEPT MC2 - MC3 - 106	CONTACT ARRANGEMENTS 106
A	1.515 (38.5)	1.319 (33.5)
B	.599 (14.2)	.374 (9.5)

Note : For special connectors, consult Radiall.

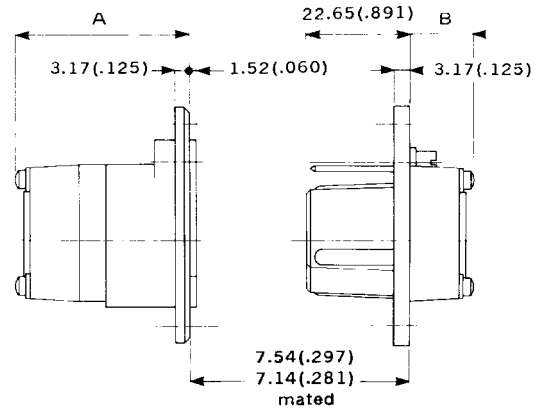

SHELL SIZE 2 NON ENVIRONMENTAL (without grommet seal)

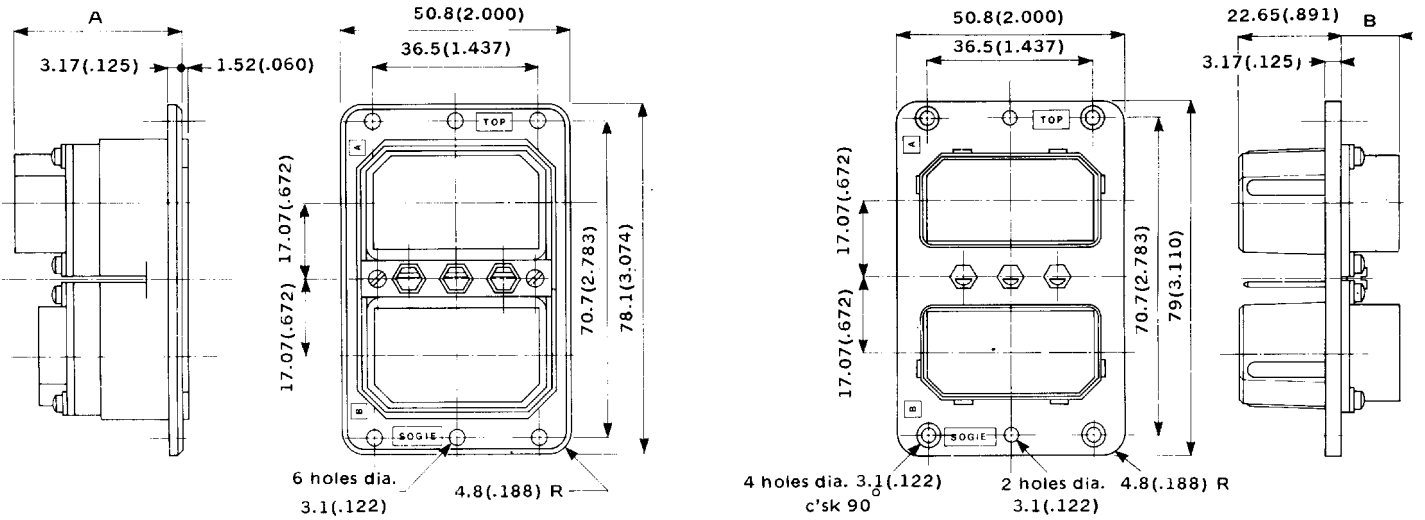

MAX. DIMENSION	ALL CRIMP CONTACT ARRANGEMENTS EXCEPT 106	CONTACT ARRANGEMENTS 106	ARRANGEMENTS WITH COAX CONTACTS SIZE 1 & 3	CONTACT ARRANGEMENTS 36C7 & 36T7	ARRANGEMENTS WITH COAX CONTACTS SIZE 5 & 9 except 36C7
A	1.260 (32)	1.015 (25.8)	1.057 (26.85)	1.122 (28.5)	1.472 (37.4)
B	.311 (7.9)	.074 (1.9)	.118 (3)	.309 (7.85)	.531 (13.5)

SHELL SIZE 2 ENVIRONMENTAL (with grommet seal)

MAX. DIMENSION	ALL CONTACT ARRANGEMENTS EXCEPT MC2 - MC3 - 106	CONTACT ARRANGEMENTS 106
A	1.515 (38.5)	1.319 (33.5)
B	.599 (14.2)	.374 (9.5)

Note : For special connectors, consult Radiall.

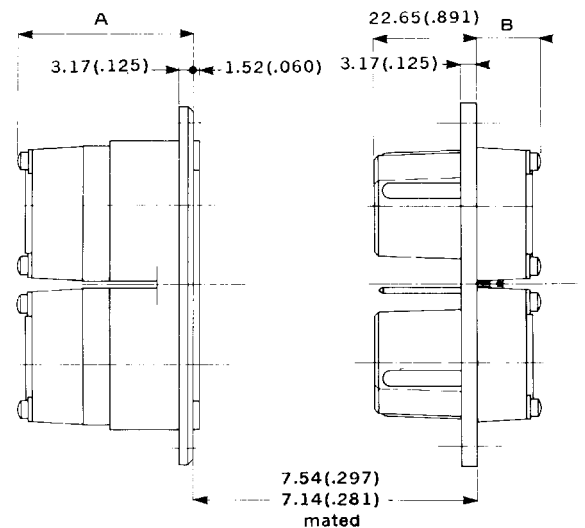

SHELL SIZE 3 NON ENVIRONMENTAL (without grommet seal)

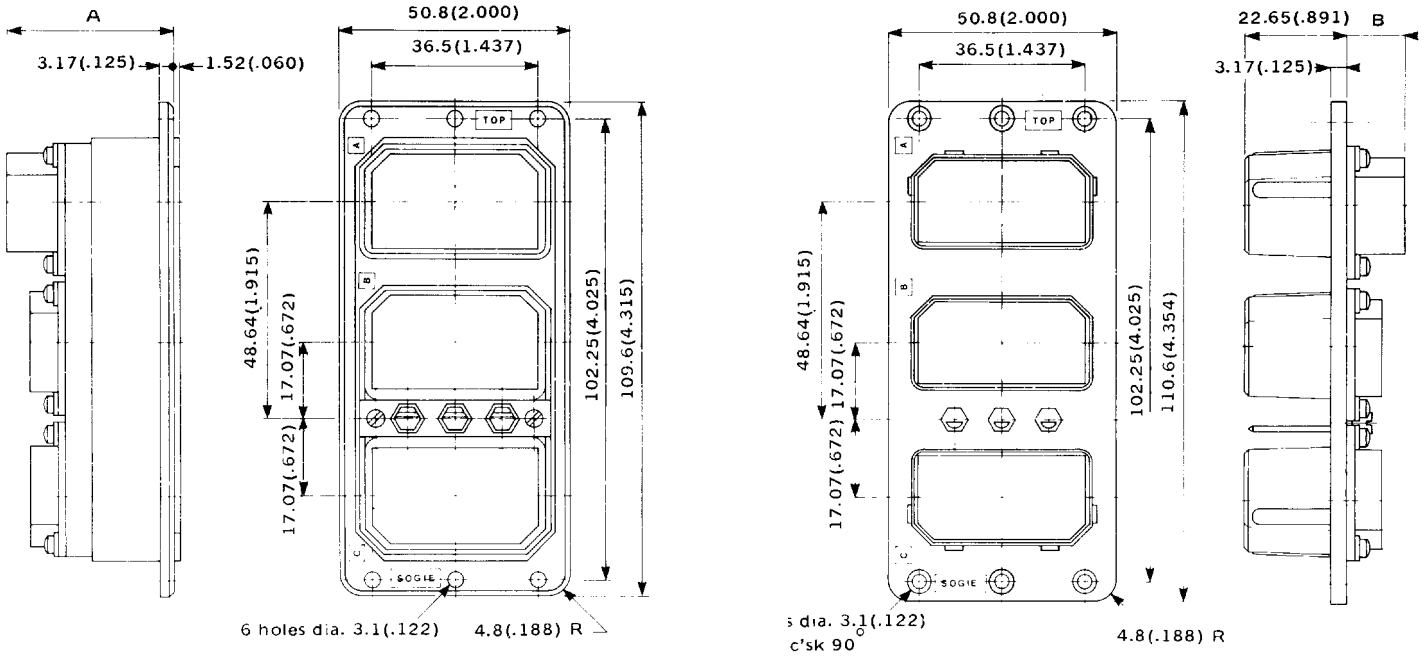

MAX. DIMENSION	ALL CRIMP CONTACT ARRANGEMENTS EXCEPT 106	CONTACT ARRANGEMENTS 106	ARRANGEMENTS WITH COAX CONTACTS SIZE 1 & 3	CONTACT ARRANGEMENTS 36C7 & 36T7	ARRANGEMENTS WITH COAX CONTACTS SIZE 5 & 9 except 36C7
A	1.260 (32)	1.015 (25.8)	1.057 (26.85)	1.122 (28.5)	1.472 (37.4)
B	.311 (7.9)	.074 (1.9)	.118 (3)	.309 (7.85)	.531 (13.5)

SHELL SIZE 3 ENVIRONMENTAL (with grommet seal)

MAX. DIMENSION	ALL CONTACT ARRANGEMENTS EXCEPT MC2 - MC3 - 106	CONTACT ARRANGEMENTS 106
A	1.515 (38.5)	1.319 (33.5)
B	.599 (14.2)	.374 (9.5)

Note : For special connectors, consult Radiall.

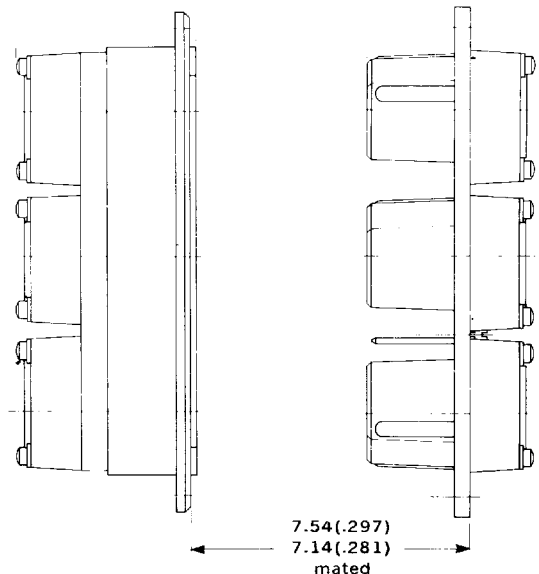

SHELL SIZE 4 NON ENVIRONMENTAL (without grommet seal)

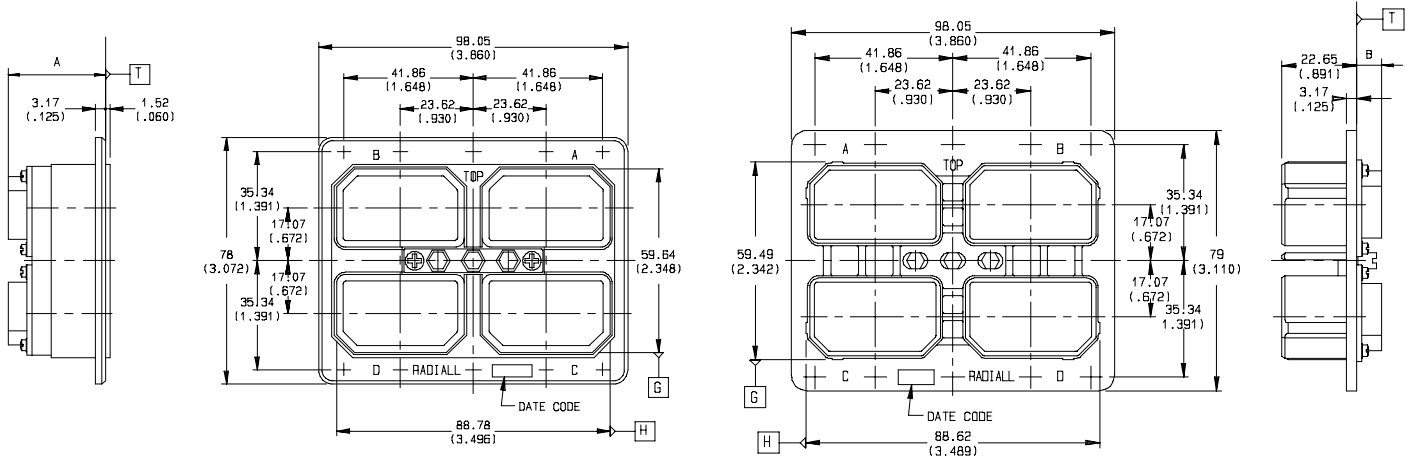

MAX. DIMENSION	ALL CRIMP CONTACT ARRANGEMENTS EXCEPT 106	CONTACT ARRANGEMENTS 106	ARRANGEMENTS WITH COAX CONTACTS SIZE 1 & 3	CONTACT ARRANGEMENTS 36C7 & 36T7	ARRANGEMENTS WITH COAX CONTACTS SIZE 5 & 9 except 36C7
A	1.260 (32)	1.015 (25.8)	1.057 (26.85)	1.122 (28.5)	1.472 (37.4)
B	.311 (7.9)	.074 (1.9)	.118 (3)	.309 (7.85)	.531 (13.5)

SHELL SIZE 4 ENVIRONMENTAL (with grommet seal)

MAX. DIMENSION	ALL CONTACT ARRANGEMENTS EXCEPT MC2 - MC3 - 106	CONTACT ARRANGEMENTS 106
A	1.515 (38.5)	1.319 (33.5)
B	.599 (14.2)	.374 (9.5)

Note : For special connectors, consult Radiall.

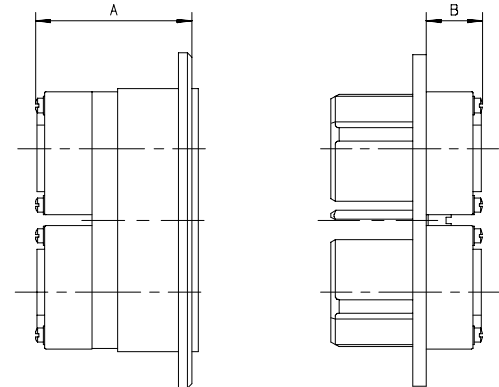

SHELL SIZE 1

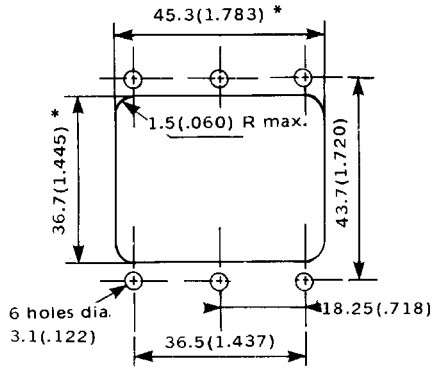

SHELL SIZE 2

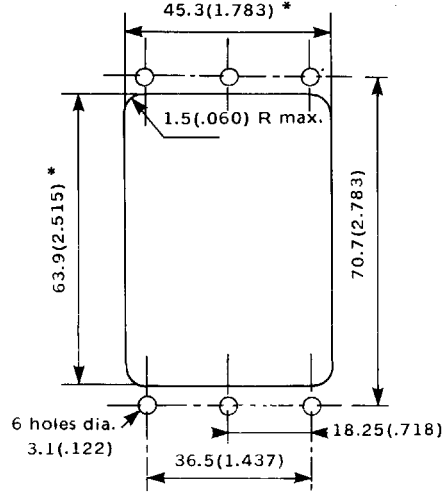

SHELL SIZE 3

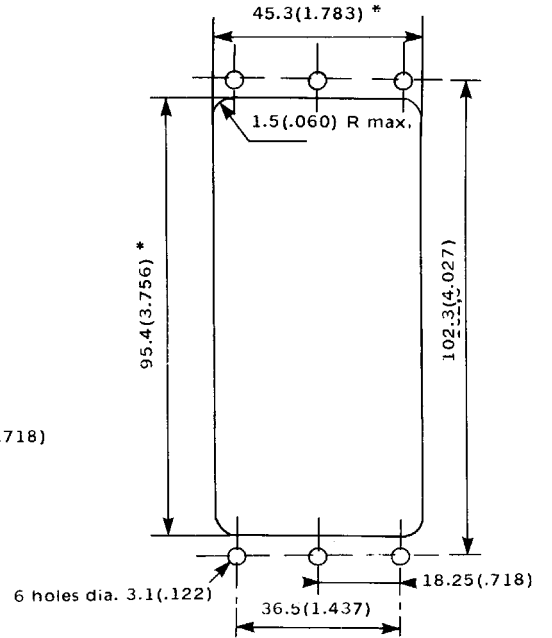

SHELL SIZE 4

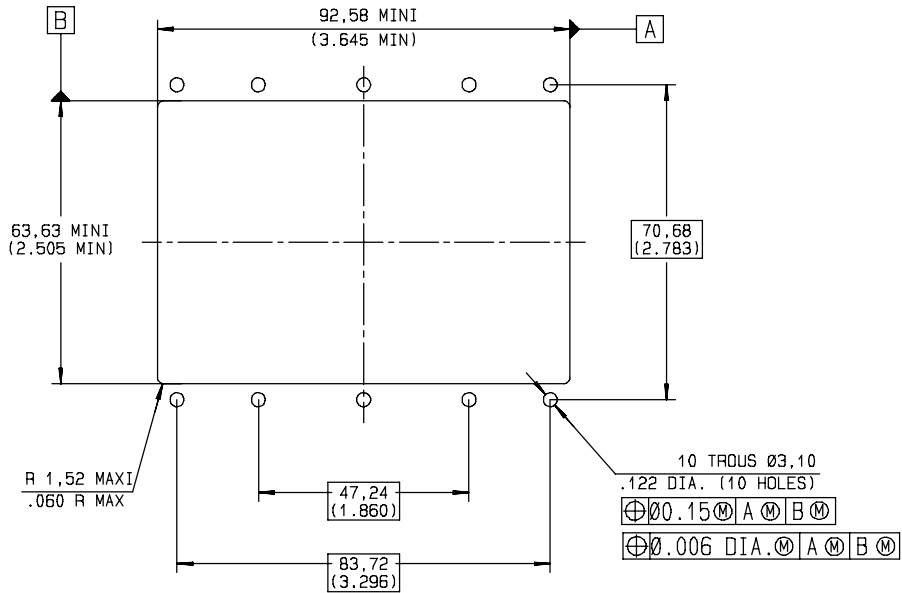

FROM MILITARY TO RADIAL P/N

MIL PART NUMBER	RADIAL PART NUMBER
M39029/11-144	616200
M39029/11-145	616210
M39029/11-146	616230
M39029/11-147	616240
M39029/12-148	616300
M39029/12-149	616310
M39029/12-150	616330
M39029/12-151	616340
M81659/29A2-0002	DSXE1PS26S73
M81659/29A2-0010	DSXE1PS40S73
M81659/29A2-0018	DSXE1PS45S73
M81659/29A2-0026	DSXE1PS57S73
M81659/29A2-0034	DSXE1PS67S73
M81659/29A2-0041	DSXE1PS106P73
M81659/29A2-0084	DSXE1PSD8S73
M81659/29A2-0104	DSXE1PS33C4S73
M81659/29A2-0136	DSXE1PXC8S73
M81659/29A2-0140	DSXE1PS32C2S73
M81659/29A2-0142	DSXE1PS40C1S73
M81659/29A2-0150	DSXE1PS32C4S73
M81659/31A2-0001	DSXE1RS26P00
M81659/31A2-0009	DSXE1RS40P00
M81659/31A2-0017	DSXE1RS45P00
M81659/31A2-0025	DSXE1RS57P00
M81659/31A2-0035	DSXE1RS67P00
M81659/31A2-0042	DSXE1RS106S00
M81659/31A2-0083	DSXE1RSD8P00
M81659/31A2-0103	DSXE1R33C4P00
M81659/31A2-0139	DSXE1RS32C2P00
M81659/31A2-0141	DSXE1RS40C1P00
M81659/31A2-0149	DSXE1R32C4P00
M81659/33A2-0004	DSXE2PS26SS26S73
M81659/33A2-0012	DSXE2PS40SS40S73
M81659/33A2-0020	DSXE2PS45SS45S73
M81659/33A2-0028	DSXE2PS57SS57S73
M81659/33A2-0036	DSXE2PS67SS67S73
M81659/33A2-0043	DSXE2PS106PS106P73
M81659/33A2-0058	DSXE2PS106PS26S73
M81659/33A2-0060	DSXE2PS26SS106P73
M81659/33A2-0072	DSXE2PS67SS106P73
M81659/33A2-0088	DSXE2PS106PXC8S73
M81659/33A2-0090	DSXE2PS106PS67S73
M81659/33A2-0106	DSXE2PS33C4SS106P73
M81659/33A2-0108	DSXE2PS33C4SXC8S73
M81659/33A2-0110	DSXE2PXM2SS40C1S73
M81659/33A2-0112	DSXE2PXM2SS57S73
M81659/33A2-0114	DSXE2PXM3SS67S73
M81659/33A2-0116	DSXE2PXM3SS106P73
M81659/33A2-0118	DSXE2PXC8SS106P73
M81659/33A2-0122	DSXE2PS32C2SS40C1S73
M81659/33A2-0124	DSXE2PS32C2SS45S73
M81659/33A2-0126	DSXE2PS32C2SS57S73
M81659/33A2-0128	DSXE2PS32C2SS67S73

MIL PART NUMBER	RADIAL PART NUMBER
M81659/33A2-0130	DSXE2PS32C2SS106P73
M81659/33A2-0132	DSXE2PS40C1SS40C1S73
M81659/33A2-0134	DSXE2PS57SS106P73
M81659/33A2-0146	DSXE2PXC8SS57S73
M81659/33A2-0148	DSXE2PS57SS26S73
M81659/33A2-0152	DSXE2PS32C4SS106P73
M81659/33A2-0156	DSXE2PXC8SS32C4S73
M81659/33A2-0160	DSXE2PS32C4SXC8S73
M81659/35A2-0003	DSXE2RS26PS26P00
M81659/35A2-0011	DSXE2RS40PS40P00
M81659/35A2-0019	DSXE2RS45PS45P00
M81659/35A2-0027	DSXE2RS57PS57P00
M81659/35A2-0035	DSXE2RS67PS67P00
M81659/35A2-0044	DSXE2RS106SS106S00
M81659/35A2-0057	DSXE2RS106SS26P00
M81659/35A2-0059	DSXE2RS26PS106S00
M81659/35A2-0071	DSXE2RS67PS106S00
M81659/35A2-0087	DSXE2RS106SXC8P00
M81659/35A2-0089	DSXE2RS106SS67P00
M81659/35A2-0105	DSXE2RS33C4PS106S00
M81659/35A2-0107	DSXE2RS33C4PXC8P00
M81659/35A2-0109	DSXE2RXMC2PS40C1P00
M81659/35A2-0111	DSXE2RXMC2PS57P00
M81659/35A2-0113	DSXE2RXMC3PS67P00
M81659/35A2-0115	DSXE2RXMC3PS106S00
M81659/35A2-0117	DSXE2RXC8PS106S00
M81659/35A2-0121	DSXE2RS32C2PS40C1P00
M81659/35A2-0123	DSXE2RS32C2PS45P00
M81659/35A2-0125	DSXE2RS32C2PS57P00
M81659/35A2-0127	DSXE2RS32C2PS67P00
M81659/35A2-0129	DSXE2RS32C2PS106S00
M81659/35A2-0131	DSXE2RS40C1PS40C1P00
M81659/35A2-0133	DSXE2RS57PS106S00
M81659/35A2-0145	DSXE2RXC8PS57P00
M81659/35A2-0147	DSXE2RS57PS26P00
M81659/35A2-0151	DSXE2RS32C4PS106S00
M81659/35A2-0155	DSXE2RXC8PS32C4P00
M81659/35A2-0159	DSXE2RS32C4PXC8P00
M81659/37A2-0006	DSXE3PS26SS26SS26S73
M81659/37A2-0014	DSXE3PS40SS40SS40S73
M81659/37A2-0022	DSXE3PS45SS45SS45S73
M81659/37A2-0030	DSXE3PS57SS57SS57S73
M81659/37A2-0038	DSXE3PS67SS67SS67S73
M81659/37A2-0045	DSXE3PS106PS106PS106P73
M81659/37A2-0066	DSXE3PXC8SXC8SXC8S73
M81659/37A2-0068	DSXE3PXC8SXC8SS106P73
M81659/37A2-0074	DSXE3PS67SS67SXC8S73
M81659/37A2-0076	DSXE3PS67SS67SS106P73
M81659/37A2-0080	DSXE3PS67SS106PS67S73
M81659/37A2-0092	DSXE3PS106PS106PS67S73
M81659/37A2-0158	DSXE3PS106PS106PS32C4S73
M81659/39A2-0005	DSXE3RS26PS26PS26P01
M81659/39A2-0013	DSXE3RS40PS40PS40P01

FROM MILITARY TO RADIAL P/N

MIL PART NUMBER	RADIALL PART NUMBER
M81659/39A2-0021	DSXE3RS45PS45PS45P01
M81659/39A2-0029	DSXE3RS57PS57PS57P01
M81659/39A2-0037	DSXE3RS67PS67PS67P01
M81659/39A2-0046	DSXE3RS106SS106SS106S01
M81659/39A2-0065	DSXE3RXC8PXC8PXC8P01
M81659/39A2-0067	DSXE3RXC8PXC8PS106S01
M81659/39A2-0073	DSXE3RS67PS67PXC8P01
M81659/39A2-0075	DSXE3RS67PS67PS106S01
M81659/39A2-0079	DSXE3RS67PS106SS67P01
M81659/39A2-0091	DSXE3RS106SS106SS67P01
M81659/39A2-0157	DSXE3RS106SS106SS32C4P01
M81659/41A2-0008	DSXE4PS26SS26SS26SS26S73
M81659/41A2-0016	DSXE4PS40SS40SS40SS40S73
M81659/41A2-0024	DSXE4PS45SS45SS45SS45S73
M81659/41A2-0032	DSXE4PS57SS57SS57SS57S73
M81659/41A2-0040	DSXE4PS67SS67SS67SS67S73
M81659/41A2-0047	DSXE4PS106PS106PS106PS106P73
M81659/41A2-0082	DSXE4PS67SS67SS33C4SS33C4S73
M81659/41A2-0086	DSXE4PSC8SSC8SS67SS67S73
M81659/41A2-0098	DSXE4PS106PS67SS106PSC8S73
M81659/41A2-0100	DSXE4PS106PS67SSC8SSC8S73
M81659/41A2-0102	DSXE4PS106PS106PS67SS67S73
M81659/43A2-0007	DSXE4RS26PS26PS26PS26P00
M81659/43A2-0015	DSXE4RS40PS40PS40PS40P00
M81659/43A2-0023	DSXE4RS45PS45PS45PS45P00
M81659/43A2-0031	DSXE4RS57PS57PS57PS57P00
M81659/43A2-0039	DSXE4RS67PS67PS67PS67P00
M81659/43A2-0048	DSXE4RS106SS106SS106SS106S00
M81659/43A2-0061	DSXE4RS26PS26PS26S00
M81659/43A2-0085	DSXE4RSC8PSC8PSC8PSC8P00
M81659/43A2-0095	DSXE4RS106SSC8PS106SS106S00
M81659/43A2-0097	DSXE4RS106SS67PS106SSC8P00
M81659/43A2-0099	DSXE4RS106SS67PSC8PSC8P00
M81659/43A2-0101	DSXE4RS106SS106SS67PS67P00
M81659/61A2-0001	DSXT1RS26P00
M81659/61A2-0009	DSXT1RS40P00
M81659/61A2-0017	DSXT1RS45P00
M81659/61A2-0025	DSXT1RS57P00
M81659/61A2-0033	DSXT1RS67P00
M81659/61A2-0042	DSXT1RS106S00
M81659/61A2-0083	DSXT1RSD8P00
M81659/61A2-0103	DSXT1RS33C4P00
M81659/61A2-0135	DSXT1RXC8P00
M81659/61A2-0139	DSXT1RS32C2P00
M81659/61A2-0141	DSXT1RS40C1P00
M81659/61A2-0149	DSXT1RS32C4P00
M81659/62A2-0003	DSXT2RS26PS26P00
M81659/62A2-0011	DSXT2RS40PS40P00
M81659/62A2-0019	DSXT2RS45PS45P00
M81659/62A2-0027	DSXT2RS57PS57P00
M81659/62A2-0035	DSXT2RS67PS67P00
M81659/62A2-0044	DSXT2RS106SS106S00
M81659/62A2-0057	DSXT2RS106SS26P00

MIL PART NUMBER	RADIALL PART NUMBER
M81659/62A2-0059	DSXT2RS26PS106S00
M81659/62A2-0071	DSXT2RS67PS106S00
M81659/62A2-0087	DSXT2RS106SXC8P00
M81659/62A2-0089	DSXT2RS106SS67P00
M81659/62A2-0105	DSXT2RS33C4PS106S
M81659/62A2-0107	DSXT2RS33C4PXC8P00
M81659/62A2-0109	DSXT2RXC2PS40C1P00
M81659/62A2-0111	DSXT2RXC2PS57P00
M81659/62A2-0113	DSXT2RXC3PS67P00
M81659/62A2-0115	DSXT2RXC3PS106S00
M81659/62A2-0117	DSXT2RXC8PS106S00
M81659/62A2-0121	DSXT2RS32C2PS40C1P00
M81659/62A2-0123	DSXT2RS32C2PS45P00
M81659/62A2-0125	DSXT2RS32C2PS57P00
M81659/62A2-0127	DSXT2RS32C2PS67P00
M81659/62A2-0129	DSXT2RS32C2PS106S00
M81659/62A2-0131	DSXT2RS40C1PS40C1P00
M81659/62A2-0133	DSXT2RS57PS106S00
M81659/62A2-0145	DSXT2RXC8PS57P00
M81659/62A2-0147	DSXT2RS57PS26P00
M81659/62A2-0151	DSXT2RS32C4PS106S00
M81659/62A2-0155	DSXT2RXC8PS32C4P00
M81659/62A2-0159	DSXT2RS32C4PXC8P00
M81659/63A2-0005	DSXT3RS26PS26PS26P00
M81659/63A2-0013	DSXT3RS40PS40PS40P00
M81659/63A2-0021	DSXT3RS45PS45PS45P00
M81659/63A2-0029	DSXT3RS57PS57PS57P00
M81659/63A2-0037	DSXT3RS67PS67PS67P00
M81659/63A2-0046	DSXT3RS106SS106SS106S00
M81659/63A2-0065	DSXT3RXC8PXC8PXC8P00
M81659/63A2-0067	DSXT3RXC8PXC8PS106S00
M81659/63A2-0073	DSXT3RS67PS67PXC8P00
M81659/63A2-0075	DSXT3RS67PS67PS106S00
M81659/63A2-0079	DSXT3RS67PS106SS67P00
M81659/63A2-0091	DSXT3RS106SS106SS67P00
M81659/63A2-0157	DSXT3RS106SS106SS32C4P00
M81659/64A2-0007	DSXT4RS26PS26PS26PS26P00
M81659/64A2-0015	DSXT4RS40PS40PS40PS40P00
M81659/64A2-0023	DSXT4RS45PS45PS45PS45P00
M81659/64A2-0031	DSXT4RS57PS57PS57PS57P00
M81659/64A2-0048	DSXT4RS106SS106SS106SS106S00
M81659/64A2-0081	DSXT4RS67PS67PS33C4PS33C4P00
M81659/64A2-0085	DSXT4RSC8PSC8PS67PS67P00
M81659/64A2-0095	DSXT4RS106SSC8PS106SS106S00
M81659/64A2-0097	DSXT4RS106SS67PS106SSC8P00
M81659/64A2-0099	DSXT4RS106SS67PSC8PSC8P00
M81659/64A2-0101	DSXT4RS106SS106SS67PS67P00
M81659/65A2-0002	DSXN1PS26S73
M81659/65A2-0010	DSXN1PS40S73
M81659/65A2-0018	DSXN1PS45S73
M81659/65A2-0026	DSXN1PS57S73
M81659/65A2-0034	DSXN1PS67S73
M81659/65A2-0041	DSXN1PS106P73

FROM MILITARY TO RADIAL P/N

MIL PART NUMBER	RADIALL PART NUMBER
M81659/65A2-0084	DSXN1PSD8S73
M81659/65A2-0104	DSXN1PS33C4S73
M81659/65A2-0136	DSXN1PXC8S73
M81659/65A2-0140	DSXN1PS32C2S73
M81659/65A2-0142	DSXN1PS40C1S73
M81659/65A2-0150	DSXN1PS32C4S73
M81659/66A2-0001	DSXN1RS26P00
M81659/66A2-0009	DSXN1RS40P00
M81659/66A2-0017	DSXN1RS45P00
M81659/66A2-0025	DSXN1RS57P00
M81659/66A2-0033	DSXN1RS67P00
M81659/66A2-0042	DSXN1RS106S00
M81659/66A2-0083	DSXN1RSD8P00
M81659/66A2-0103	DSXN1RS33C4P00
M81659/66A2-0135	DSXN1RXC8P00
M81659/66A2-0139	DSXN1RS32C2P00
M81659/66A2-0141	DSXN1RS40C1P00
M81659/66A2-0149	DSXN1RS32C4P00
M81659/67A2-0001	DSXN1RS26P01
M81659/67A2-0009	DSXN1RS40P01
M81659/67A2-0017	DSXN1RS45P01
M81659/67A2-0025	DSXN1RS57P01
M81659/67A2-0033	DSXN1RS67P01
M81659/67A2-0042	DSXN1RS106S01
M81659/67A2-0083	DSXN1RSD8P01
M81659/67A2-0103	DSXN1RS33C4P01
M81659/67A2-0135	DSXN1RXC8P01
M81659/67A2-0139	DSXN1RS32C2P01
M81659/67A2-0141	DSXN1RS40C1P01
M81659/67A2-0149	DSXN1RS32C4P01
M81659/68A2-0001	DSXN1RS26P23
M81659/68A2-0009	DSXN1RS40P23
M81659/68A2-0017	DSXN1RS45P23
M81659/68A2-0025	DSXN1RS57P23
M81659/68A2-0033	DSXN1RS67P23
M81659/68A2-0042	DSXN1RS106S23
M81659/68A2-0083	DSXN1RSD8P23
M81659/68A2-0103	DSXN1RS33C4P23
M81659/68A2-0135	DSXN1RXC8P23
M81659/68A2-0139	DSXN1RS32C2P23
M81659/68A2-0141	DSXN1RS40C1P23
M81659/68A2-0149	DSXN1RS32C4P23
M81659/69A2-0004	DSXN2PS26SS26S73
M81659/69A2-0012	DSXN2PS40SS40S73
M81659/69A2-0020	DSXN2PS45SS45S73
M81659/69A2-0028	DSXN2PS57SS57S73
M81659/69A2-0036	DSXN2PS67SS67S73
M81659/69A2-0043	DSXN2PS106PS106P73
M81659/69A2-0058	DSXN2PS106PS26S73
M81659/69A2-0060	DSXN2PS26SS106P73
M81659/69A2-0072	DSXN2PS67SS106P73
M81659/69A2-0088	DSXN2PS106PXC8S73
M81659/69A2-0090	DSXN2PS106PS67S73

MIL PART NUMBER	RADIALL PART NUMBER
M81659/69A2-0106	DSXN2PS33C4SS106P73
M81659/69A2-0108	DSXN2PS33C4SXC8S73
M81659/69A2-0110	DSXN2PXXMC2SS40C1S73
M81659/69A2-0112	DSXN2PXXMC2SS57S73
M81659/69A2-0114	DSXN2PXXMC3SS67S73
M81659/69A2-0116	DSXN2PXXMC3SS106P73
M81659/69A2-0118	DSXN2PXC8SS106P73
M81659/69A2-0122	DSXN2PS32C2SS40C1S73
M81659/69A2-0124	DSXN2PS32C2SS45S73
M81659/69A2-0126	DSXN2PS32C2SS57S73
M81659/69A2-0128	DSXN2PS32C2SS67S73
M81659/69A2-0130	DSXN2PS32C2SS106P73
M81659/69A2-0132	DSXN2PS40C1SS40C1S73
M81659/69A2-0134	DSXN2PS57SS106P73
M81659/69A2-0146	DSXN2PXC8SS57S73
M81659/69A2-0148	DSXN2PS57SS26S73
M81659/69A2-0152	DSXN2PS32C4SS106P73
M81659/69A2-0156	DSXN2PXC8SS32C4S73
M81659/69A2-0160	DSXN2PS32C4SXC8S73
M81659/70A2-0003	DSXN2RS26PS26P00
M81659/70A2-0011	DSXN2RS40PS40P00
M81659/70A2-0019	DSXN2RS45PS45P00
M81659/70A2-0027	DSXN2RS57PS57P00
M81659/70A2-0035	DSXN2RS67PS67P00
M81659/70A2-0044	DSXN2RS106SS106S00
M81659/70A2-0057	DSXN2RS106SS26P00
M81659/70A2-0059	DSXN2RS26PS106S00
M81659/70A2-0071	DSXN2RS67PS106S00
M81659/70A2-0087	DSXN2RS106SXC8P00
M81659/70A2-0089	DSXN2RS106SS67P00
M81659/70A2-0105	DSXN2RS33C4PS106S00
M81659/70A2-0107	DSXN2RS33C4PXC8P00
M81659/70A2-0109	DSXN2RXMC2S40C1P00
M81659/70A2-0111	DSXN2RXMC2PS57P00
M81659/70A2-0113	DSXN2RXMC3PS67P00
M81659/70A2-0115	DSXN2RXMC3PS106S00
M81659/70A2-0117	DSXN2RXC8PS106S00
M81659/70A2-0121	DSXN2RS32C2PS40C1P00
M81659/70A2-0123	DSXN2RS32C2PS45P00
M81659/70A2-0125	DSXN2RS32C2PS57P00
M81659/70A2-0127	DSXN2RS32C2PS67P00
M81659/70A2-0129	DSXN2RS32C2PS106S00
M81659/70A2-0131	DSXN2RS40C1PS40C1P00
M81659/70A2-0133	DSXN2RS57PS106S00
M81659/70A2-0145	DSXN2RXC8PS57P00
M81659/70A2-0147	DSXN2RS57PS26P00
M81659/70A2-0151	DSXN2RS32C4PS106S00
M81659/70A2-0155	DSXN2RXC8PS32C4P00
M81659/70A2-0159	DSXN2RS32C4PXC8P00
M81659/71A2-0003	DSXN2RS26PS26P01
M81659/71A2-0011	DSXN2RS40PS40P01
M81659/71A2-0019	DSXN2RS45PS45P01
M81659/71A2-0027	DSXN2RS57PS57P01

(continued)

FROM MILITARY TO RADIAL P/N

MIL PART NUMBER	RADIAL PART NUMBER
M81659/71A2-0035	DSXN2RS67PS67P01
M81659/71A2-0044	DSXN2RS106SS106S01
M81659/71A2-0057	DSXN2RS106SS26P01
M81659/71A2-0059	DSXN2RS26PS106S01
M81659/71A2-0071	DSXN2RS67PS106S01
M81659/71A2-0087	DSXN2RS106SXC8P01
M81659/71A2-0089	DSXN2RS106SS67P01
M81659/71A2-0105	DSXN2RS33C4PS106S01
M81659/71A2-0107	DSXN2RS33C4PXC8P01
M81659/71A2-0109	DSXN2RXMC2PS40C1P01
M81659/71A2-0111	DSXN2RXMC2PS57P01
M81659/71A2-0113	DSXN2RXMC3PS67P01
M81659/71A2-0115	DSXN2RXMC3PS106S01
M81659/71A2-0117	DSXN2RXC8PS106S01
M81659/71A2-0121	DSXN2RS32C2PS40C1P01
M81659/71A2-0123	DSXN2RS32C2PS45P01
M81659/71A2-0125	DSXN2RS32C2PS57P01
M81659/71A2-0127	DSXN2RS32C2PS67P01
M81659/71A2-0129	DSXN2RS32C2PS106S01
M81659/71A2-0131	DSXN2RS40C1PS40C1P01
M81659/71A2-0133	DSXN2RS57PS106S01
M81659/71A2-0145	DSXN2RXC8PS57P01
M81659/71A2-0147	DSXN2RS57PS26P01
M81659/71A2-0151	DSXN2RS32C4PS106S01
M81659/71A2-0155	DSXN2RXC8PS32C4P01
M81659/71A2-0159	DSXN2RS32C4PXC8P01
M81659/72A2-0003	DSXN2RS26PS26P23
M81659/72A2-0011	DSXN2RS40PS40P23
M81659/72A2-0019	DSXN2RS45PS45P23
M81659/72A2-0027	DSXN2RS57PS57P23
M81659/72A2-0035	DSXN2RS67PS67P23
M81659/72A2-0044	DSXN2RS106SS106S23
M81659/72A2-0057	DSXN2RS106SS26P23
M81659/72A2-0059	DSXN2RS26PS106S23
M81659/72A2-0071	DSXN2RS67PS106S23
M81659/72A2-0087	DSXN2RS106SXC8P23
M81659/72A2-0089	DSXN2RS106SS67P23
M81659/72A2-0105	DSXN2RS33C4PS106S23
M81659/72A2-0107	DSXN2RS33C4PXC8P23
M81659/72A2-0109	DSXN2RXMC2PS40C1P23
M81659/72A2-0111	DSXN2RXMC2PS57P23
M81659/72A2-0113	DSXN2RXMC3PS67P23
M81659/72A2-0115	DSXN2RXMC3PS106S23
M81659/72A2-0117	DSXN2RXC8PS106S23
M81659/72A2-0121	DSXN2RS32C2PS40C1P23
M81659/72A2-0123	DSXN2RS32C2PS45P23
M81659/72A2-0125	DSXN2RS32C2PS57P23
M81659/72A2-0127	DSXN2RS32C2PS67P23
M81659/72A2-0129	DSXN2RS32C2PS106S23
M81659/72A2-0131	DSXN2RS40C1PS40C1P23
M81659/72A2-0133	DSXN2RS57PS106S23
M81659/72A2-0145	DSXN2RXC8PS57P23
M81659/72A2-0147	DSXN2RS57PS26P23

MIL PART NUMBER	RADIAL PART NUMBER
M81659/72A2-0151	DSXN2RS32C4PS106S23
M81659/72A2-0155	DSXN2RXC8PS32C4P23
M81659/72A2-0159	DSXN2RS32C4PXC8P23

DSX F 4 R Y 40 P Y40P Y26P Y45P 00 01

Series _____

Class _____
 F : front release front removable contacts, inserts without interfacial seal.
 K : front release front removable contacts, inserts with interfacial seal.

Shell size _____
 1 : one gang shell
 2 : two gang shell
 3 : three gang shell
 4 : four gang shell

Shell type _____
 R : receptacle
 P : plug

Termination style _____
 X : without contacts
 V : wire wrap 2 levels
 W : wire wrap 3 levels
 Y : PC tail

Contact arrangement _____
 (see notes 1 & 2)
 to be chosen among the following : 26 - 40 - 45 - 57 - 67 - 33C4 - 106

Contact type _____
 S : socket
 P : pin

Gang B _____

Gang C _____

Gang D _____

Modification code _____
 (see pages 18 to 20)

Polarization code _____
 (see note 3 and pages 21 to 23)

Gang A

Notes :

- 1 For mixed contact arrangements, order coax contacts separately **see contacts available on page 36**. Coax contacts are rear release rear removable.
- 2 For 33C4 and 67 contact arrangements, size 16 contacts cavities are for front release front removable contacts.
Size 16 contacts are to be ordered separately.
- 3 Without polarization code : the connector is delivered with polarizing system unassembled
 Polarization code 00 : the connector is delivered without polarizing system
 Polarization code from 01 to 216 : the connector is delivered with the polarization hardware assembled as defined by code.

CONTACTS WITH PC TAIL SIZES 22, 20HD & 16

Contacts are delivered installed in the connector.

CONTACT SIZE	CONTACT ARRANGEMENT	PIN	SOCKET	INS / EXT TOOL	DIMENSIONS	
					A	B
22	106	/	620361	282500	.234/.265 (5.95/6.75)	.023 (.6)
20HD	40-45-67-33C4-57	616220	/	282503	.169/.200 (4.3/5.1)	
16 *	26-67-33C4	616235	/	282504	.140/.170 (3.55/4.32)	.039 (1.0)
		616235010	/			
		616234	/		.400/.433 (10.20/11.00)	

Butt for printed circuit board

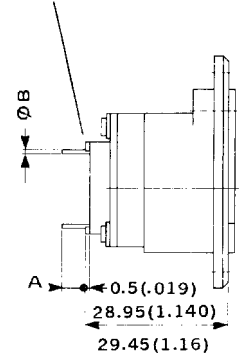

* front release front removable size 16 contacts pc tail termination are delivered installed only for 26 contact arrangement (which is fitted with 616235 contacts). For 67 and 33C4 contact arrangements front release front removable size 16 contacts must be ordered separately.

CONTACTS WITH WIRE WRAP POST SIZES 22 & 20HD

Contacts are delivered installed in the connector. For 67 and 33C4 contact arrangements, front release front removable size 16 contacts are not delivered with the connector. They must be ordered separately and chosen among size 16 PC tail contacts and 616326 size 16 solder cup contact (rear extension from insert = .173/.204 (4.4/5.2)).

CONTACT SIZE	AWG	CONTACT ARRANGEMENT	PIN	SOCKET	INS / EXT TOOL	DIMENSIONS
						A
22	26 28 30	106	/	620351 (2 wrap levels)	282500	.372/.412 (9.45/10.45)
				620352 (3 wrap levels)		.502/.541 (12.75/13.75)
20HD	26 28 30	40-45-67-33C4-57	616222 2 wrap levels	/	282503	.394/.433 (10/11)
			616224 3 wrap levels			.523/.563 (13.3/14.3)

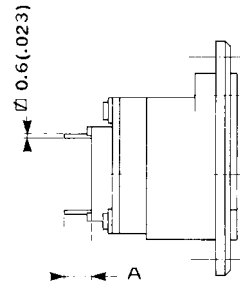

COAXIAL CRIMP CONTACTS FOR 33C4 CONTACT ARRANGEMENTS SIZE 5

These coaxial contacts are rear release rear removable and designed to be installed in 33C4 contact arrangement class F or K. They must be ordered separately.

CONTACT SIZE	CONTACT ARRANGEMENT	CABLE	PIN	SOCKET	CENTER CONTACT			OUTER BODY			WIRING INSTR.
					CRIMPING TOOL RADIALL P/N (MIL P/N)	POSITIONER RADIALL P/N (MIL P/N)	SEL.	CRIMPING TOOL RADIALL P/N (MIL P/N)	DIE RADIALL P/N (MIL P/N)	HEX.	
5	33C4	Microdot 250.39.37	616126	/	282281 (M22520/2-01)	282974	7	282293 (M22520/5-01)	282246 (M22520/5-05)	B	B1 page 57
		RG178 KX21	616127	/							

TECHNICAL CHARACTERISTICS

See pages 6 and 7

POLARIZATION CODE

See pages 21 to 23

MODIFICATION CODE

See pages 18 to 20

ACCESSORIES

See pages 24 and 25

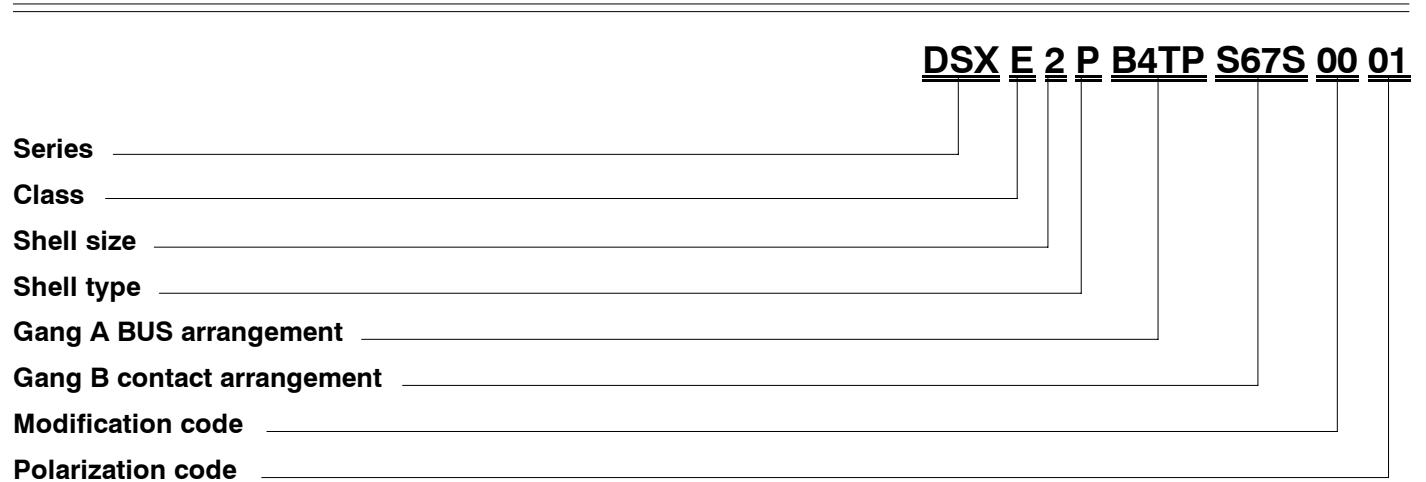

Notes : Data bus contact arrangements have no interfacial seal and no rear grommet.

TECHNICAL CHARACTERISTICS

See pages 6 and 7.

For any additional information ask for the RP2667 DSX DATA BUS to RADIALL.

PIN INSERT MATING SIDE SHOWN

B2TP1 - H2TP1

Number of contacts	Contact size	Location
2	Twinax	A, B

DWV = 1000 V ac

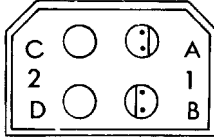

B2S1

Number of contacts	Contact size	Location
2	Twinax	A, B

DWV = 1000 V ac

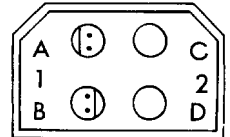

B2TP2 - H2TP2

Number of contacts	Contact size	Location
2	Twinax	C, D

DWV = 1000 V ac

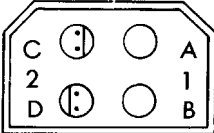

B2S2

Number of contacts	Contact size	Location
2	Twinax	C, D

DWV = 1000 V ac

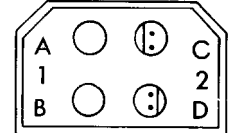

B4TP - H4TP

Number of contacts	Contact size	Location
4	Twinax	A, B, C, D

DWV = 1000 V ac

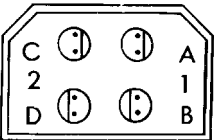

B4S

Number of contacts	Contact size	Location
4	Twinax	A, B, C, D

DWV = 1000 V ac

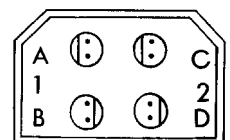

S42B2P

Number of contacts	Contact size	Location
2	Twinax	A, B
42	20HD	1 to 42

DWV = 1000 V ac

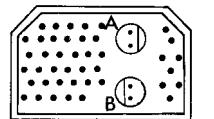

S42B2S

Number of contacts	Contact size	Location
2	Twinax	A, B
42	20HD	1 to 42

DWV = 1000 V ac

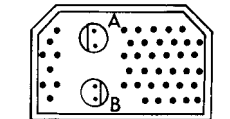

B2TP, H2TP, B4TP & H4TP AIRCRAFT CONNECTOR

The aircraft connector comprises two sub assemblies.

1 - A plug shell fitted with an insert incorporating 2 (B2TP or H2TP) or 4 (B4TP or H4TP) twinax pin contacts.

2 - one or two connection plugs depending on the number of BUS lines (B2 or B4). If there are two BUS lines (B2TP or H2TP) the two twinax contacts and the connection plug can be installed either in position 1 (B2TP1 or H2TP1) or in position 2 (B2TP2 or H2TP2).

The difference between B2TP1 and H2TP1, B2TP2 and H2TP2, B4TP and H4TP depends on the shielded twisted pairs cable that is used.

For FILECA F 2709/12 cable the designation used are B2TP1, B2TP2, B4TP.

For FILECA F 2709/9 cable the designation used are H2TP1, H2TP2, H4TP.

F2709/12 description :

Differential impedance = $75 \pm 5 \Omega$

Shielded twisted pair (each conductor = AWG 20)

Outer diameter = .206 (5.35) max.

F2709/9 description :

Differential impedance = $75 \pm 5 \Omega$

Shielded twisted pair (each conductor = AWG 22)

Outer diameter = .189 (4.80) max.

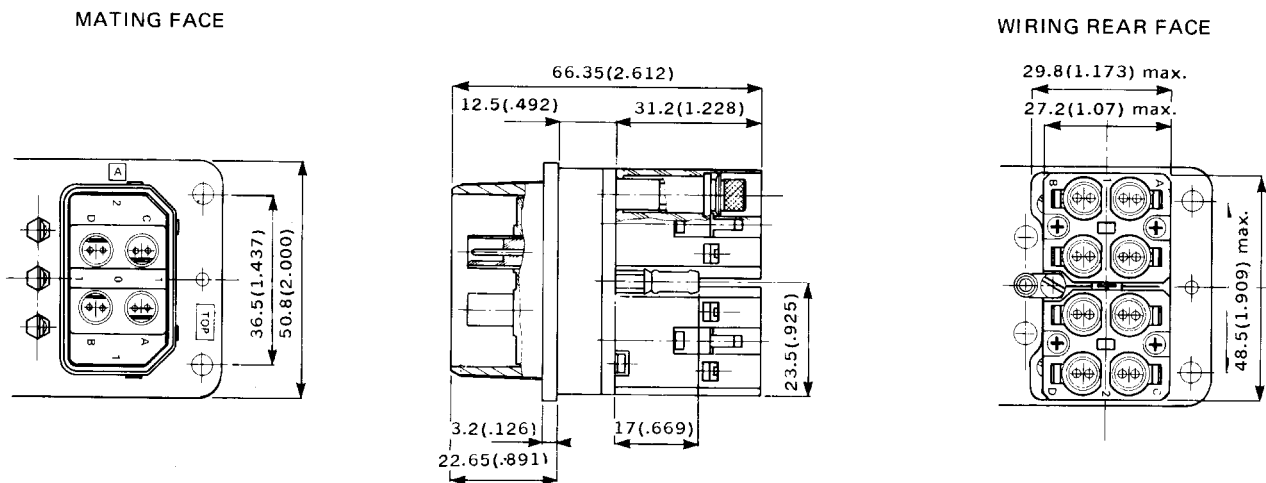

B2TP, H2TP, B4TP & H4TP EQUIPMENT CONNECTOR

The equipment connector comprises one receptacle shell fitted with an insert incorporating 2 (B2S) or 4 (B4S) twinax socket contacts.

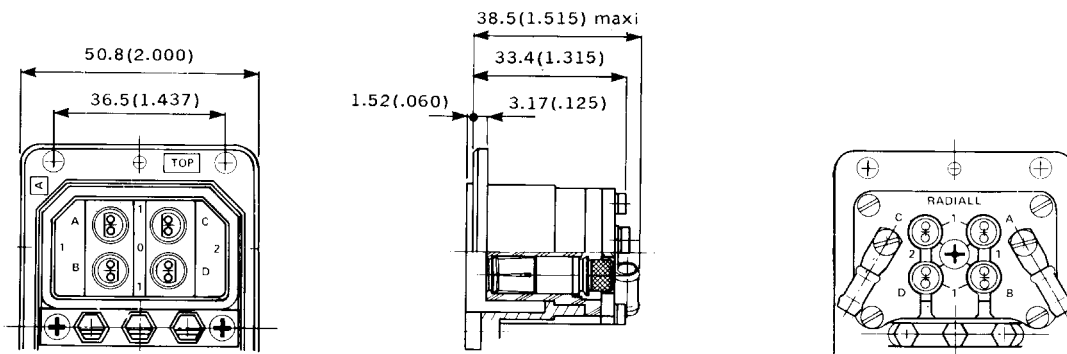

42B2S AIRCRAFT CONNECTOR

The aircraft connector comprises a plug shell fitted with a 42B2S insert.

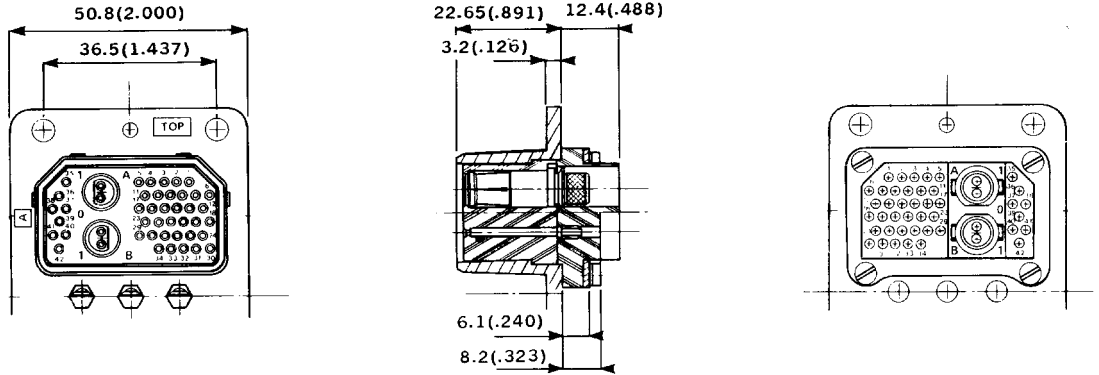

42B2P EQUIPMENT CONNECTOR

The equipment connector comprises a receptacle shell fitted with a 42B2P insert.

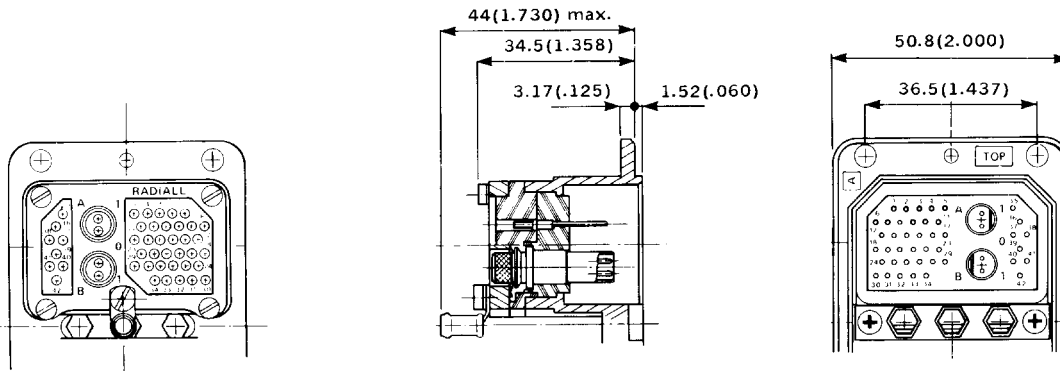

CONTACTS

TWINAX

CONTACT ARRANGEMENT	CABLE	PIN	SOCKET	CENTER CONTACT			OUTER BODY		
				CRIMPING TOOL RADIALL P/N (MIL P/N)	POSITIONER RADIALL P/N (MIL P/N)	SEL.	CRIMPING TOOL RADIALL P/N (MIL P/N)	DIE RADIALL P/N (MIL P/N)	HEX.
B2TP B4TP	F2709/1 2	/	616090	282281 (M22520/2-01)	282959	7	282293 (M22520/5-01)	282248 OCETA M1001	/
H4TP H2TP 42B2S	F2709/9	/	616091			6			/
B4S B2S	AWG 20 AWG22 AWG24	/	616092			7 6 5	NOT APPLICABLE	/	
42B2P	AWG 20 AWG22 AWG24	616192	/			7 6 5		/	

DSX 4 G 12 S 14 S 16 S 25 S 00 01

Series _____

Shell size _____
 1 : one gang shell
 2 : two gang shell
 3 : three gang shell
 4 : four gang shell

Shell type _____
 G : receptacle
 H : plug

Gang A contact arrangement _____
 (see table below and pages 43 and 44)

Termination style _____
 (see notes 2 and 3 for coax contacts)
 X : without contacts
 S : crimp (see note 1)
 Z : fixed solder cup
 K : wire wrap one level
 V : wire wrap two levels
 W : wire wrap three levels
 Y : PC tail contact
 } (see notes 5)

Gang B _____

Gang C _____

Gang D _____

Modification code _____
 (see pages 18 to 20)

Polarization code _____
 (see note 4 and pages 21 to 23)

Contact arrangement code table

	00	8	13	26	40	45	57	67	106	32C2	32C4	40C1	C2	C3	C8	D8
insert for pin contacts	10	12	44	14	16	18	20	22	24	26	40	28	34	36	30	38
insert for socket contacts	11	13	45	15	17	19	21	23	25	27	41	29	35	37	31	39

Notes :

- 1 If you need to use reduced crimp barrel contacts, use code X and order contacts separately.
- 2 For C2, C3 and C8 contact arrangements which include coax contacts, use termination code X and order coax contacts separately.
- 3 For mixed layout 32C2, 32C4 and 40C1, the connector is delivered with signal and power contacts but without coax contacts. Order coaxial contacts separately.
- 4 Without polarization code : the connector is delivered with polarizing system unassembled
 Polarization code 00 : the connector is delivered without polarizing system
 Polarization code from 01 to 216 : the connector is delivered with the polarization hardware assembled as defined by code.
- 5 For contact arrangement 67 and 32C4 with K, V, W or Y termination styles, size 16 contacts are crimp contacts shipped loose with the connector.

MATERIALS

DESCRIPTION	MATERIAL	PLATING
Shell	Aluminum alloy	Cadmium yellow chromate or nickel
Insert	Thermosetting resin	
Metallic insert	Aluminum alloy	Cadmium clear chromate.
Rear spacer	Silicone rubber	
Retention clip	Copper alloy	
Contact	Copper alloy	Gold over nickel underplate.
Insert retention plate	Aluminum alloy	Gold anodized.
Insert retention plate with attaching tabs	Aluminum alloy	Cadmium yellow chromate or nickel
Polarizing posts	Stainless steel	
Polarizing keys	Zinc alloy	Cadmium yellow chromate or nickel
Polarizing keys retention plate	Aluminum alloy	Gold anodized or nickel plated blue painted.
Screws,washers,clinch-nut	Corrosion resistant steel	

ELECTRICAL CHARACTERISTICS

They are the same as those described for MIL-C-81659B connectors (see page 6).

MECHANICAL AND ENVIRONMENTAL

They are the same as those described for MIL-C-81659B connectors (see page 7) except that for ARINC 404 connectors no altitude moisture injection test is performed. This test being replaced by a moisture resistance test performed according to method 1002.2 type II of MIL-STD-1344A.

PIN INSERT MATING SIDE SHOWN

8

Number of contacts	Contact size	Location
8	12	1 to 8

DWV = 1500 V - 60Hz
Available for termination : S - Z

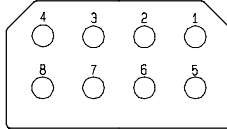

45

Number of contacts	Contact size	Location
45	20	1 to 45

DWV = 1500 V - 60Hz
Available for termination :
S - Z - Y - K - V - W for pin insert
S - Z - W for socket insert

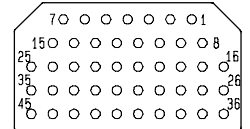

13

Number of contacts	Contact size	Location
13	16	1 to 13

DWV = 1500 V - 60Hz
Available for termination : S
This insert has no separator

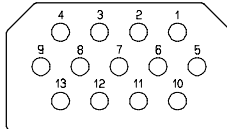

57

Number of contacts	Contact size	Location
57	20	1 to 57

DWV = 1500 V - 60Hz
Available for termination :
S - Z - Y - K - V - W for pin insert
S - Z - W for socket insert

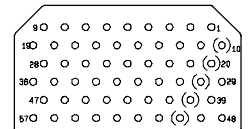

D8

Number of contacts	Contact size	Location
4	16	1 to 4
4	12	5 to 8

DWV = 1500 V - 60Hz
Available for termination : S - Z

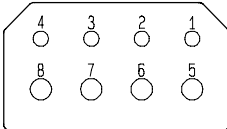

67

Number of contacts	Contact size	Location
64	20HD	1, 2 & 6 to 67
3	16	3, 4 & 5

DWV = 1000 V - 60Hz
Available for termination :
S - Z - Y - K - V - W for pin insert
S - Z - W for socket insert

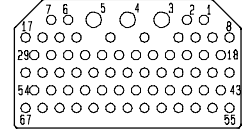

26

Number of contacts	Contact size	Location
26	16	1 to 26

DWV = 1500 V - 60Hz
Available for termination : S - Z

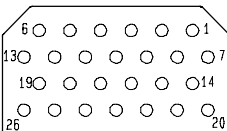

106

Number of contacts	Contact size	Location
106	22	1 to 106

DWV = 1000 V - 60Hz
Available for termination :
S - Y - V - W

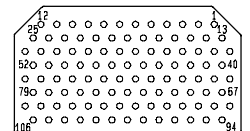

40

Number of contacts	Contact size	Location
40	20	1 to 40

DWV = 1500 V - 60Hz
Available for termination :
S - Z - Y - K - V - W for pin insert
S - Z - W for socket insert

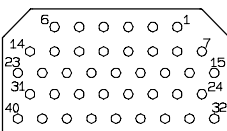

40C1

Number of contacts	Contact size	Location
1	5 (coax)	A1
39	20	1 to 39

DWV = 1500 V - 60Hz
Available for termination :
S - Z - Y - K - V - W for pin insert
S - Z - W for socket insert

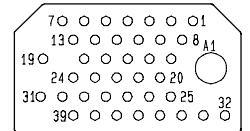

PIN INSERT MATING SIDE SHOWN

32C2

C8

Number of contacts	Contact size	Location
2	5 (coax)	A1 & A2
30	20	1 to 30

DWV = 1500 V - 60Hz
(1000V for coax contact cavity)

Available for termination :

S - Z - Y - K - V - W for pin insert

S - Z - W for socket insert

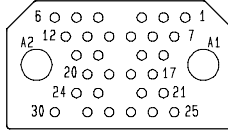

Number of contacts	Contact size	Location
8	9 (coax)	1 to 8

DWV = 1000 V - 60Hz

Available for termination : S

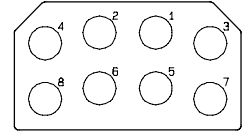

32C4

00

Number of contacts	Contact size	Location
4	9 (coax)	29 to 32
4	16	8, 9 & 23, 24
24	20	1 to 7 & 10 to 22 & 25 to 28

DWV = 1500 V - 60Hz

(1000V for coax contact cavity)

Available for termination :

S - Z - Y - K - V - W for pin insert

S - Z - W for socket insert

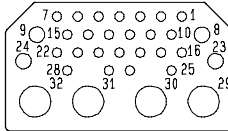

Number of contacts	Contact size	Location
0	/	/



C2

Number of contacts	Contact size	Location
2	1 (coax)	1 & 2

This insert is metallic

Available for termination : S

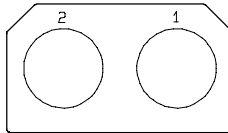

C3

Number of contacts	Contact size	Location
2	7 (coax)	1 to 3
1	3	2

This insert is metallic

Available for termination : S

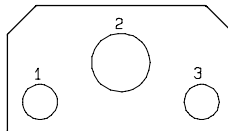

SIGNAL AND POWER CRIMP CONTACTS SIZES 22, 20HD, 16, 12

CONTACT SIZE	WIRE				PIN RADIALL P/N (MIL P/N)	SOCKET RADIALL P/N (MIL P/N)	CRIMPING TOOL RADIALL P/N (MIL P/N)	POSITIONER RADIALL P/N (MIL P/N)	SELECTOR	INS/EXT TOOL RADIALL P/N (MIL P/N)
	AWG	cross section (mm)	wire outside dia. inch (mm)	striping length inch (mm)						
22	22 24 26	0.38 0.21 0.14	.055 (1.4)	.138 (3.5)	616200 (MIL 39029/11-144)	616300 (MIL 39029/12-148)	282281 (MIL 22520/2-01)	282970 (MIL 22520/2-23)	4 3 3	282885 (M81969/1-01)
22 reduced crimp barrel	28 30	0.093 0.055	.055 (1.4)	.138 (3.5)	616201	616301			5 4	
20HD	20 22 24	0.60 0.38 0.21	.071 (1.8)	.157 (4.0)	616210 (MIL 39029/11-145)	616310 (MIL 39029/12-149)	282281 (MIL 22520/2-01)	282971 (MIL 22520/2-08)	7 6 5	282886 (M81969/1-02)
20HD reduced crimp barrel	26 28 30	0.14 0.093 0.055	.071 (1.8)	.157 (4.0)	616211	616311			6 5 4	
20	20 22 24	0.60 0.38 0.21	.071 (1.8)	.157 (4.0)	610220	610325	282291 (MIL 22520/1-01)	282972 (MIL 22520/1-02)	4 3 3	282943
20 reduced crimp barrel	26 28 30	0.14 0.093 0.055	.071 (1.8)	.157 (4.0)	610221	610321			3 3 2	
16	16 18 20	1.34 0.93 0.60	.102 (2.6)	.236 (6.0)	616230 (MIL 39029/11-146)	616330 (MIL 39029/12-150)	282291 (MIL 22520/1-01)	282972 (MIL 22520/1-02)	6 5 4	282546 (M81969/1-03)
16 reduced crimp barrel	20 22 24	0.60 0.38 0.21	.102 (2.6)	.236 (6.0)	616231	616331			5 5 4	
12	12 14 16	3.18 1.91 1.34	.134 (3.4)	.236 (6.0)	616240 (MIL 39029/11-147)	616340 (MIL 39029/12-151)	282291 (MIL 22520/1-01)	282579 (MIL 22520/1-11)	8 7 6	282547 (M81969/28-02)

SIZES 22, 20HD & 20 PC TAIL CONTACTS

PC tail contacts are delivered installed in the connector. Connectors with PC tail contacts have no separator. For 32C4 and 67 contact arrangements, size 16 contacts are delivered in crimp termination and are shipped loose with the connector.

CONTACT SIZE	CONTACT ARRANGEMENT	PIN	SOCKET	EXTRACTION TOOL	DIMENSIONS					
					Y	B	dia	D	E	
22	106	616206*	616379	282890	.240/.209 (6.1/5.3)	.256 (6.5)	.023 (0.6)	.994/1.013 (25.25/25.75)	.061/.069 (1.55/1.75)	
					616303	.567/.535 (14.4/13.6)				.370 (9.4)
					616306*	.232/.263 (5.9/6.7)				.149 (3.8)
20HD	67	610216*	/	282891	.226/.262 (5.75/6.65)	/	.031 (.08)	1.149/1.173 (29.20/29.80)	.212/.228 (5.40/5.80)	
	32C4				.250/.297 (6.35/7.55)			1.169/1.192 (29.70/30.30)		
	67	610219			.131/.168 (3.35/4.25)		.029 (0.75)	1.149/1.173 (29.20/29.80)		
	32C4				.155/.203 (3.95/5.15)			1.169/1.192 (29.70/30.30)		
20	40-45-57 32C2-40C1	610226*	/	282943	.240/.291 (6.10/7.40)	/	.031 (0.8)	1.124/1.147 (28.55/29.15)	.212/.228 (5.40/5.80)	

Connectors delivered in the "Y" termination style will be fitted with contacts marked by "*" (see above table). If you want to use an other kind of pc tail contact, use termination style "x" when ordering the connector and order contacts separately.

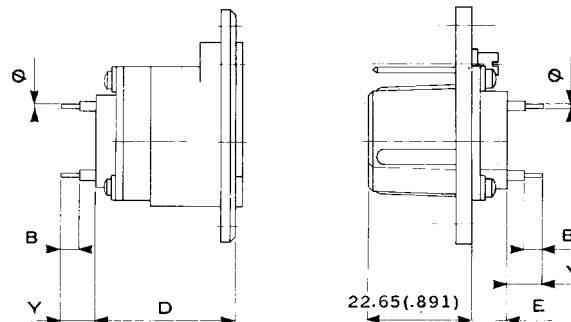

CONTACTS WITH WIRE WRAP POST SIZES 22, 20HD & 20

Wire wrap contacts are delivered installed in the connector. Connectors with wire wrap contacts have no separator. For 32C4 and 67 contact arrangements, size 16 contacts are delivered in crimp termination and are shipped loose with the connector.

CONTACT SIZE	AWG	CONTACT ARRANGEMENT	PIN	SOCKET	INSERTION TOOL	DIMENSIONS				
						D	E	K (1 wrap)	V (2 wrap)	W (3 wrap)
22	26 28 30	106	610203 (2 wrap levels)	610303 (2 wrap levels)	282948	.994/1.013 (25.25/25.75)	.061/.069 (1.55/1.75)		.394/.433 (10/11)	.492/.531 (12.50/13.50)
			610204 (3 wrap levels)	610304 (3 wrap levels)						
20HD	26 28 30	67	610217 (1 wrap level)	610314 (3 wrap levels)	282948	1.133/1.150(2 8.8/29.2)	.212/.228 (5.40/5.80)	.250/.289 (6.35/7.35)	.368/.407 (9.35/10.35)	.466/.506 (11.85/12.85)
		32C4	610215 (2 wrap levels)							
20	26 28 30	40-45-57-32C2-41C 1	610228 (1 wrap level)	610324 (3 wrap levels)	282949	1.147/1.124 (28.55/29.15)	.212/.228 (5.40/5.80)	.273/.325 (6.95/8.25)	.391/.443 (9.95/11.25)	.496/.543 (12.60/13.80)
			610225 (2 wrap levels)							
			610224 (3 wrap levels)							

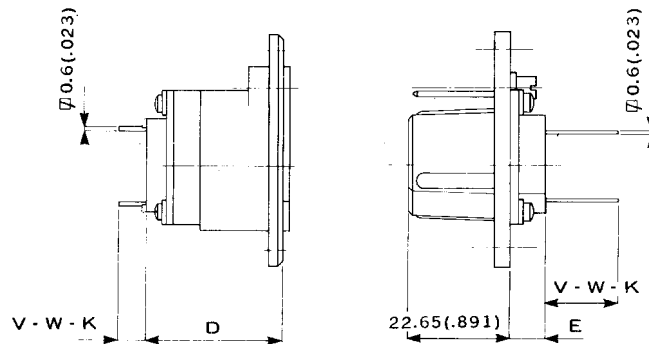

SOLDER CUP CONTACTS SIZES 20HD, 20, 16 & 12

Solder cup contacts are fixed contacts delivered installed in the connector. Connectors with solder cup contacts have no separator.

CONTACT SIZE	CONTACT ARRANGEMENT	STRIPPING LENGTH	DIMENSIONS		
			A	D	E
20HD	67	.098 (2.5)	.118 (3.0)	1.149/1.173 (29.20/29.80)	.212/.228 (5.40/5.80)
	32C4			1.169/1.192 (29.70/30.30)	
20	40-45-57 32C2-40C1	.197 (5.0)	.177 (4.5)	1.124/1.147 (28.55/29.15)	
16	26-67			1.149/1.173 (29.20/29.80)	
		32C4	1.169/1.192 (29.70/30.30)		
12	8-D8			1.124/1.147 (28.55/29.15)	

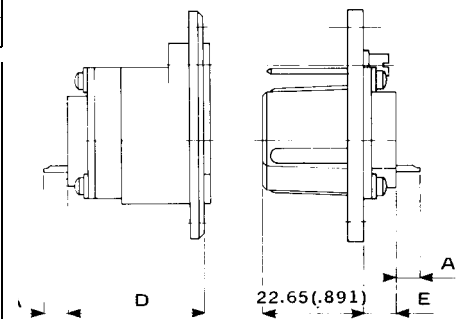

THERMOCOUPLE CONTACTS SIZES 22 & 20HD

See page 11

FIBER OPTIC TERMINI SIZES 16 & 12

See page 12

COAXIAL CRIMP CONTACTS SIZE 1

CONTACT SIZE	CONTACT ARRANGEMENT	CABLE	PIN	SOCKET	CENTER CONTACT			OUTER BODY			WIRING INSTR.		
					CRIMPING TOOL RADIALL P/N (MIL P/N)	POSITIONER RADIALL P/N (MIL P/N)	SEL.	CRIMPING TOOL RADIALL P/N (MIL P/N)	DIE RADIALL P/N (MIL P/N)	HEX.			
1	C2	UT 141 RG 402	616005	/	solder contact						C1 page 58		
		RG 58 RG 141 KX 15	616006 right angle	/	solder contact			282293 (M22520/5-01)	282246 (M22520/5-05)	A	E page 59		
		RG 214 RG 225	/	610108							282247 (M22520/5-61)	A	D page 58
		SMA	616009	/	SMA termination							NA	

For other cables, consult RADIALL

PART NUMBER	616006	616009 - 610108	616005
Dielectric withstanding voltage at sea level (V rms)	1000	1500	2500

COAXIAL CRIMP CONTACTS SIZE 3

CONTACT SIZE	CONTACT ARRANGEMENT	CABLE	PIN	SOCKET	CENTER CONTACT			OUTER BODY			WIRING INSTR.
					CRIMPING TOOL RADIALL P/N (MIL P/N)	POSITIONER RADIALL P/N (MIL P/N)	SEL.	CRIMPING TOOL RADIALL P/N (MIL P/N)	DIE RADIALL P/N (MIL P/N)	HEX.	
3	C3	RG 214 RG 225	/	610118	solder			282293 (M22520/5-01)	282247 (M22520/5-61)	A	D page 58
		UT 141 RG 402	616014	/	solder						C3 page 58

For other cables, consult RADIALL

Dielectric withstanding voltage at sea level : 1500 V rms.

COAXIAL CRIMP CONTACTS SIZE 5

CONTACT SIZE	CONTACT ARRANGEMENT	CABLE	PIN	SOCKET	CENTER CONTACT			OUTER BODY			WIRING INSTR.	
					CRIMPING TOOL RADIALL P/N (MIL P/N)	POSITIONER RADIALL P/N (MIL P/N)	SEL.	CRIMPING TOOL RADIALL P/N (MIL P/N)	DIE RADIALL P/N (MIL P/N)	HEX.		
5	32C2 40C1	RG 58 RG141 KX 15	610120	610020001	solder			282293 (M22520/5-01)	282246 (M22520/5-05)	A	A3 page 56	
		RG 142 RG 223 KX 23	610122	610022001							B	B3 page 57
		RG 316 KX 22	610126	610026								B4 page 57
		KX 21 DT	610132	/						B5 page 57		
		RG 178	610127	/						C4 page 58		
		UT 085	610119	/						C2 page 58		
		UT 141	610123	/								

For other cables, consult RADIALL

Extraction tool : 282946 (M81969/28-01)

COAXIAL CRIMP CONTACTS SIZE 7

CONTACT SIZE	CONTACT ARRANGEMENT	CABLE	PIN	SOCKET	CENTER CONTACT			OUTER BODY			WIRING INSTR.
					CRIMPING TOOL RADIALL P/N (MIL P/N)	POSITIONER RADIALL P/N (MIL P/N)	SEL.	CRIMPING TOOL RADIALL P/N (MIL P/N)	DIE RADIALL P/N (MIL P/N)	HEX.	
7	C3	RG 58 RG 141 KX 15	610120	610020001	solder			282293 (M22520/5-01)	282246 (M22520/5-05)	A	A3 page 56
		RG 174 RG 316 RG 188	610126	610026							B3 page 57

For other cables, consult RADIALL
Extraction tool : 282946 (M81969/28-01)
Dielectric withstanding voltage at sea level : 750 V rms.

COAXIAL CRIMP CONTACTS SIZE 9

CONTACT SIZE	CONTACT ARRANGEMENT	CABLE	PIN	SOCKET	CENTER CONTACT			OUTER BODY			WIRING INSTR.
					CRIMPING TOOL RADIALL P/N (MIL P/N)	POSITIONER RADIALL P/N (MIL P/N)	SEL.	CRIMPING TOOL RADIALL P/N (MIL P/N)	DIE RADIALL P/N (MIL P/N)	HEX.	
9	C8 32C4	RG 316 KX 22	610146	610046	solder			282293 (M22520/5-01)	282246 (M22520/5-05)	B	B2 page 57
		RG 178 KX 21	610147	610047						A	A3 page 56
		RG 58 RG 141 KX 15	610140	610040							
		RG 142	610149	610049							
		S280W 503-2	/	610044						282281 (M22520/2-01)	DANIELS K345
		UT 085	610148	/	solder						C5 page 58

For other cables, consult RADIALL
Extraction tool : 282946 (M81969/28-01)

ACCESSORIES

FILLER PLUGS

DESIGNATION	FILLER PLUGS P/N
size 22 (black)	620920
size 20HD (red)	610941
size 16 (blue)	620922
size 12 (yellow)	616923
size 5 (white)	616917
size 9 (white)	616915

DUST CAPS

See page 24

JUNCTION SHELLS

See page 25

SHELL SIZE 1

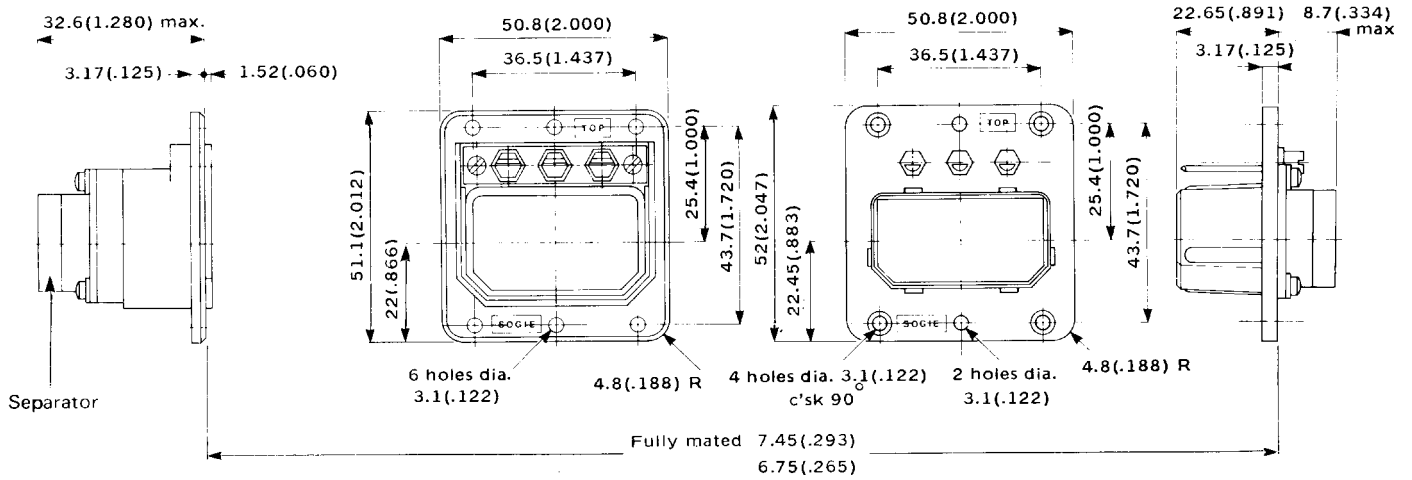

SHELL SIZE 2

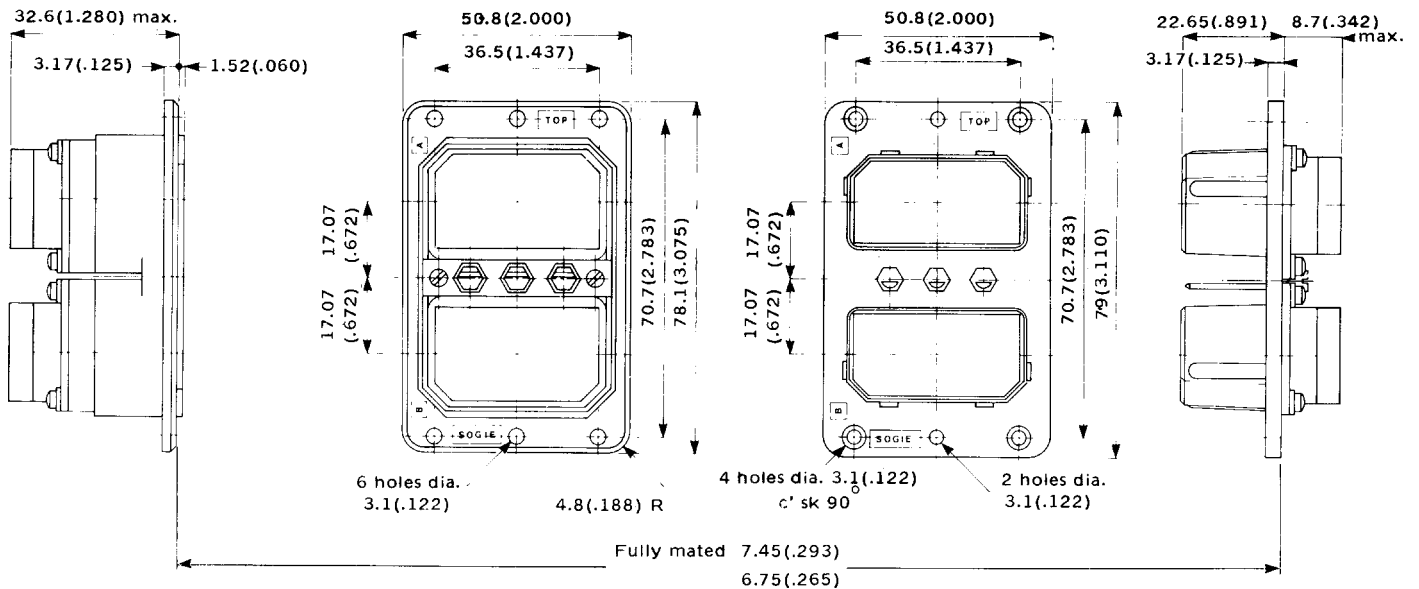

SHELL SIZE 3

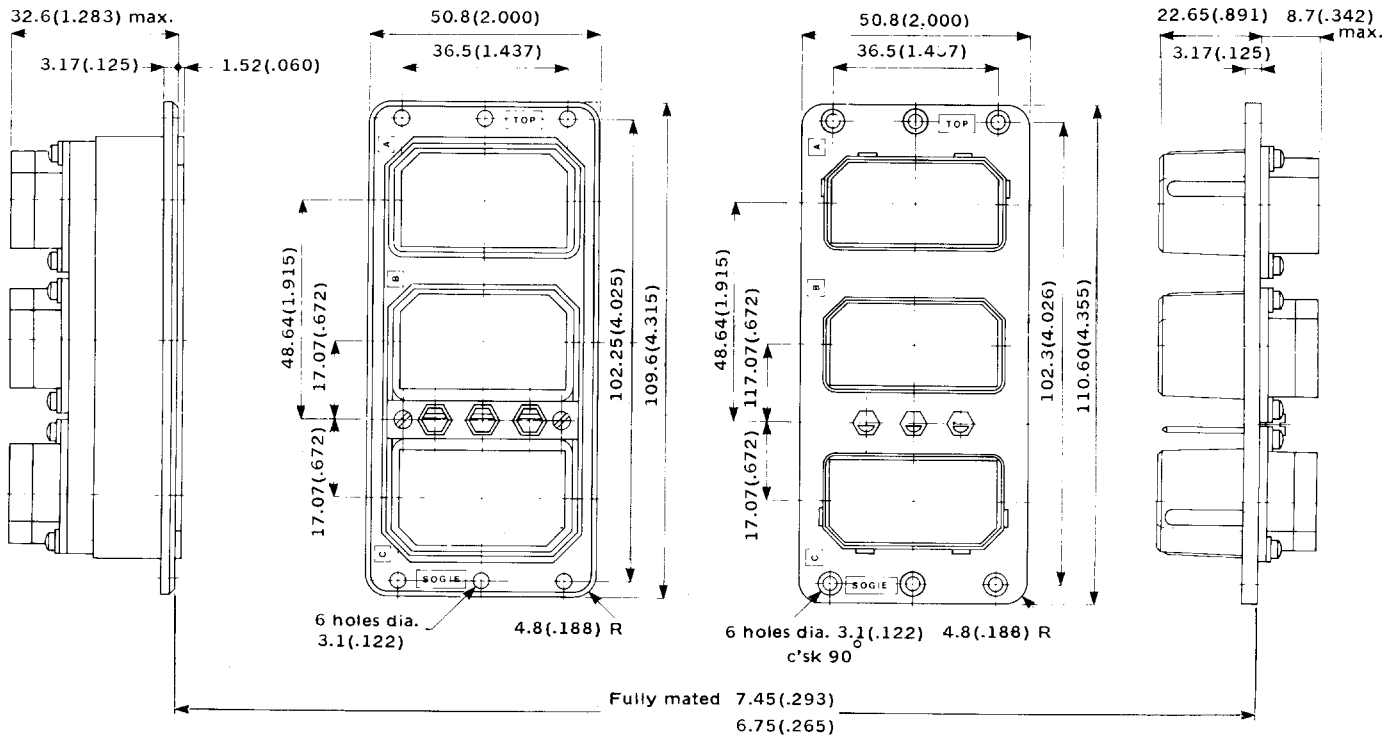

SHELL SIZE 4

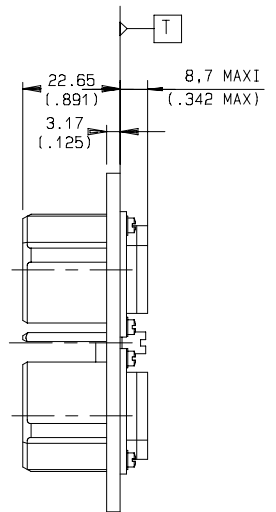
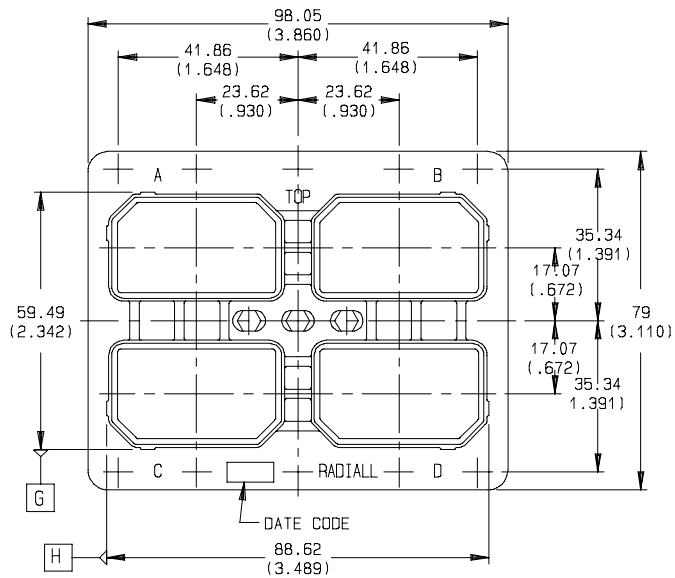
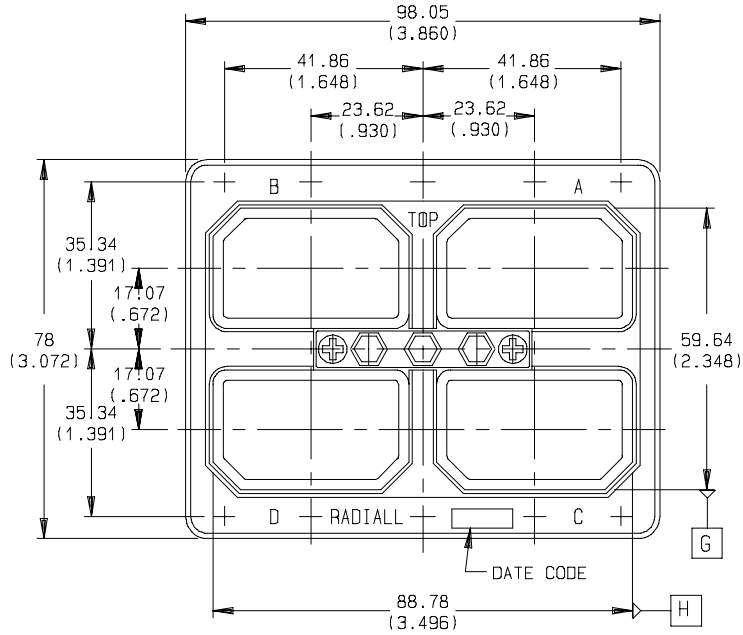
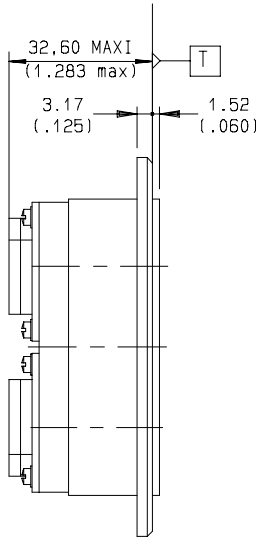

EMI / RFI acts directly on electronics systems whether by conduction mode through the input or output cables or by radiation (coupling).

Electronics equipments are particularly vulnerable to interferences and can be disturbed or damaged by them. The serious consequences which may result, make it essential to protect such installations.

The first stage in protection is to install the equipment in a shielded cabinet which protects it from some of the interferences ; particularly those occurring by radiation. At the connector level that means to use metallic shells so as to have a good mass conduction between the equipment box and the rack.

So as to meet these requirements RADIALL offers plug connectors for rack which are fitted with grounding spring fingers.

Interferences acting by conduction mode through the cables can be attenuated by using RADIALL / JERRIK filtered connectors (see our filtered connectors catalogue).

DSX MIL-C-81659B and DSX ARINC 404 shell type B in shell sizes 1, 2, 3 and 4 fitted with grounding spring fingers are available. These connectors are interchangeable and intermatable with the standard ones.

PART NUMBERING

The part numbering system applies to plug shells only.

To establish the part number of a DSX EMI / RFI connector, simply add the letter "G" after the letter which defines the shell type in the DSX MIL-C-81659B or ARINC 404 shell type B standard part number.

Examples of part numbering :

DSX N 2 P G S40S S45S 00 01
DSX 2 H G 41S 19S 00 01.

TECHNICAL CHARACTERISTICS

The technical characteristics are the same as those of MIL-C-81659B and ARINC 404 shell type B connectors except for the following.

DESCRIPTION	MATERIAL	PLATING
Grounding spring fingers	copper alloy	Tin lead alloy over nickel

Shell to shell conductivity : 2.5 mΩ max. Measured according to method 3007 of MIL-STD-1344A.
Shielding effectiveness : > 70 dB at 1 GHz. Measured according to method 3008 of MIL-STD-1344A.

DSX 1 F 18 S 00

Series _____

Shell size _____
1 : one gang shell

Shell type _____
E : receptacle
F : plug

Contact arrangement _____
(see table below and pages 43 to 44)

Termination style _____
(see notes 2 and 3 for coax contacts)
X : without contacts
S : crimp (see note 1)
Z : fixed solder cup
K : wire wrap one level
V : wire wrap two levels
W : wire wrap three levels
Y : PC tail contact
} (see notes 4)

Modification code _____
(see pages 18 to 20)

Contact arrangement code table

	00	8	13	26	40	45	57	67	106	32C2	32C4	40C1	C2	C3	C8	D8
insert for pin contacts	10	12	44	14	16	18	20	22	24	26	40	28	34	36	30	38
insert for socket contacts	11	13	45	15	17	19	21	23	25	27	41	29	35	37	31	39

Notes :

- 1 If you need to use reduced crimp barrel contacts , use code X and order contacts separately.
- 2 For C2,C3 and C8 contact arrangements, use termination code X and order coax contacts separately.
- 3 For mixed layout 32C2, 32C4 and 40C1, connectors are delivered with signal and power contacts but without coax contacts.
Order coaxial contacts separately
- 4 For contact arrangement 67 and 32C4 with K, V, W or Y termination styles, size 16 contacts are crimp contacts shipped loose with the connector.

MATERIALS

DESCRIPTION	MATERIAL	PLATING
Shell	Aluminum alloy	Cadmium yellow chromate
Insert	Thermosetting resin	
Metallic insert	Aluminum alloy	Cadmium clear chromate.
Rear spacer	Silicone rubber	
Retention clip	Copper alloy	
Contact	Copper alloy	Gold over nickel underplate.
Insert retention plate	Aluminum alloy	Gold anodized.
Screws,washers,clinch-nut	Corrosion resistant steel	

ELECTRICAL CHARACTERISTICS

see page 6

MECHANICAL AND ENVIRONMENTAL

see page 7

MODIFICATION CODE

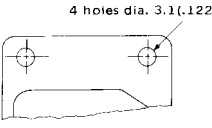
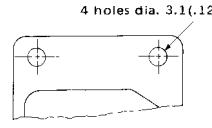
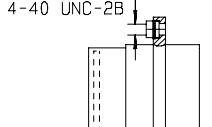
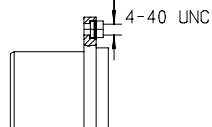
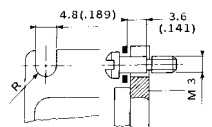
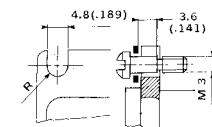
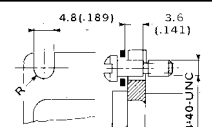
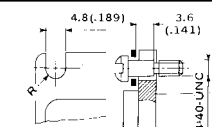
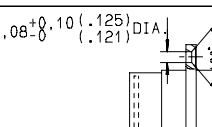
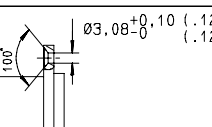
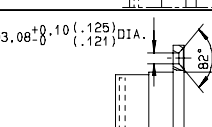
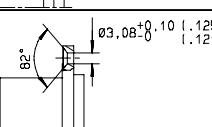
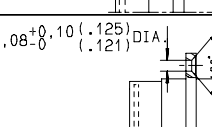
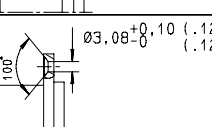
CODE	RECEPTACLE SHELL	PLUG SHELL
00	 <p>4 holes dia. 3.1 (.122)</p>	 <p>4 holes dia. 3.1 (.122)</p>
01	 <p>4-40 UNC-2B</p>	 <p>4-40 UNC-2B</p>
03	 <p>4.8 (.189) 3.6 (.141) M3</p>	 <p>4.8 (.189) 3.6 (.141) M3</p>
04	 <p>4.8 (.189) 3.6 (.141) 4-40 UNC</p>	 <p>4.8 (.189) 3.6 (.141) 4-40 UNC</p>
05	 <p>$\varnothing 3.08^{+0.10}_{-0} (.125) (.121)$ DIA. 100°</p>	 <p>$\varnothing 3.08^{+0.10}_{-0} (.125) (.121)$ DIA. 100°</p>
06	 <p>$\varnothing 3.08^{+0.10}_{-0} (.125) (.121)$ DIA. 82°</p>	 <p>$\varnothing 3.08^{+0.10}_{-0} (.125) (.121)$ DIA. 82°</p>
07	 <p>$\varnothing 3.08^{+0.10}_{-0} (.125) (.121)$ DIA. 100°</p>	 <p>$\varnothing 3.08^{+0.10}_{-0} (.125) (.121)$ DIA. 100°</p>

CONTACT ARRANGEMENTS

They are the same as those used on ARINC 404 shell type B connectors (see pages 43 and 44).

CONTACTS

The contacts used are those shown on pages 45 to 48.

ACCESSORIES

See page 48.

DSX ARINC 404 shell type A size 1 connectors cannot be fitted with any backshell.

DIMENSIONS

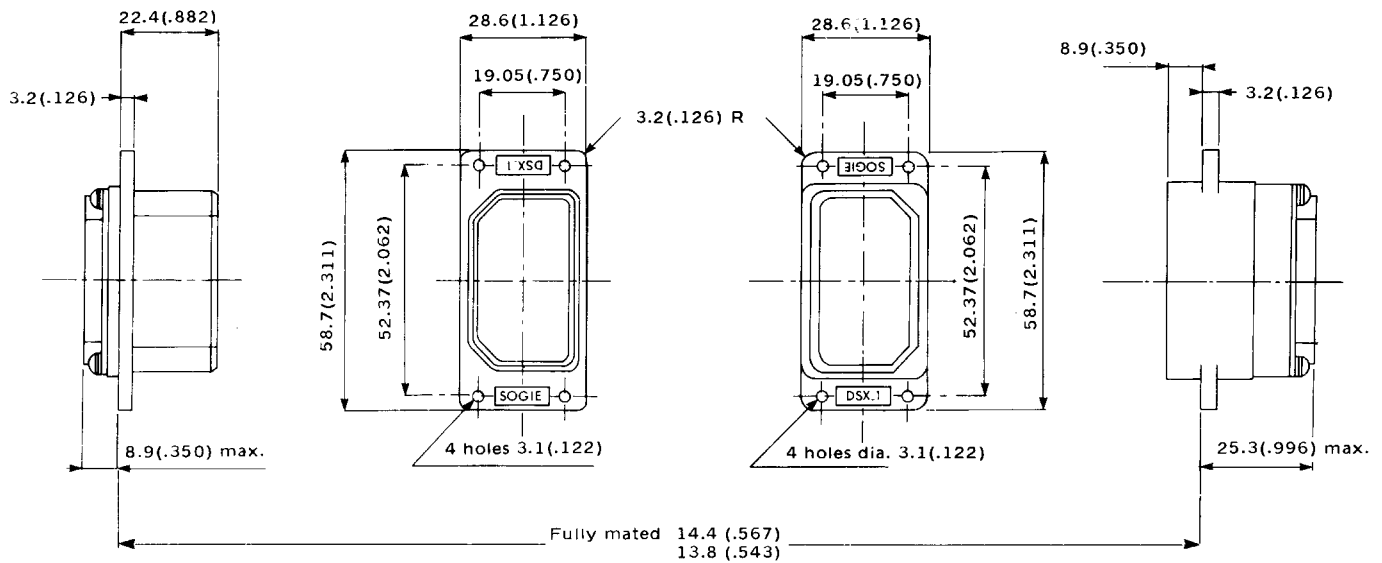

PANEL CUT-OUT

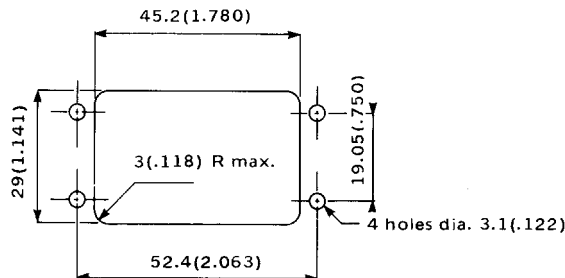

CODE A

1 - Slide ferrule on cable and strip cable to dimensions X, Y, Z shown in table

2 Insert conductor in centre contact.
Crimp or solder contacts as follows :

A1 - A2 - A6

- For 616102001, 616103001, 616111,616112, and 616003 crimp by using crimping tool 282291 and positioner 282997 selector = 8.

- For 616107001, 616113 crimp by using crimping tool 282291 and positioner 282997 selector = 7.

- For 616013 solder center contact.

A3 - A4

- For 616020, 616040, 616120, 616140 crimp by using crimping tool 282281 and positioner 282974

- selector = 6 for RG58 and KX15 cable.
- selector = 8 for RG141 cable.

- For 616021, 616041, 616121, 616141 crimp by using crimping tool 282281 and positioner 282974

- selector = 8.

- For 616024, 616044, 616124, 616144 crimp contact by using crimping tool 282281 and positioner 282974

- selector = 6.

- For 616030 crimp by using crimping tool 282281 and positioner 282550

- selector = 6 for RG58 and KX15 cable
- selector = 8 for RG141 cable.

- For 616031 crimp by using crimping tool 282281 and positioner 282550

- selector = 8

A5

Crimp contacts by using crimping tool 282281 and positioner 282555
- selector = 2.

3 - After slightly flaring the braid, push the assembly fully into the body.
- Fold back braid on knurled barrel and slide ferrule onto the braid then crimp as follows :

A1 - A2 - A6

- 616013, 616107001, 616113 crimp by using 282293 crimping tool and 282246 hex A dies.

- 616003, 616102001, 616103001, 616111, 616112 crimp by using crimping tool 282293 and 282247 hex A dies.

A3 - A4

- Crimp by using 282293 crimping tool and 282246 hex A dies.

A5

- Crimp by using 282292 crimping tool and positioner 282556.

CODE	X	Y	Z
A1	.354 (9)	.492 (12.5)	.216 (5.5)
A2	.216 (5.5)	.413 (10.5)	.216 (5.5)
A3	.256 (6.5)	.433 (11)	.138 (3.5)
A4	.236 (6)	.354 (9)	.157 (4)
A5	.150 (3.8)	.228 (8.8)	.122 (3.1)
A6	.295 (7.5)	.472 (12)	.236 (6)

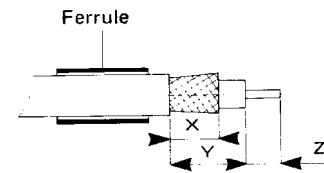

1

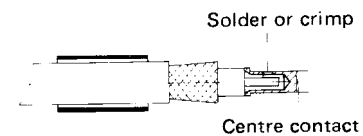

2

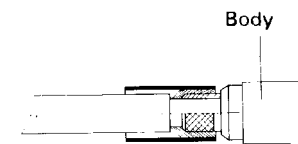

3

CODE B

- 1 - Strip braid over .394 (10).
 - Slide the ferrule over the braid until it butts against the cable jacket then fold the braid back over the ferrule.
 - Strip dielectric to dimension shown, slide the rear insulator on the dielectric until it stops against the braid and the centre conductor into the centre contact.

B1

- For 616022, 616042, 616122, 616142, 616163 contacts by using crimping tool 282281 and positioner 282974
 - selector = 7.
- For 616023, 616043, 616123, 616126, 616127, 616143 contacts crimp by using crimping tool 282281 and positioner 282974
 - selector = 6.
- For 616032, 616022002 contacts crimp by using crimping tool 282281 and positioner 282550
 - selector = 7.

- 2 - Insert conductor in centre contact and solder

- 3 - Push the assembly fully into the body, then crimp by using 282293 crimping tool and 282246 hex B dies.

CODE	X	Y	Z
B1	.394 (10)	.177 (4.5)	.102 (2.6)
B2	.394 (10)	.177 (4.5)	.185 (4.7)
B3	.354 (9)	.118 (3)	.196 (5)
B4	.394 (10)	.138 (3.5)	.102 (2.6)
B5	.413 (10.5)	.138 (3.5)	.185 (4.7)

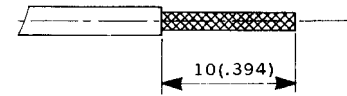

1

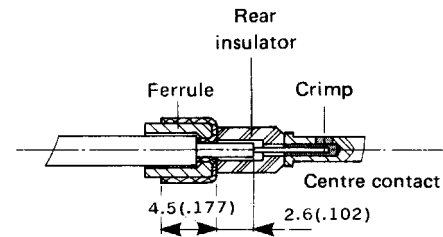

2

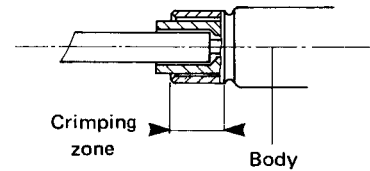

3

CODE C1 - C2 - C3 - C4

- 1 - Strip cable according to dimension X, Y of table.
- Clean the cable to dimension Z.

- 2 - Insert the centre conductor in the centre contact and solder the centre contact respecting the clearance between the dielectric and the shoulder of the centre contact.

- 3 - Insert the centre contact sub-assembly into the contact body and solder.

CODE	X	Y	Z
C1	.098 (2.5)	.177 (4.5)	.126 (3.2)
C2	.078 (2)	.157 (4)	.157 (4)
C3	.055 (1.4)	.216 (5.5)	.157 (4)
C4	.040 (1)	.118 (3)	.188 (4.8)

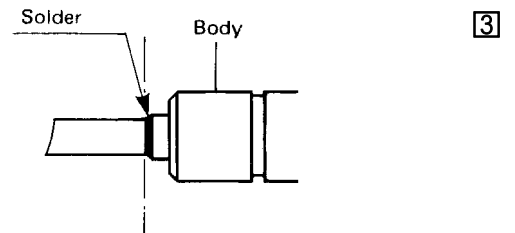
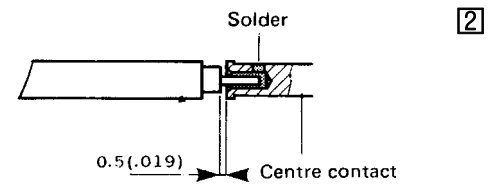
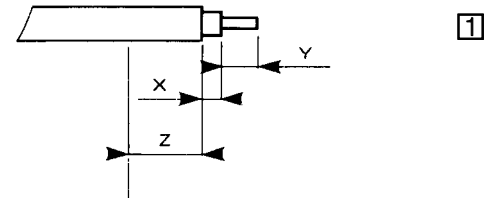

CODE D

- 1 - Slide the clamp nut then the ferrule on the cable then strip the cable to dimensions shown.

- 2 - After slightly flaring the braid, insert the conductor through the barrel in the centre contact.
- Solder the centre contact.
- Fold back the braid over the barrel knurled section and slide the ferrule over the braid.
- Crimp with 282293 crimping tool and 282247 hex A dies.
- Insert this sub assembly in the contact body and screw to 10 - 15 in.lbs torque (1.1 to 1.7 mN)

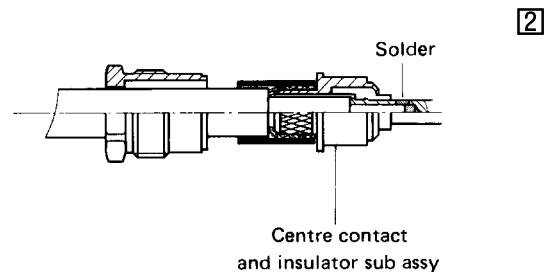
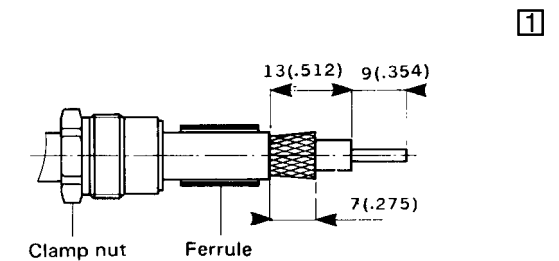

CODE E

1 - Slide the ferrule on the cable then strip the cable to dimensions shown.

- 2** - After slightly flaring the braid, insert the conductor through the barrel in the centre contact groove.
- Solder the centre contact.
 - Fold back the braid over the barrel knurled section and slide the ferrule over the braid. Crimp with 282293 crimping tool and 282246 hex A dies.
 - Solder the cover on the contact body.

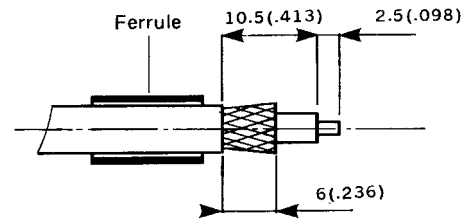

1

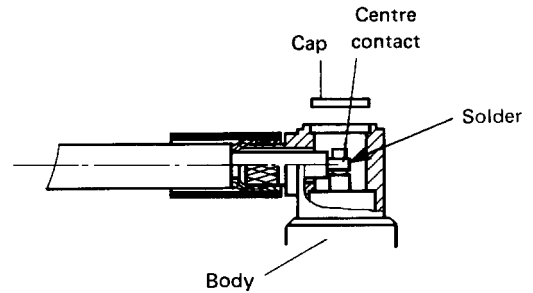

2

CODE F

1 - Slide the ferrule on the cable then strip the cable to dimensions shown.

- 2** - After slightly flaring the braid, slide the sleeve then the rear insulator over the dielectric.
- Insert the conductor in the centre contact.
 - Solder the centre contact.

- 3** - Insert the sub assembly into the contact body then fold back the braid over the barrel knurled section and slide the ferrule over the braid.
- Crimp with 282293 crimping tool and 282247 hex A dies.

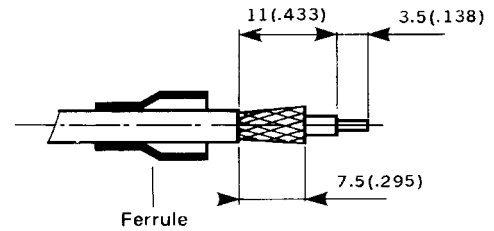

1

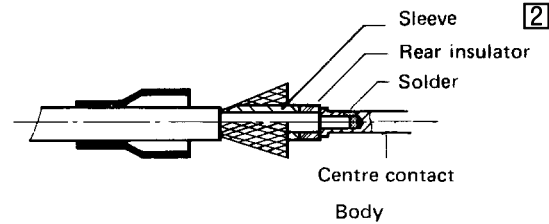

2

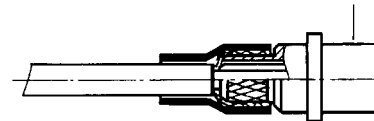

3

CODE G

- 1 - Strip the cable to dimensions shown.
- 2 - Insert the centre conductor in the centre contact.
 - Crimp the centre contact by using crimping tool 282281 and 282555
 - selector = 2.
- 3 - Slide the ferrule onto the braid until it buti against the câble jacket.
 - After slightly flaring the braid, insert centre contact sub-assembly fully into the body.
 - Fold back the braid onto the crimp barrel and slide the ferrule over the braid.
 - Crimp by using crimping tool 282292 and positioner 282556.

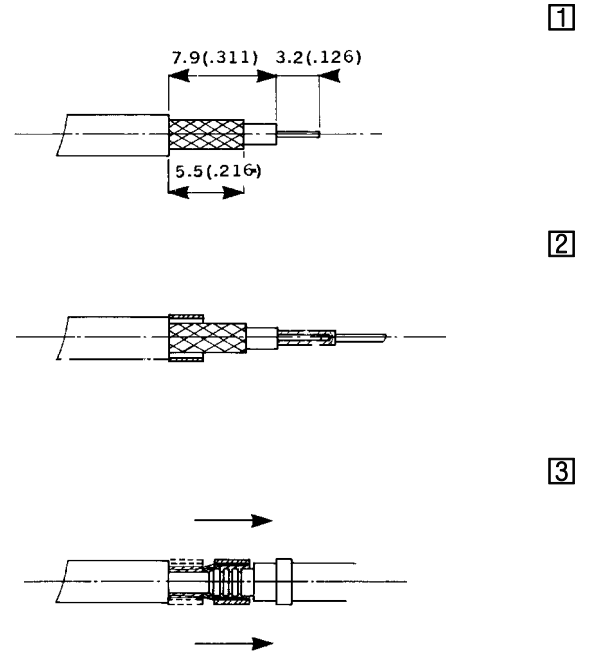

CODE H

- 1 - Slide the ferrule on the cable then strip the cable to dimensions shown.
- 2 - Flare and comb the braid, slide the sleeve over the dielectric.
 - Insert the conductor in the centre contact.
 - Crimp the centre contact by using crimping tool 282281 and positioner 282555
 - selector = 2.
- 3 - Insert the sub-assembly into the contact body then fold back the braid over the barrel and slide the ferrule over the braid (respect the clearance between the ferrule and the body shoulder).
 - Crimp with 282292 crimping tool and positioner 282556.

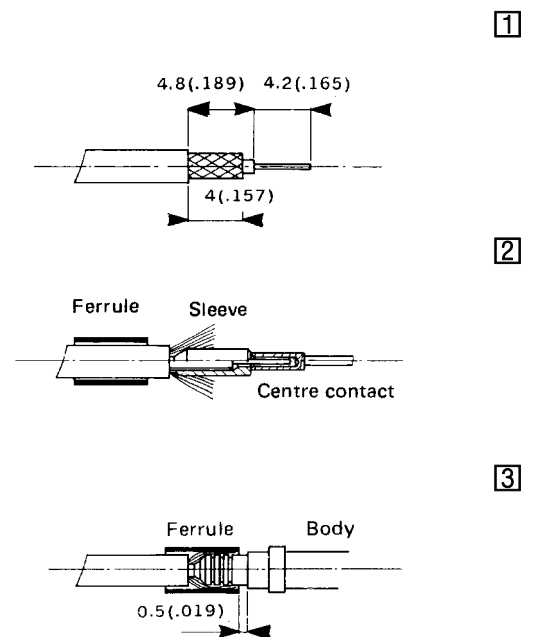

CODE J

- 1** - For environmental application, before stripping, slide sealing boot over cable.
 - For non environmental pin contact (670150, 670151, 618160 and 618161), slide centering boot over cable before stripping

- 2** Trim cable jacket to length indicated.
 - Slide the ferrule over the cable.
 - Cut the high immunity ribbon if any fold back braid or braids over the ferrule as indicated.
 - Cut braid or braids as shown.
 - Cut rod fillers.
 - Strip the two inner conductors.

- 3** - Introduce the N°2 conductor into the intermediate contact crimp pot.
 - Crimp the intermediate crimp pot with crimping tool M22520/2-01 (RADIALL 282281) and positioner RADIALL 282574.
 - selector : 5

- 4** - Put the N°1 cable in the slot of the intermediate contact crimp pot.
 - Slide the center contact over the conductor.
 - Crimp the center contact with crimping tool M22520/2-01 (RADIALL 282281) and positioner RADIALL 282576.
 - selector : 5

- 5** - Install the rear insulator.
 - Introduce this cable assembly into the contact body sub-assembly.

- 6** - Crimp the outer contact body barrel in the indicated crimping area with crimping tool M22520/5-01 (RADIALL 282293) and die M22520/5-45 (RADIALL 282236) hexagonal die closure B (.216 on flats).
 - During the crimping operation push on the cable.

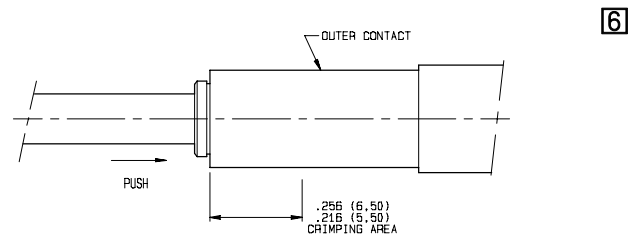
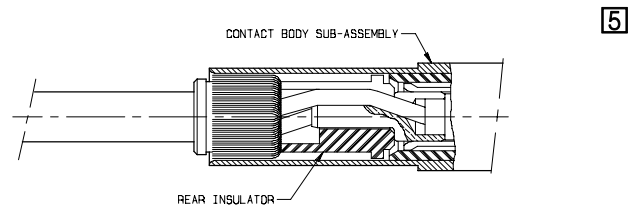
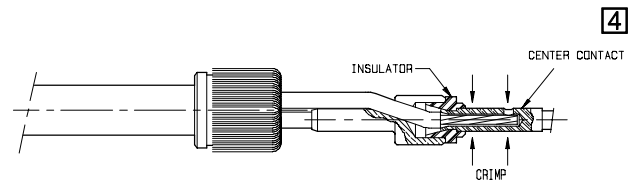
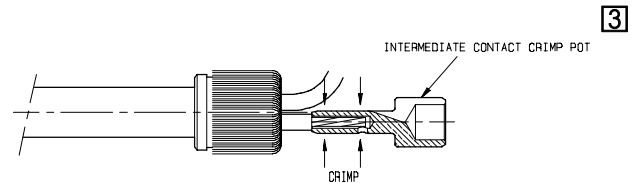
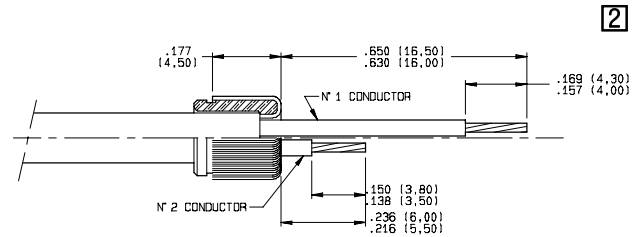
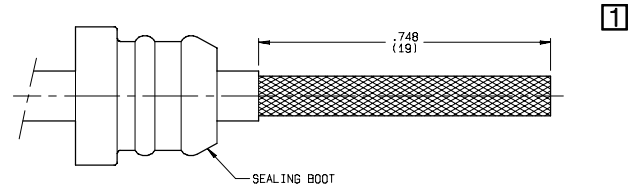

CODE K

- 1 - For environmental application, before stripping, slide sealing boot over cable.
- Trim cable jacket at dimensions shown
- 2 - Slide outer ferrule over the cable.
- Comb and fold the braid back over the ferrule.
- Cut braid at dimension shown.
- 3 - Slide insulator over the cable.
- Strip second braid at dimension shown.
- 4 - Slide intermediate ferrule over the cable.
- Comb and fold the braid back over the ferrule.
- Cut braid at dimension shown.
- Cut dielectric and center conductor at dimension shown.
- 5 - Strip center conductor at dimension shown.
- 6 - Place center contact sub assembly over center conductor and crimp with crimping tool M22520/2-01 (RADIALL 282281) and positioner RADIALL 282576.
- selector : 5
- 7 - Introduce this sub-assembly intermediate contact and crimp with crimping tool M22520/5-01 (RADIALL 282293) and die M22520/5-05 (RADIALL 282246) hexagonal die closure B (.178 on flats).
- During the crimping operation push on the cable.
- 8 - Introduce this sub-assembly into outer contact and crimp with crimping tool M22520/5-01 (RADIALL 282293) and die M22520/5-05 (RADIALL 282246) hexagonal die closure A (.213 on flats).
- During the crimping operation push on the cable.

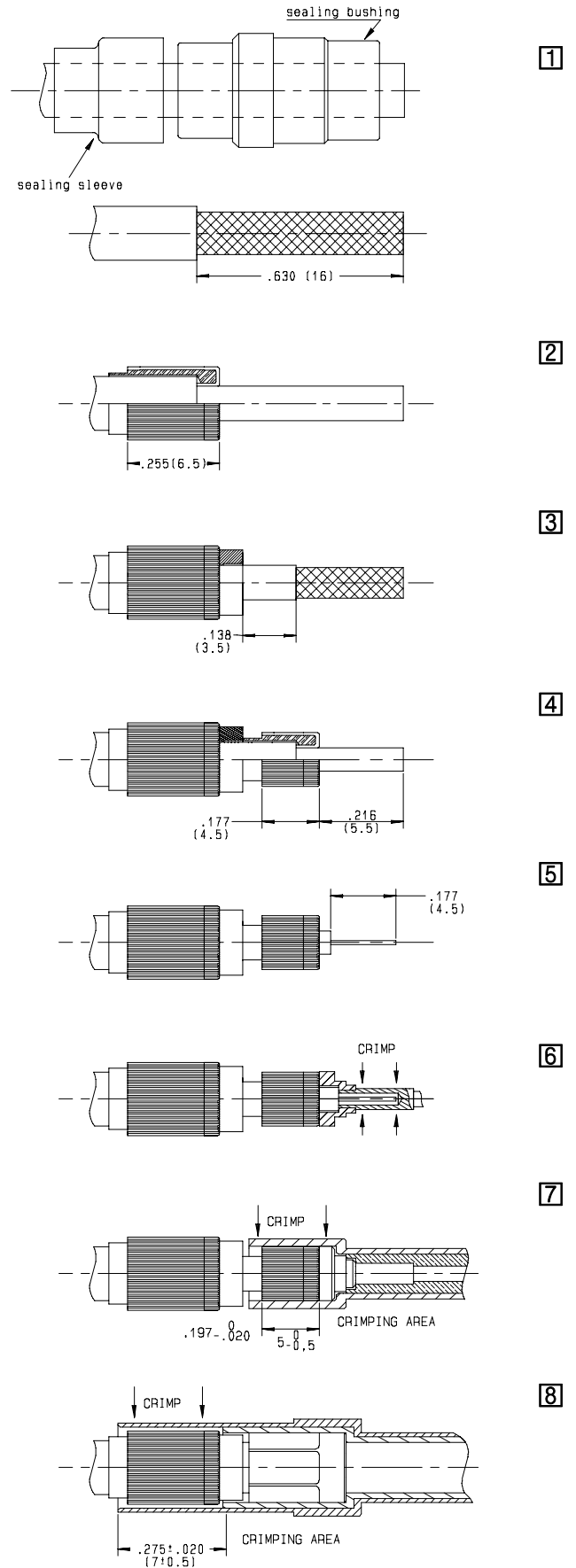

CODE L

- 1 -- Trim jacket, shield and interlayer to dimensions shown.
 - Be careful not to nick outer conductor.

- 2 - Slide ferrule over cable jacket.
 - Push braid clamp over interlayer, outer conductor and under shield until braid clamps bottoms.
 - Slide ferrule forward until it bottoms against shoulder of braid clamp.

- 3 - Comb and fold the braid over the braid clamp.
 - Trim excess braid flush to teflon insulator.
 - Strip inner conductor.
 - Slide center contact sub-assembly over inner conductor bottoming against cable core and braid.
 - Crimp center contact using crimping tool M22520/2-01 (RADIALL 282281) and positioner RADIALL 282576.
 - selector : 5

- 4 - Slide intermediate contact over center contact sub-assembly.
 - Crimp intermediate contact using crimping tool M22520/5-01 (RADIALL 282293) and die M22520/5-01 (RADIALL 282293) hexagonal die closure B (.178 on flats)

- 5 - Introduce this sub-assembly into outer contact until bottoms rear of outer contact should be flush to rear of ferrule.
 - Crimp outer contact using crimping tool M22520/5-01 (RADIALL 282293) and die DANIELS Y 173 hexagonal die closure A (.231 on flats)

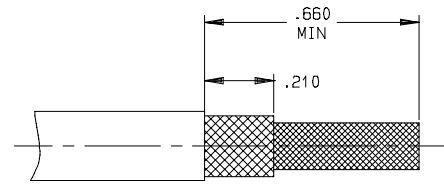

1

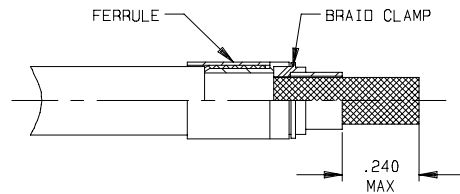

2

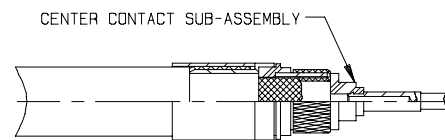

3

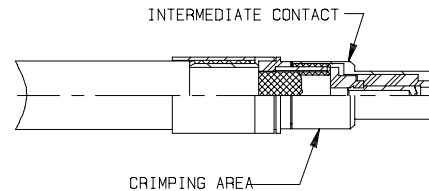

4

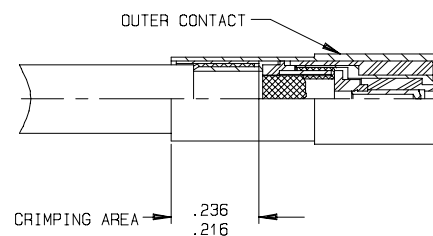

5

CODE M

1 - Strip the cable as shown.

2 - Slide ferrule over sheath.
 - Flare the braid.
 - Insert center conductor to centre contact.
 - Crimp centre contact using crimping tool M22520/2-01 (RADIALL 282281) and positioner DANIELS K370 (RADIALL 282555)
 - selector = 2.

3 - Push cable assembly into body contact.
 - Fold braid over barrel
 - Slide ferrule to .050 of shoulder barrel
 - Crimp the ferrule, turn the contact of about 45° and crimp the ferrule a second time using crimping tool M22520/4-01 (RADIALL 282292) and positioner RADIALL 282556. Removable tool RADIALL 282892.

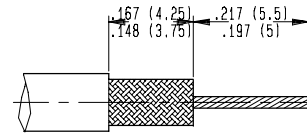

1

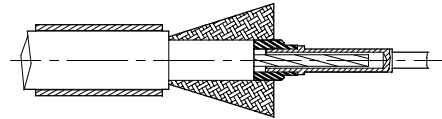

2

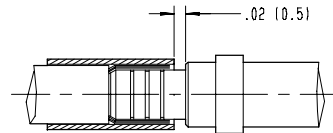

3

CODE N

1 - Strip the braid over .886 (22.5)

2 - Slide the ferrule over the braid until it butts against the cable outer jacket then fold back braid over the ferrule and cut to dimension shown.
 - Strip the dielectric to the dimension indicated on the drawing and fold the centre conductor as shown.

3 - Slide the pillar, the washer and the centre contact over the centre conductor and solder.
 - Slide fully the centre contact sub-assembly into the contact outer body and crimp by with 282293 crimping tool and 282246 hex B dies.

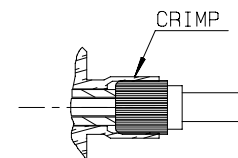
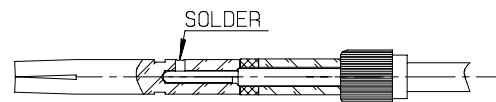
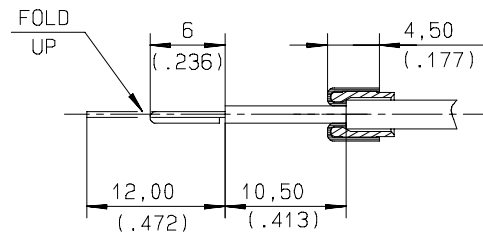
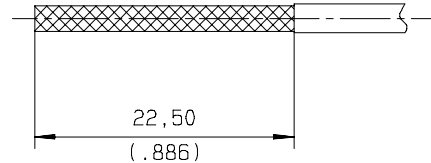

CODE P

1 - Trim cable to dimensions shown.

2 - Slide ferrule on braid until it butts against outer jacket.
Comb braid until all strands are straight fold back braid over ferrule.

3 - Insert cable sub-assy into outer contact until it butts.
Crimp barrel with crimping tool M22520/5-01 and die M22520/5-05 Hex B.

4 - Solder center conductor in center slot.
Solder cap onto outer contact.

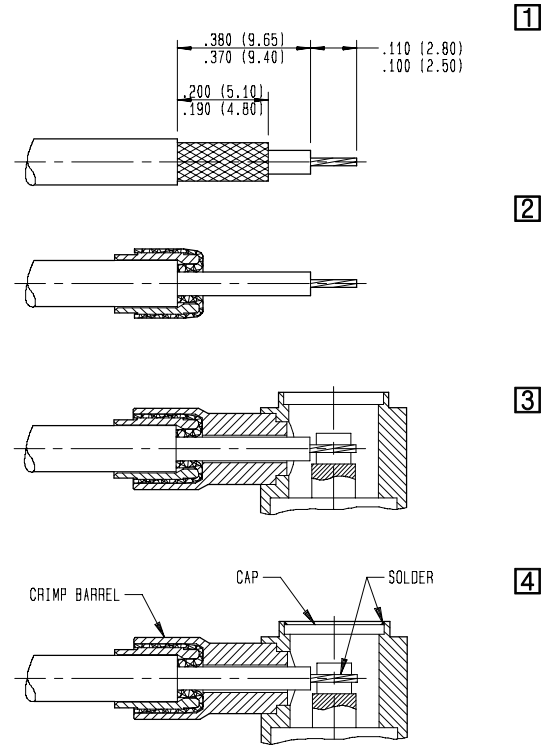

CODE R

1 - Strip braid over .433 (11).

2 - Slide the ferrule over the braid until it butts against the cable jacket then fold the braid back over the ferrule.
- Strip dielectric to dimension shown.

3 - Slide this sub-assembly into the outer body.
- Solder or crimp the braid with 282293 crimping tool and 282246 Hex B dies.
- Solder centre conductor onto the centre contact and caulk the cap on a minimum of three points.

4 - Crimp ferrule by using crimping tool 282293 and dies 282246 hex B.

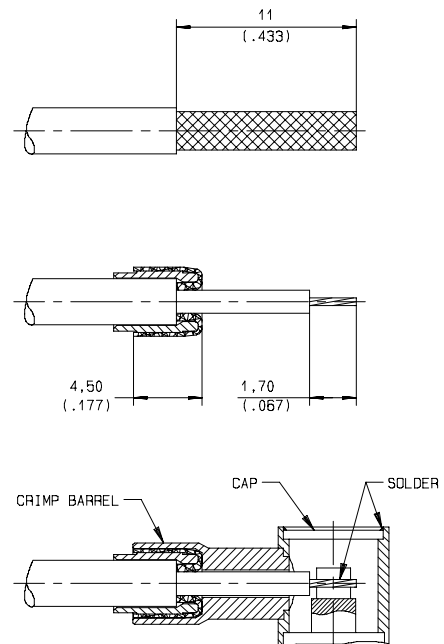

CODE S

- 1 - Put the sealing boot and the shield termination ferrule over the coax cable.
- 2 - Remove $.354 \pm .010$ of the cable jacket.
- 3 - Fold the round braid and the flat braid over the cable jacket. If necessary, separate the strands of the flat braid and make the strands straight before you fold them back.
- 4 - Remove $.260 \pm .010$ of the dielectric.
- 5 - Put the rear insulation bushing over the center conductor. Push the rear insulation bushing until it touches the shield braids.
- 6 - Put the center contact on the center conductor. Make sure that all the strands of the center conductor enter the crimp barrel of the center contact. Push the center contact until it touches the insulator bushing. Make sure that you see the conductor strands through the inspection hole in the center contact. Use a M22520/2-01 crimping tool with a DANIELS K345 locator to crimp the center contact to the center conductor.
 - selector : 5 for Boeing cable S280W503-1
 - selector : 6 for Boeing cable S280W503-2
 - selector : 6 for Raychem cable 5021K1011
- 7 - Push the shield termination ferrule forward until it touches the shield braids that touch the insulator bushing.
- 8 - Put the shield braids symmetrically around the shield termination ferrule. Cut the shield braids at $.040$ from the edge of the shield termination ferrule.
- 9 - Push the cable and center contact assembly into the outer contact assembly until it stops. Crimp the outer contact with M22520/5-01 crimping tool with M22520/5-45 die set, position B, or a M22520/10-01 with a M22520/10-23

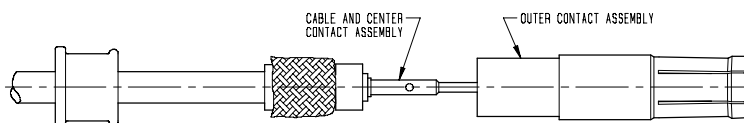
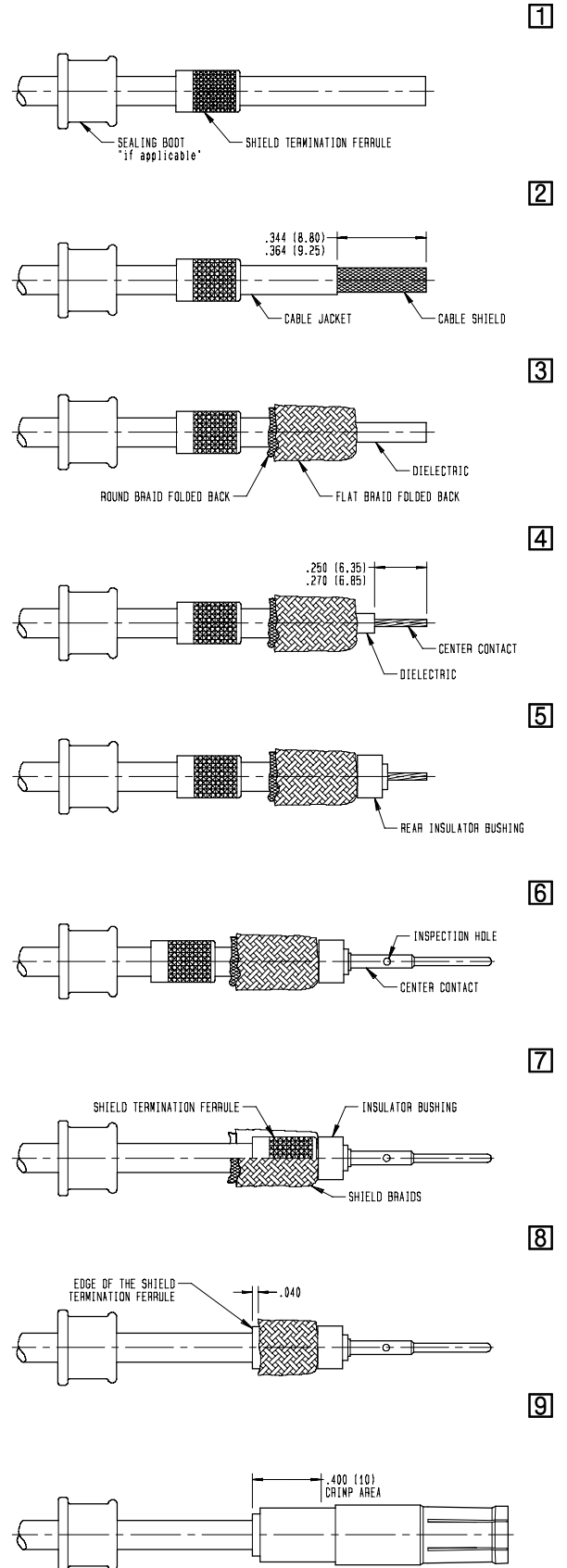

P/N	Pages	P/N	Pages	P/N	Pages	P/N	Pages
610020001	47, 48	616003	13	616125	14	616311	11, 45
610022001	47	616004	13	616126	34	616323	12
610026	47, 48	616005	13, 47	616127	36	616330	11, 45
610040	48	616006	13, 47	616128	14	616331	11, 45
610044	48	616007	13	616140	15	616340	11, 45
610046	48	616009	13, 47	616141	15	616361	11
610047	48	616013	13	616142	15	616366	11
610049	48	616014	13, 47	616143	15	616379	12, 45
610108	47	616015	13	616144	15	616910	24
610118	47	616020	14	616150	15	616911	24
610119	47	616021	14	616151	15	616912	24
610120	14, 47, 48	616022	14	616153	15	616913	24
610122	47	616022002	14	616154	15	616914010	24
610123	47	616023	14	616163	14	616915	24, 48
610126	14, 47, 48	616024	14	616192	36	616917	24, 48
610127	47	616026	14	616195000	16	616923	24, 48
610132	47	616028	14	616195001	16	616924	24
610140	48	616030	14	616195003	17	618050	15
610146	48	616031	14	616195004	16	618053	15
610147	48	616032	14	616195005	16	618054	15
610148	48	616040	15	616195007	16	620280	11
610149	48	616041	15	616195008	17	620281	11
610203	12, 46	616042	15	616195009	16	620290	11
610204	12, 46	616043	15	616195012	16	620291	11
610214	12, 46	616044	15	616196001	16	620351	36
610215	46	616090	36	616196003	16	620352	36
610216	45	616091	36	616196004	16	620361	36
610217	46	616092	36	616196005	17	620380	11
610219	45	616095000	16	616196007	17	620381	11
610220	45	616095001	16	616200	11, 45	620390	11
610221	45	616095004	16	616201	11, 45	620391	11
610224	46	616095005	16	616206	12, 45	620920	24, 48
610225	46	616095007	16	616210	11, 45	620922	24, 48
610226	45	616095009	16	616211	11, 45	620925	24
610228	46	616095010	16	616216	12	925.05.450	24
610303	12, 46	616096001	16	616220	36	925.05.460	24
610304	12, 46	616096002	16	616222	36	925.05.470	24
610314	12, 46	616096003	16	616223	12	925.05.480	24
610321	45	616096004	16	616224	36	925.05.490	24
610324	46	616096006	16	616230	11, 45	925.05.590	24
610325	45	616100	13	616231	11, 45	925.05.591	24
610803	24	616102001	13	616234	36	925.05.592	24
610804	24	616103001	13	616235	36	925.05.593	24
610805	24	616107001	13	616235010	36	925.05.594	24
610806	24	616111	13	616240	11, 45	F724002000	12
610900	25	616112	13	616261	11	F724005000	12
610901	25	616113	13	616266	11	F724041000	12
610902	25	616120	14	616300	11, 45	F724044000	12
610906	25	616121	14	616301	11, 45	F724045000	12
610910	25	616122	14	616303	12, 45	F724104000	12
610911	25	616123	14	616306	12, 45	F724241200	12
610941	24, 48	616124	14	616310	11, 45		



Radiall.com

- Sales & production subsidiary
- ▲ Industrial site
- Sales subsidiary

RADIALL WORLDWIDE LOCATIONS

EUROPE

France - RADIALL HEADQUARTERS

101, Rue Ph. Hoffmann - 93116 ROSNY sous BOIS (Paris)
 Tel. : +33 1 49 35 35 35 Fax : +33 1 48 54 63 63
 E-Mail : info@radiall.com

Finland - RADIALL SF

P.O. Box 202 - 90101 OULU
 Tel. : +358 407 522 412
 E-Mail : infofi@radiall.com

Germany - RADIALL GmbH

Carl-Zeiss Str. 10 Postfach 200143 - D63307 RÖDERMARK (Frankfurt)
 Tel. : +49 60 74 91 07 0 Fax : +49 60 74 91 07 70
 E-Mail : info@radiall.com
 Regional office : Munich

Italy - RADIALL Elettronica SRL

Via Concordia, 5 - 20090 ASSAGO MILANO
 Tel. : +39 02 48 85 121 Fax : +39 02 48 84 30 18
 E-Mail : infoit@radiall.com
 Regional office : Roma

Netherlands - RADIALL BV

Hogebrinkerweg 15b - 3871 KM HOEVELAKEN
 Tel. : +31 33 253 40 09 Fax : +31 33 253 45 12
 E-Mail : infofl@radiall.com

Sweden - RADIALL AB

Sjöängsvägen 2 - SE-192 72 SOLLENTUNA (Stockholm)
 Tel. : +46 844 434 10 Fax : +46 875 449 16
 E-Mail : infose@radiall.com

U.K. - RADIALL Ltd

Ground Floor, 6 The Grand Union Office Park, Packet Boat Lane
 UXBRIDGE Middlesex UB8 2GH (London)
 Tel. : +44 1895 425 000 Fax : +44 1895 425 010
 E-Mail : infouk@radiall.com

AMERICA

North America

RADIALL

6825 West Galveston Street Suite 11
 CHANDLER, Arizona 85226, USA
 Tel. : +1 480 682 9400 Fax : +1 480 682 9403
 E-Mail : infousa@radiall.com

RADIALL-AEP

104 John W. Murphy Drive
 NEW HAVEN, Connecticut 06513
 Tel. : +1 203 776 2813 Fax : +1 203 776 8294
 E-Mail : aeppales@aep.us

Brazil

RADIALL do Brasil

Largo do Machado, 54 sala 706 - Catete
 22221-020 RIO DE JANEIRO
 Tel. : +55 21 2558 05 76 Fax : +55 21 2245 97 63
 E-Mail : infobr@radiall.com

ASIA

China - SHANGHAI RADIALL Electronic Co., Ltd

N° 390 Yong He Road 200072 - SHANGHAI
 Tel. : +86 21 66 52 37 88 Fax : +86 21 66 52 11 77
 E-Mail : infozh@radiall.com

Japan - NIHON RADIALL

Shibuya-ku Ebisu 1-5-2, Kougetsu Bldg 405-TOKYO 150-0013
 Tel. : +81 3 3440 6241 Fax : +81 3 3440 6242
 E-Mail : infojp@radiall.com

HongKong - RADIALL Electronics Ltd

Elite Industrial Centre, Room 212, 2/F
 N° 883 Cheung Sha Wan Road - KOWLOON HONG KONG
 Tel. : +852 29 59 38 33 Fax : +852 29 59 26 36
 E-Mail : infohk@radiall.com

India - RADIALL PROTECTRON pvt Ltd

25 D, II Phase, Peenya Industrial Area - BANGALORE. 560058
 Tel. : +91 80 23 72 09 89 Fax : +91 80 28 39 72 28
 E-Mail : infoin@radiall.com

REPRESENTED IN

Africa	Greece	Russia	Thailand
Australia	Israel	Singapore	Taiwan
Belgium	Malaysia	Spain	Turkey
China	Philippines	South Africa	USA
Denmark	Poland	South Korea	
France	Portugal	Switzerland	

For the above countries, please contact the local agent or RADIALL at info@radiall.com

D7C00CE - 2008 June Edition

RADIALL 
 The next connexion

Printed in France

This information is intended as a guide only. To ensure a continuing policy of product improvement, Radiall reserves the right to modify its specifications without prior notification.