

MEMORY CARD CONNECTORS (PCMCIA CONFORMABLE) SURFACE MOUNT

560H SERIES - LIGHTWEIGHT

■ FEATURES

- The connectors conform to the Japan Electronic Industry Development Association (JEIDA) and Personal Computer Memory Card International Association (PCMCIA) standards Ver. 4.
- Contact pitch of 1.27 mm (0.050 in.) x 1.27 mm (0.050 in.). Incorrect insertion is prevented. Hot system plugging is possible (contact detection).
- Plugs have an easy-to-use ejection mechanism.
- Raised mounting type connectors (under which components can be mounted) and low-profile connectors are available.
- In addition to connectors for type I and type II cards, a connector for type III cards has been provided.
- The sockets are of the SMT type. A straddle-type socket for double-sided mounting and a socket for single-sided mounting are available.

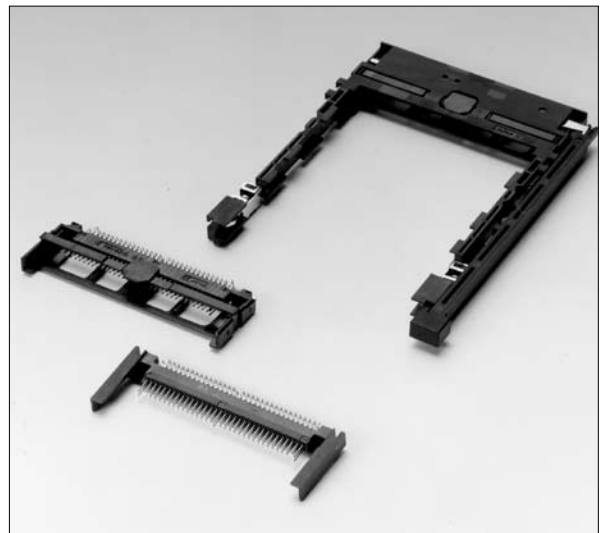

■ SPECIFICATIONS

Item	Specification
Operating temperature range	-55°C to +85°C
Current rating	DC 0.5 A
Voltage rating	AC 250 V
Contact resistance	40 mΩ max (6 VDC, 0.1 A)
Insulation resistance	1000 MΩ min. (500 VDC)
Dielectric withstanding voltage	500 VAC for 1 minute
Insertion/withdrawal life	Industrial environment: 5,000 times Office environment: 10,000 times

■ PIN CONNECTOR (PLUG) CONTACT LENGTH

Contact type	Pin No.	Contact length
Power, ground pins	1, 17, 34, 35, 51, 68	5.0 mm (0.196 in.)
Card detection pins	36, 67	3.5 mm (0.137 in.)
Other signal pins	Others	4.25 mm (0.167 in.)

■ MATERIALS

Item	Specification
Insulating material	Plug body: PPS resin UL94V-0 : 6T nylon (for type III card connector) UL94V-0 Ejector: Polyester : PPS resin (for SMT and type III card connectors)
Conductor	Copper alloy
Plating	Contact: Gold over palladium over nickel (PAGOS) Terminal: Palladium

560H Series Connector Conforming to Ver. 4

■ ORDERING PART NUMBER [PLUG]

FCN-56 5 P 068-G / XC-V4

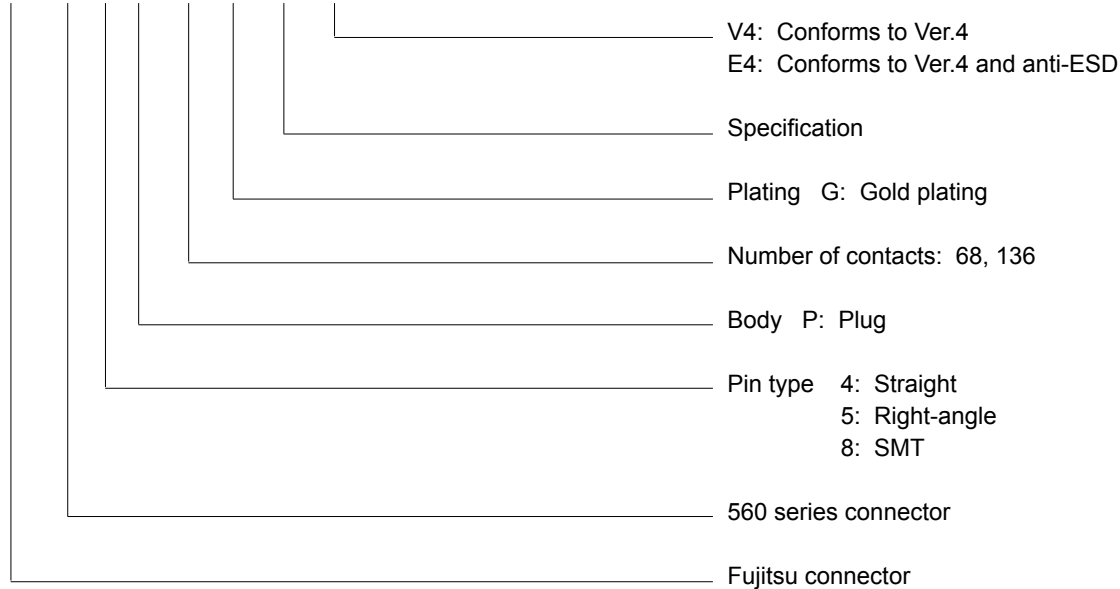

■ ORDERING PART NUMBER [SOCKET]

FCN-56 8 J 068-G / 0

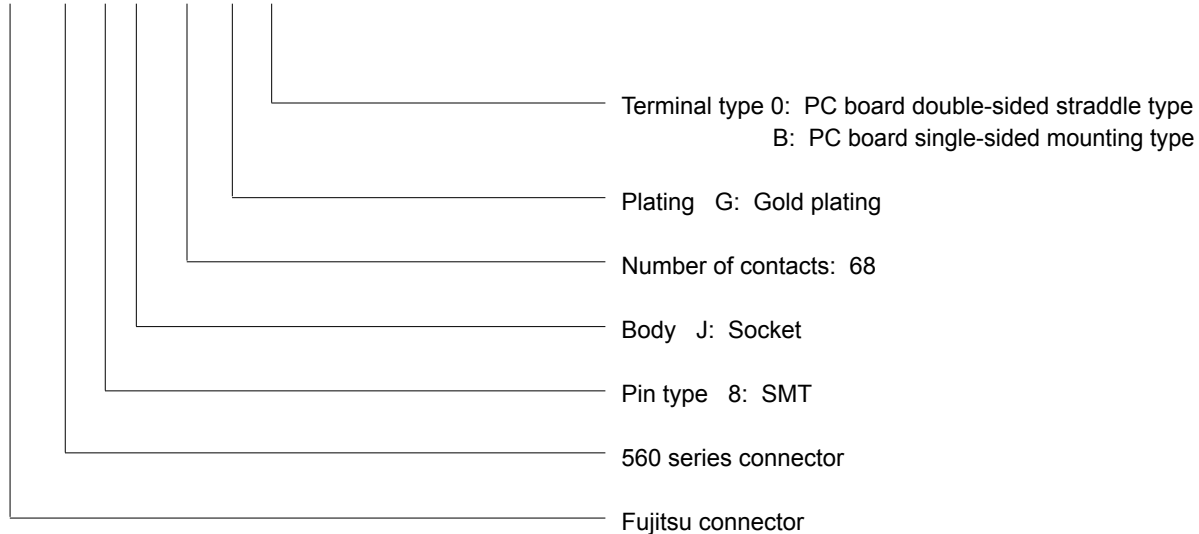

560H Series Connector Conforming to Ver. 4

TYPE 1 ~ III CARD SUPPORT

RIGHT-ANGLE PLUG, SMT LIGHT WEIGHT TYPE (WITH RIGHT-BUTTON EJECTOR, WITH FG CLIP)

Part number: FCN-568P068-G/0563-4E (for 5V Card)
 FCN-568P068-G/0963-4E (3.3 V card support)

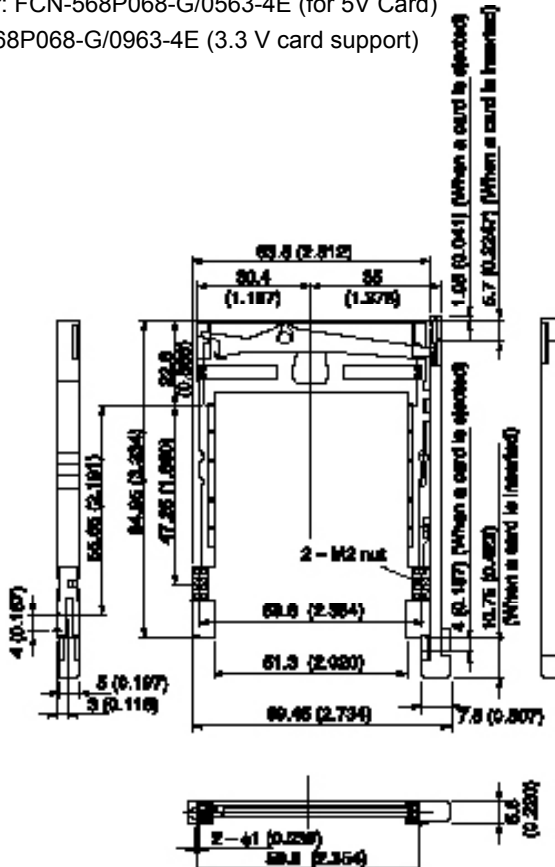

Main body

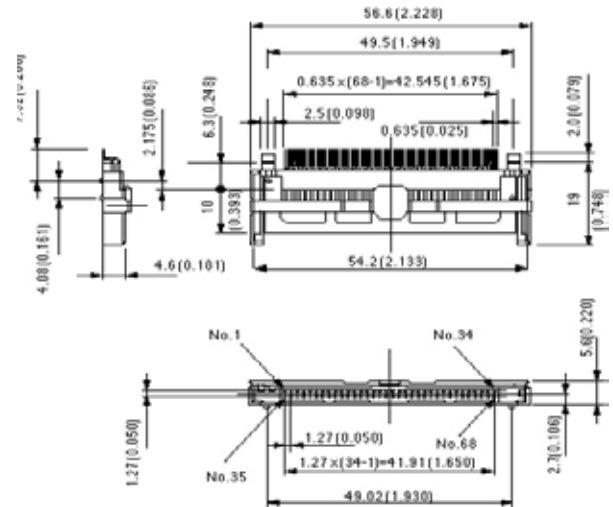

Material
 connector main body: PPS
 guide: PBT
 button: ABS

Unit: mm (in.)

• Connector main body and ejector are shipped separately.

PC BOARD MOUNTING PATTERN (MOUNTING SIDE)

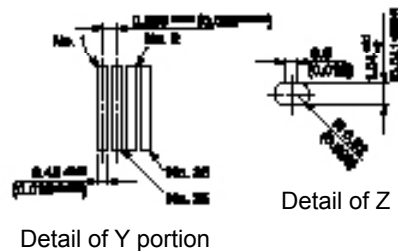
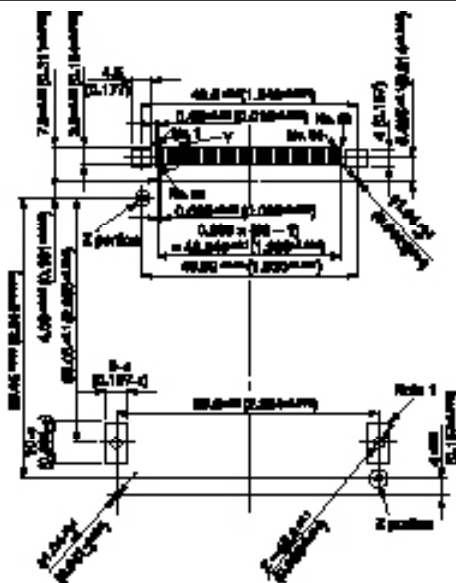

Detail of Z portion

Detail of Y portion

Note 1: Ground pattern

: mm (in.)

560H Series Connector Conforming to Ver. 4

TYPE 1 ~ III CARD SUPPORT

RIGHT-ANGLE PLUG, SMT LIGHT WEIGHT TYPE (WITH LEFT-BUTTON EJECTOR, WITH FG CLIP)

■ DIMENSIONS (FOR 5V CARD/3.3V CARD)

Part number: FCN-568P068-G/0564-4E (for 5V card)
 FCN-568P068-G/0964-4E (3.3V card support)

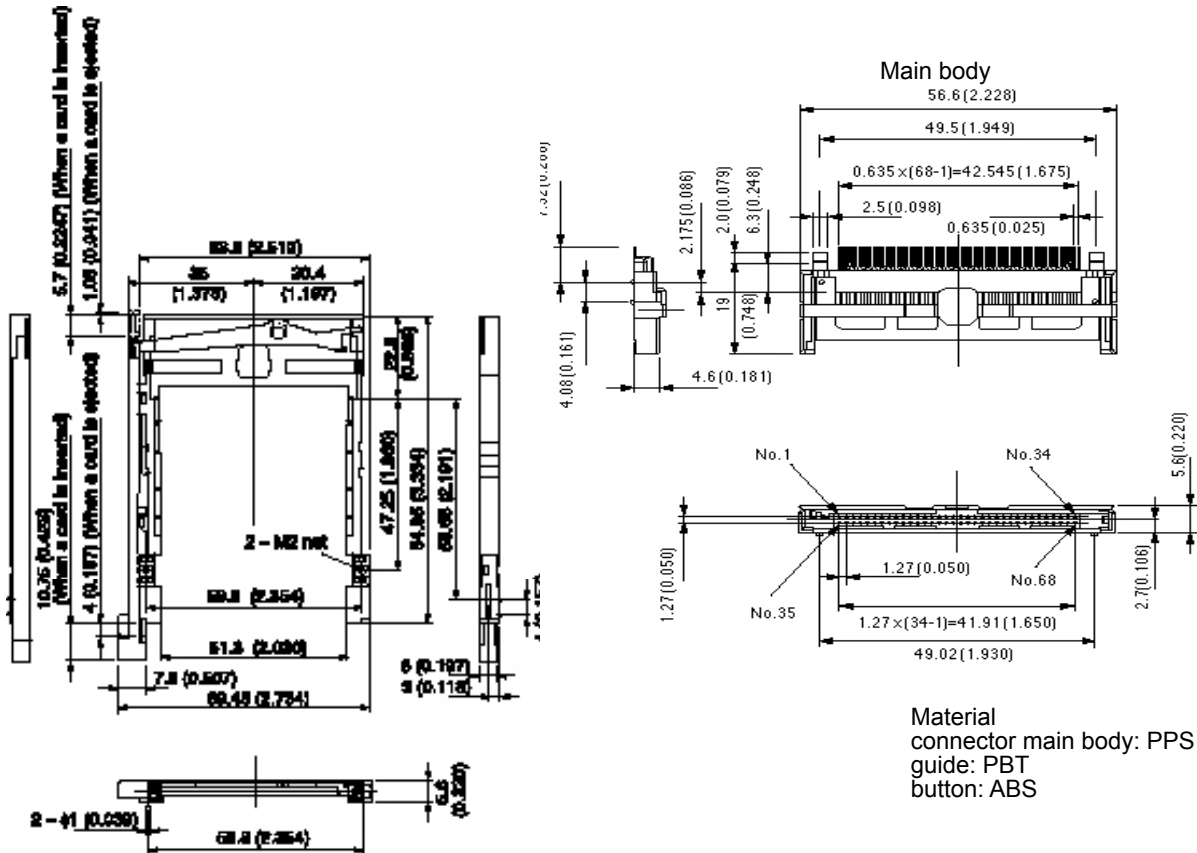

• Connector main body and ejector are shipped separately.

Unit: mm (in.)

■ PC BOARD MOUNTING PATTERN (MOUNTING SIDE)

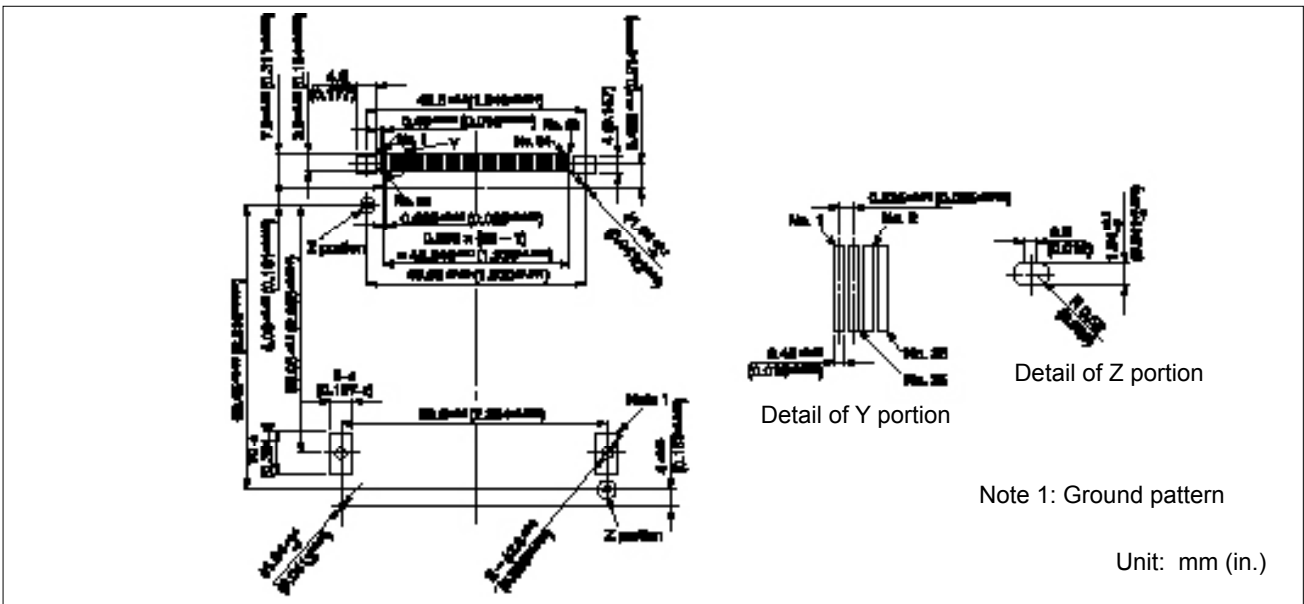

560H Series Connector Conforming to Ver. 4

TYPE 1 ~ III CARD SUPPORT

RIGHT-ANGLE PLUG, SMT LIGHT WEIGHT TYPE (WITH RIGHT-BUTTON EJECTOR, WITH FG CLIP, TO BE MOUNTED ON BACK OF PC BOARD)

■ DIMENSIONS (FOR 5V CARD/3.3V CARD)

Part number: FCN-568P068-G/0663-4E (for 5V card)
FCN-ε

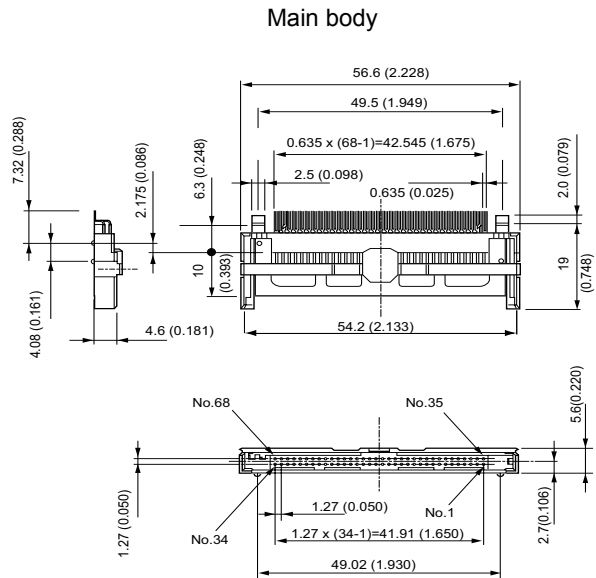
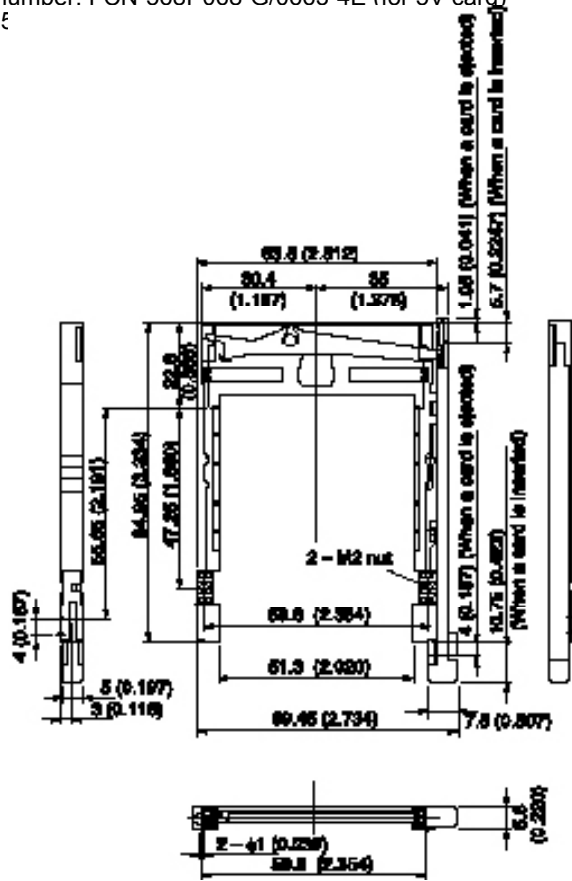

Material
connector main body: PPS
guide: PBT
button: ABS

• Connector main body and ejector are shipped separately.

Unit: mm (in.)

■ PC BOARD MOUNTING PATTERN (MOUNTING SIDE)

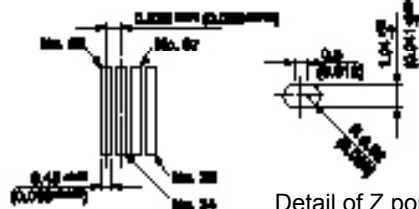
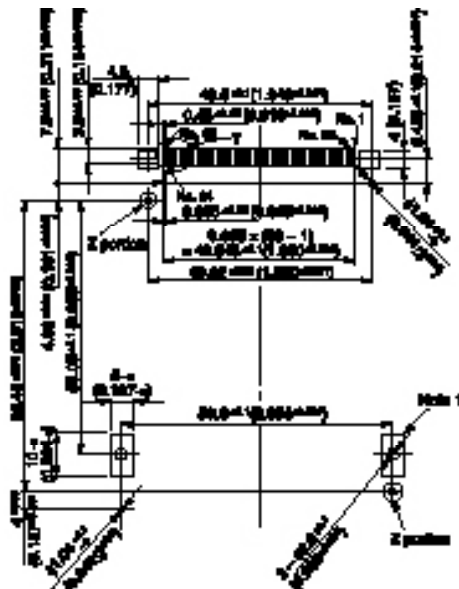

Detail of Z portion

Detail of Y portion

Note 1: Ground pattern

Unit: mm (in.)

560H Series Connector Conforming to Ver. 4

TYPE 1 ~ III CARD SUPPORT

RIGHT-ANGLE PLUG, SMT LIGHT WEIGHT (WITH LEFT-BUTTON EJECTOR, WITH FG CLIP, TO BE MOUNTED ON BACK IF PC BOARD)

Part number: FCN-568P068-G/0664-4E (for 5V card)
 FCN-568-P068-G/1064-4E (3.3V card support)

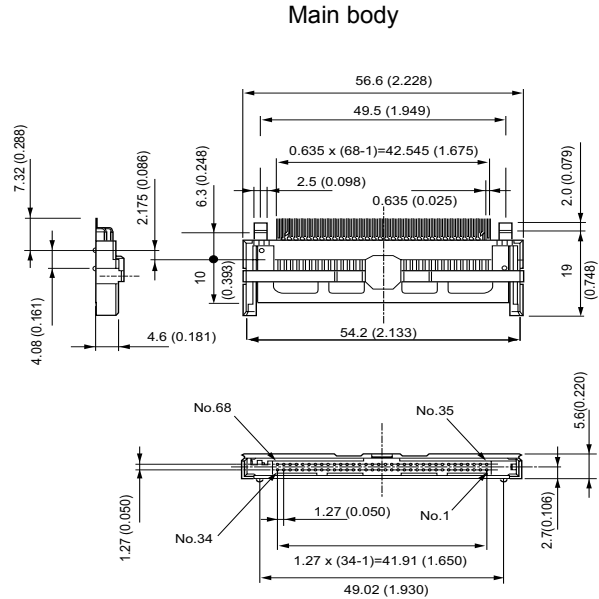
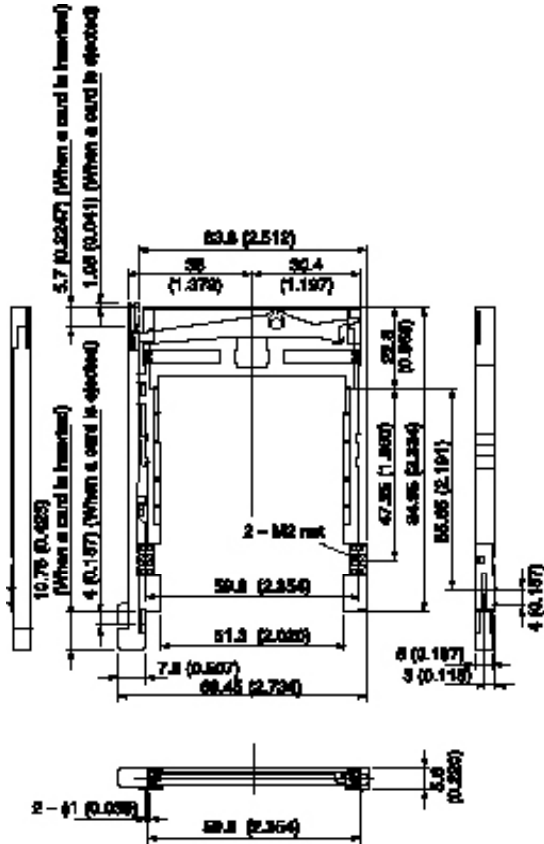

Material
 connector main body: PPS
 guide: PBT
 button: ABS

• Connector main body and ejector are shipped separately.

Unit: mm (in.)

■ PC BOARD MOUNTING PATTERN (MOUNTING SIDE)

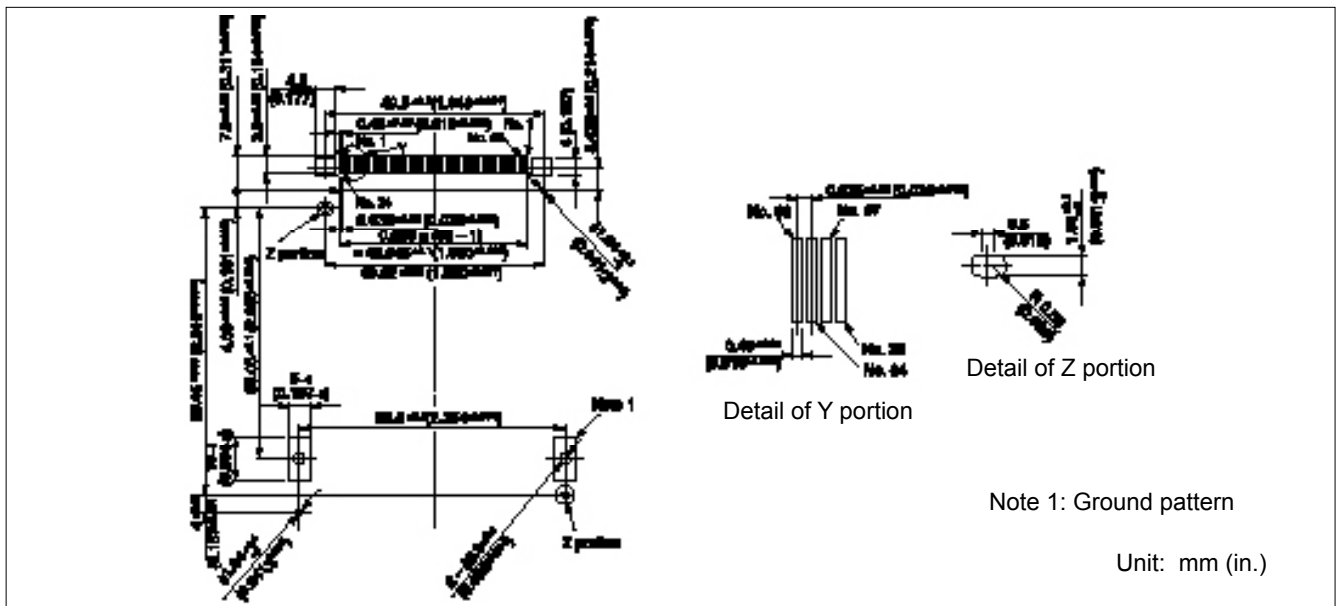

560H Series Connector Conforming to Ver. 4

TYPE 1 ~ III CARD SUPPORT

RIGHT-ANGLE PLUG, SMT LIGHT WEIGHT TYPE (WITH RIGHT -BUTTON EJECTOR, 2 mm RAISED TYPE, WITH FG CLIP)

■ DIMENSIONS (FOR 5V CARD/3.3V CARD)

Part number: FCN-568P068-G/0770-4E (for 5V card)
 Part number: FCN-568P068-G/1170-4E (3.3V card support)

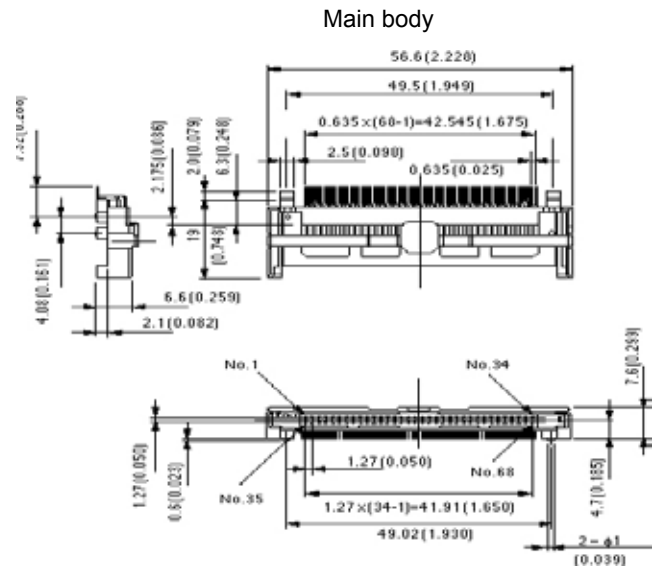
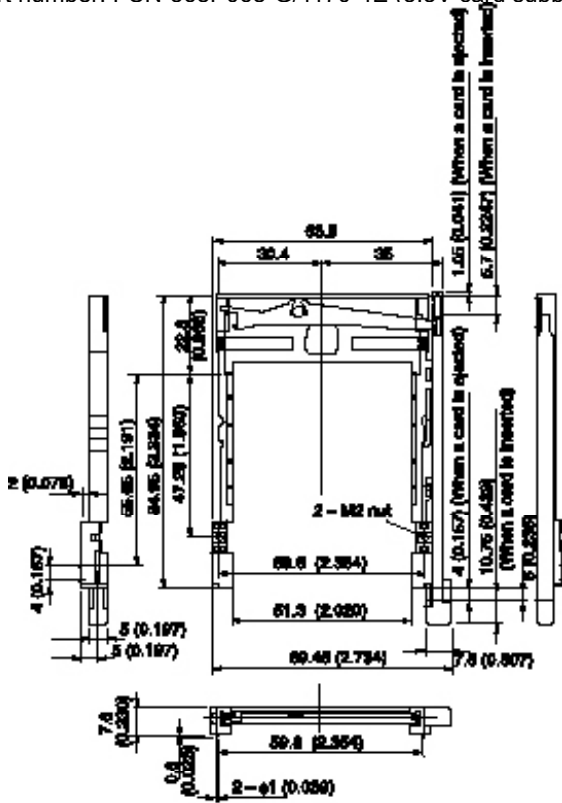

Material
 connector main body: PPS
 guide: PBT
 button: ABS

Unit: mm (in.)

• Connector main body and ejector are shipped separately.

■ PC BOARD MOUNTING PATTERN (MOUNTING SIDE)

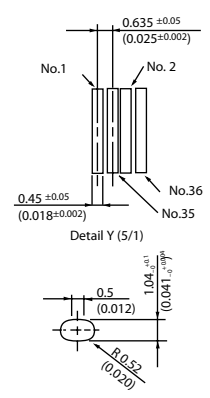
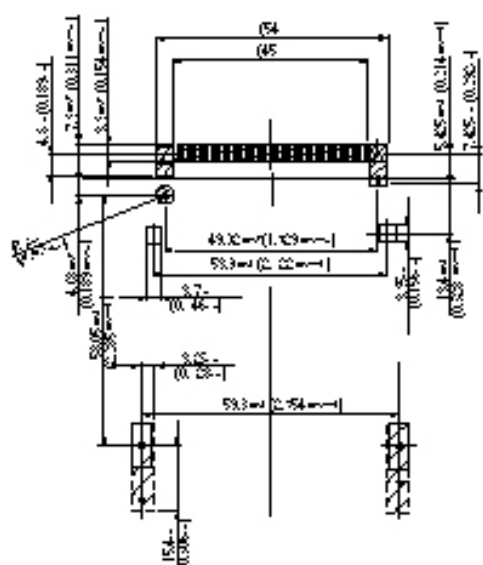
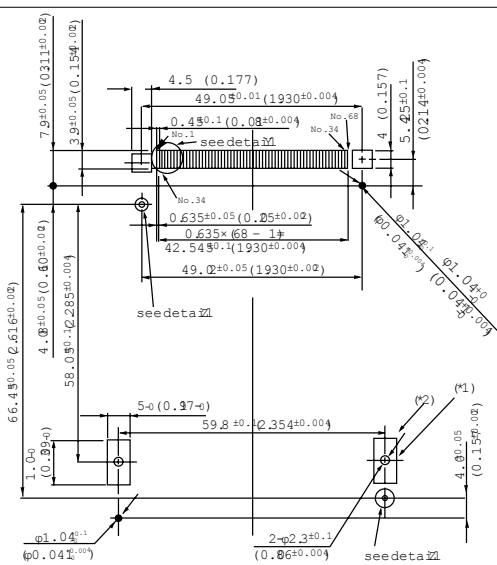

Unit: mm (in.)

Note 1: Use 6mm long screws, screw torque is 2kg/cm

Note 2: Ground pattern

Note 3: Drawing is for the type to be inserted on the front of PCB

Note 4: In hatched area component mounting is prohibited

560H Series Connector Conforming to Ver. 4

TYPE 1 ~ III CARD SUPPORT

RIGHT-ANGLE PLUG, SMT LIGHT WEIGHT TYPE (WITH LEFT-BUTTON EJECTOR, 2 mm RAISED TYPE, WITH FG CLIP)

■ DIMENSIONS (FOR 5V CARD/3.3V CARD)

Part number: FCN-568P068-G/0771-4E (for 5V card)
 Part number: FCN-568P068-G/1171-4E (3.3V card support)

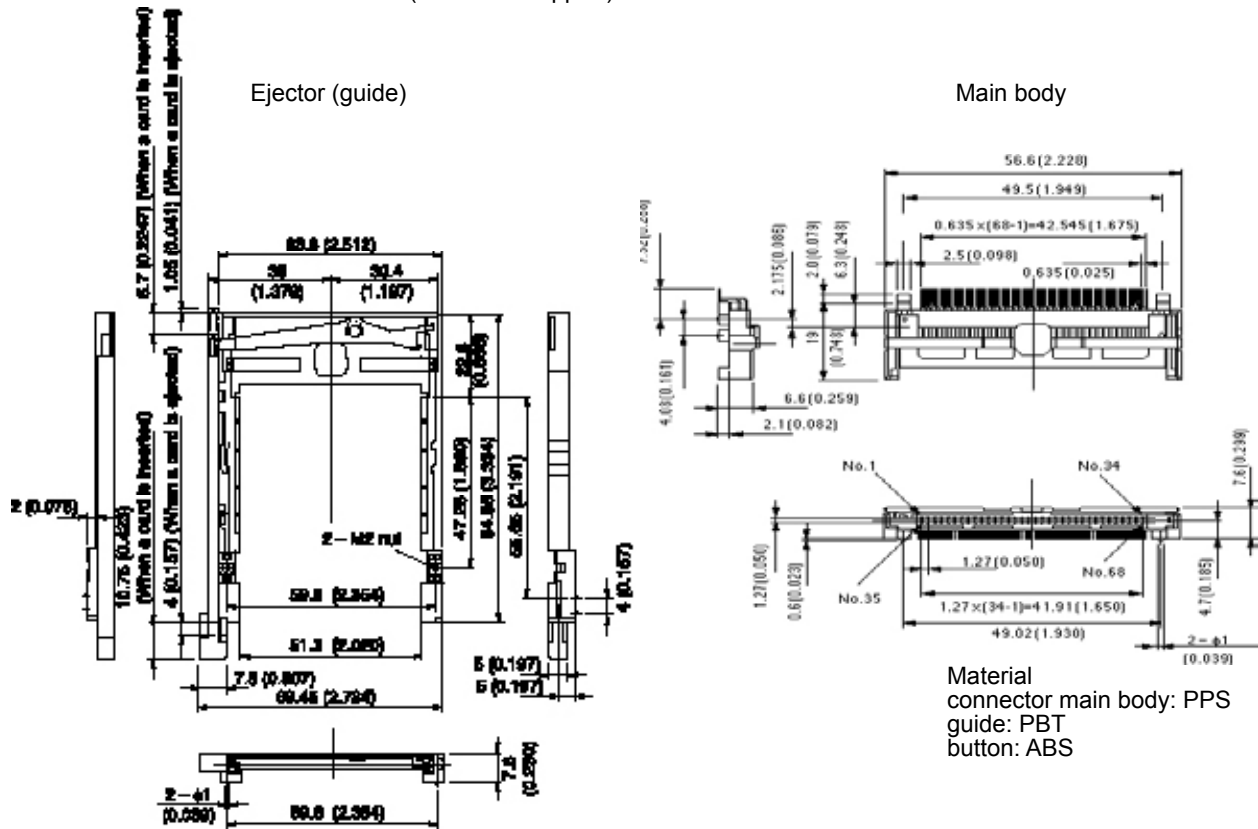

• Connector main body and ejector are shipped separately.

Unit: mm (in.)

■ PC BOARD MOUNTING PATTERN (MOUNTING SIDE)

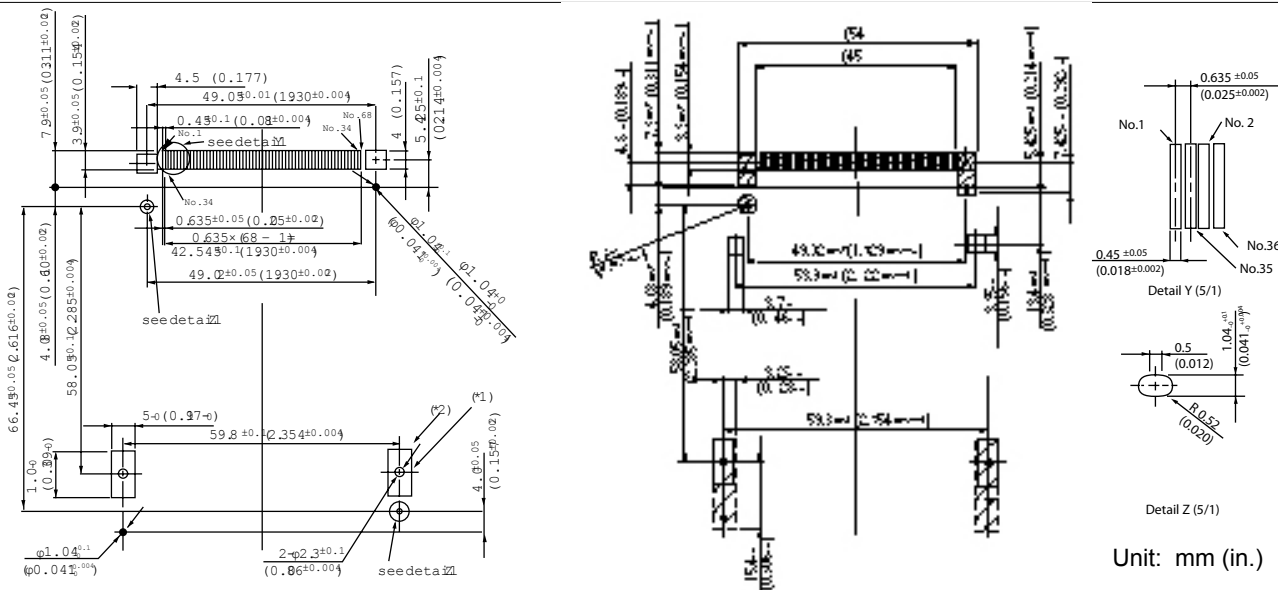

Note 1: Use 6mm long screws, screw torque is 2kg/cm
 Note 2: Ground pattern

Note 3: Drawing is for the type to be inserted on the front of PCB
 Note 4: In hatched area component mounting is prohibited

560H Series Connector Conforming to Ver. 4

TYPE 1 ~ III CARD SUPPORT

RIGHT-ANGLE PLUG, SMT LIGHT WEIGHT TYPE (WITH RIGHT-BUTTON EJECTOR, 2 mm RAISED TYPE, WITH FG CLIP, TO BE MOUNTED ON BACK OF PC BOARD)

■ DIMENSIONS (FOR 5V CARD/3.3V CARD)

Part number: FCN-568P068-G/0870-4E (for 5V card)
FCN-568P068-G1270-4E (3.3V card support)

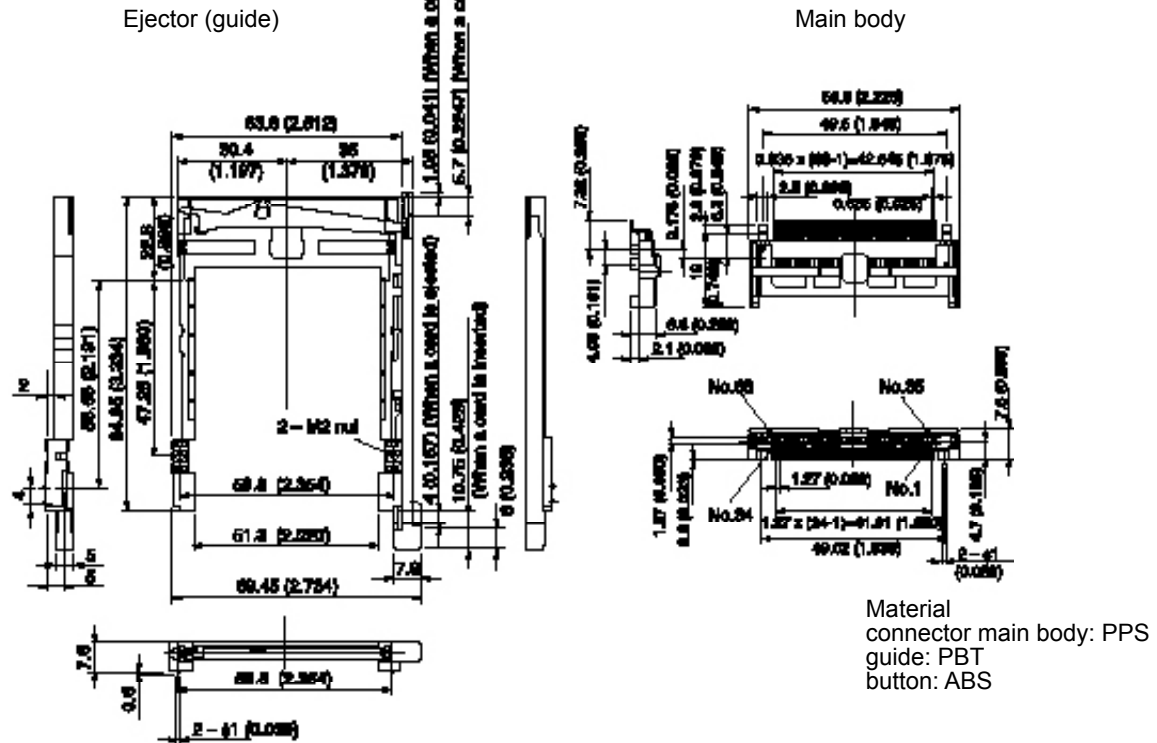

• Connector main body and ejector are shipped separately.

Unit: mm (in.)

■ PC BOARD MOUNTING PATTERN (MOUNTING SIDE)

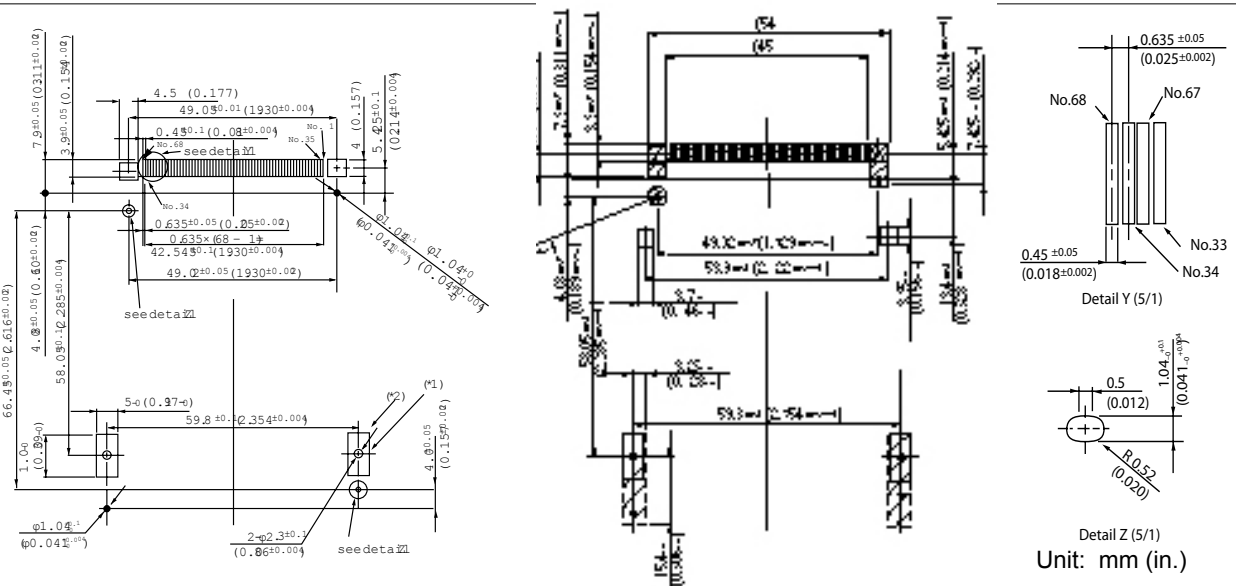

Note 1: Use 6mm long screws, screw torque is 2kg/cm
Note 2: Ground pattern

Note 3: Drawing is for the type to be inserted on the front of PCB
Note 4: In hatched area component mounting is prohibited

560H Series Connector Conforming to Ver. 4

TYPE 1 ~ III CARD SUPPORT

RIGHT-ANGLE PLUG, SMT LIGHT WEIGHT TYPE (GUIDE RAILS ONLY, 2.1 mm RAISED TYPE, WITH FG CLIP)

■ DIMENSIONS (FOR 5V CARD/3.3V CARD)

Part number: FCN-568P068-G/0773-4E (for 5V card)
FCN-568P068-G/1173-4E (3.3V card support)

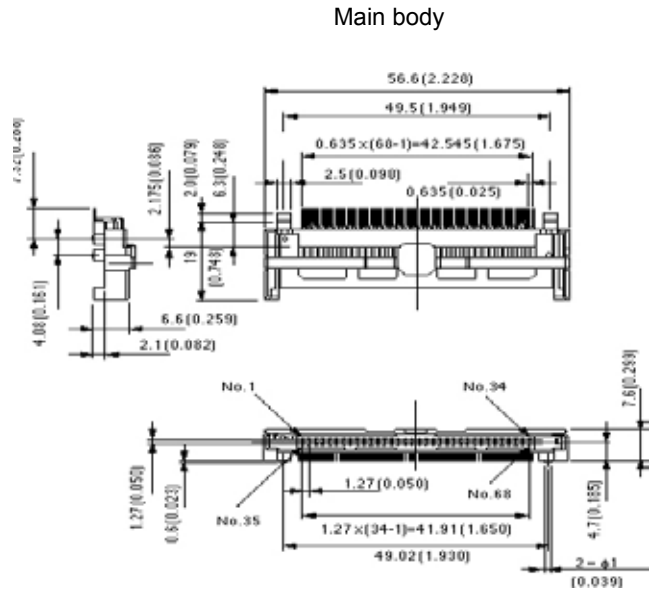
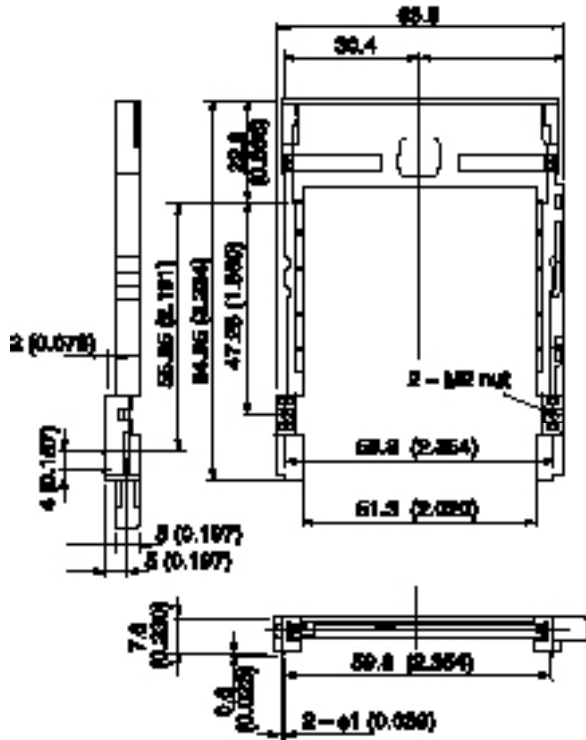

Main body

Material
connector main body: PPS
guide: PBT
button: ABS

Unit: mm (in.)

• Connector main body and ejector are shipped separately.

■ PC BOARD MOUNTING PATTERN (MOUNTING SIDE)

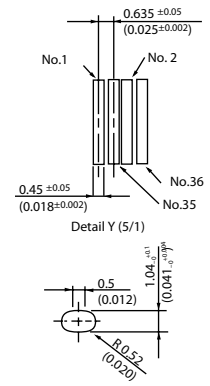
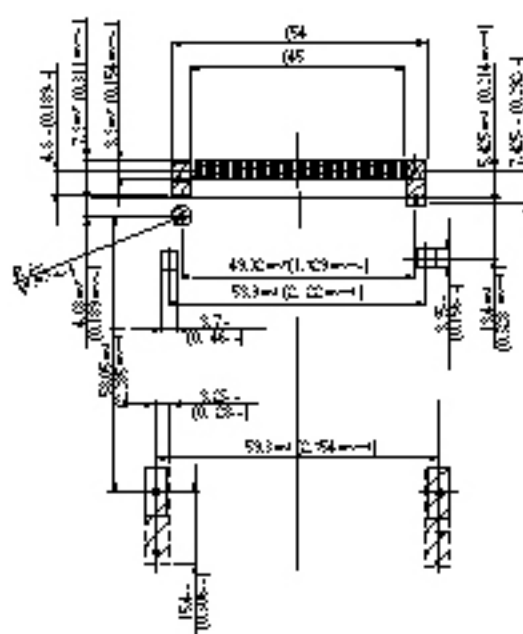
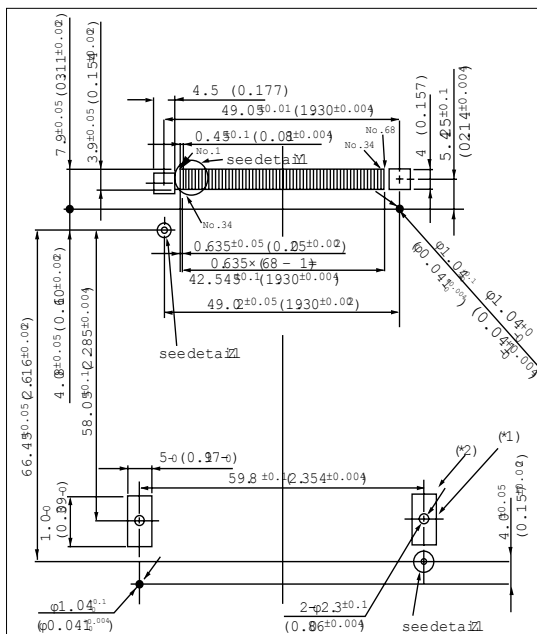

Detail Z (5/1)

Unit: mm (in.)

Note 1: Use 6mm long screws, screw torque is 2kg/cm
Note 2: Ground pattern

Note 3: Drawing is for the type to be inserted on the front of PCB
Note 4: In hatched area component mounting is prohibited

560H Series Connector Conforming to Ver. 4

TYPE 1 ~ III CARD SUPPORT

RIGHT-ANGLE PLUG, SMT LIGHT WEIGHT TYPE (WITH LEFT-BUTTON EJECTOR, 2 mm RAISED TYPE, WITH FG CLIP, TO BE MOUNTED ON BACK OF PC BOARD)

■ DIMENSIONS (FOR 5V CARD/3.3V CARD)

Part number: FCN-568P068-G/0871-4E (for 5V card)
FCN-568P068-G/1271-4E (3.3V card support)

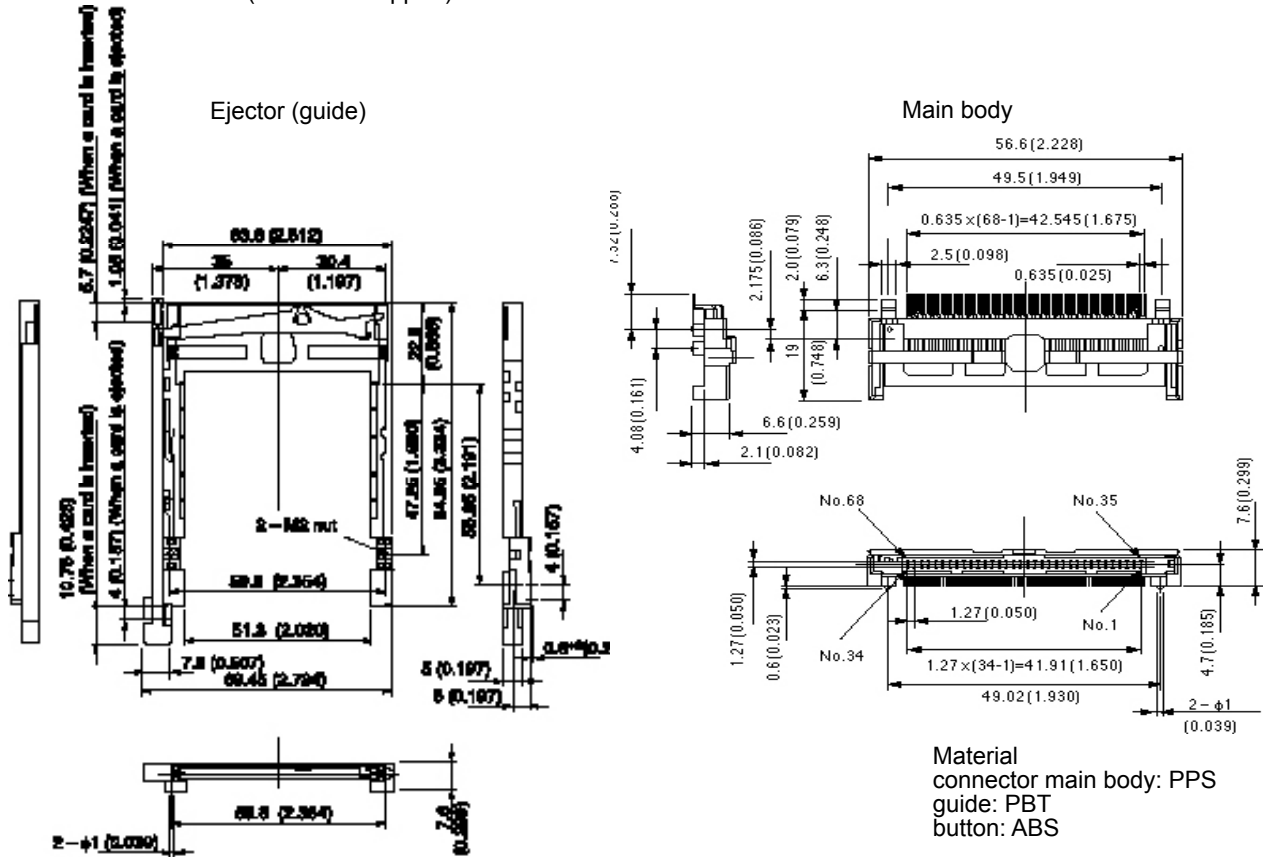

• Connector main body and ejector are shipped separately.

Unit: mm (in.)

■ PC BOARD MOUNTING PATTERN (MOUNTING SIDE)

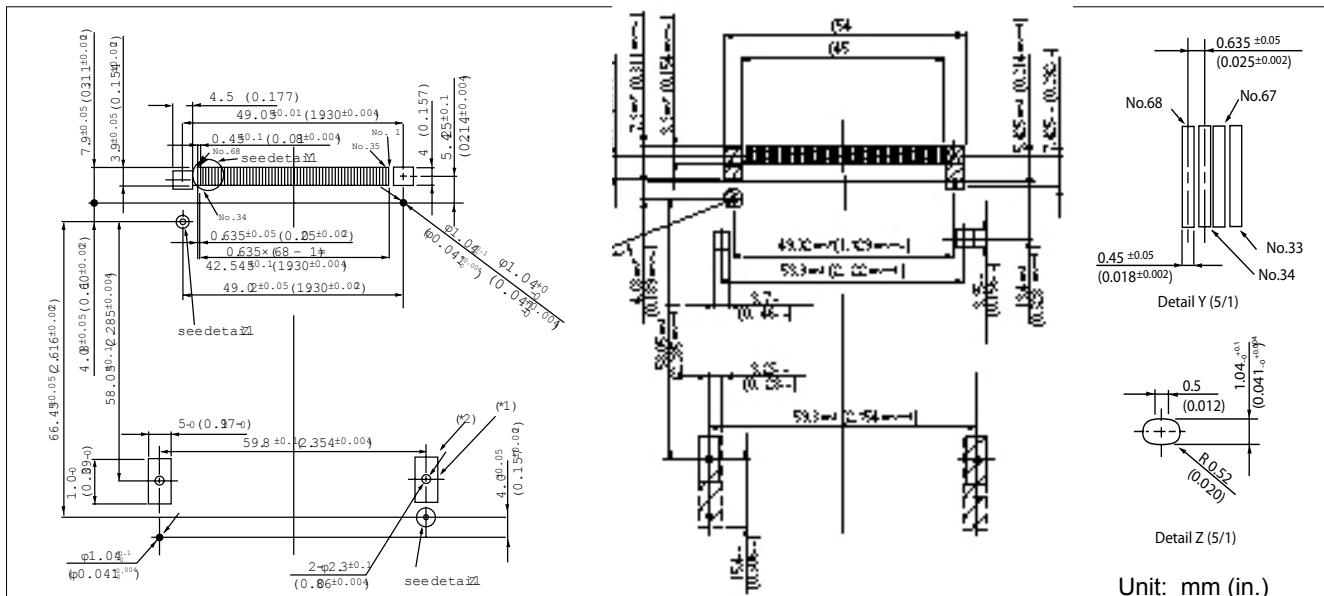

Note 1: Use 6mm long screws, screw torque is 2kg/cm
Note 2: Ground pattern

Note 3: Drawing is for the type to be inserted on the front of PCB
Note 4: In hatched area component mounting is prohibited

560H Series Connector Conforming to Ver. 4

CARD LOCK TYPE / TYPE 1 ~ III CARD SUPPORT

RIGHT-ANGLE PLUG, SMT LIGHT WEIGHT TYPE (WITH RIGHT-BUTTON EJECTOR, WITH FG CLIP)

Part number: FCN-568P068-G/0578-4E (for 5V card)
 FCN-568P068-G/0978-4E (for 3.3V card support)

Main body

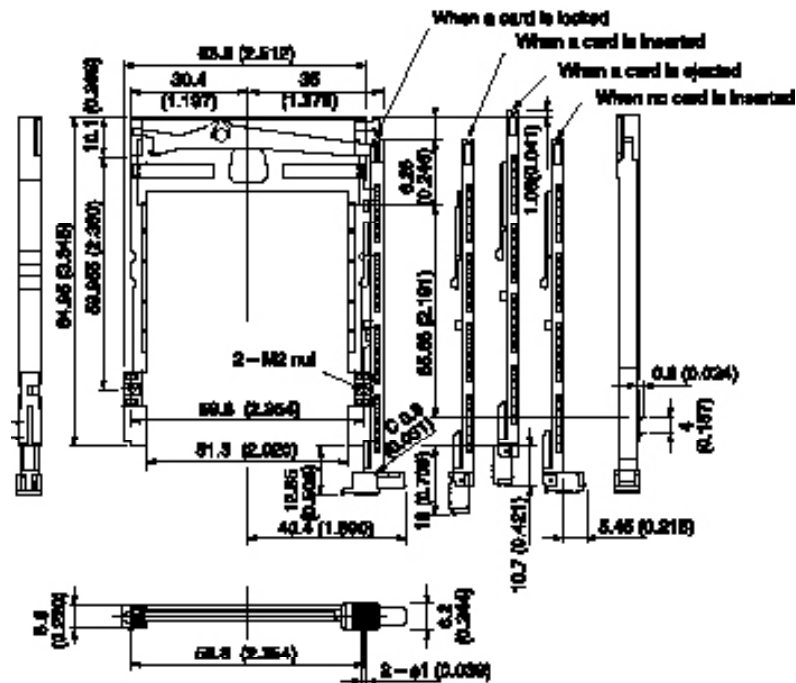
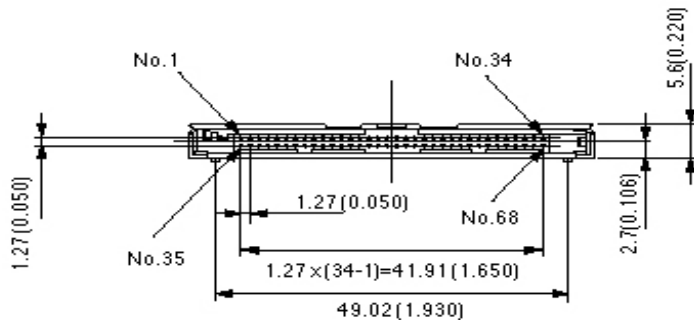
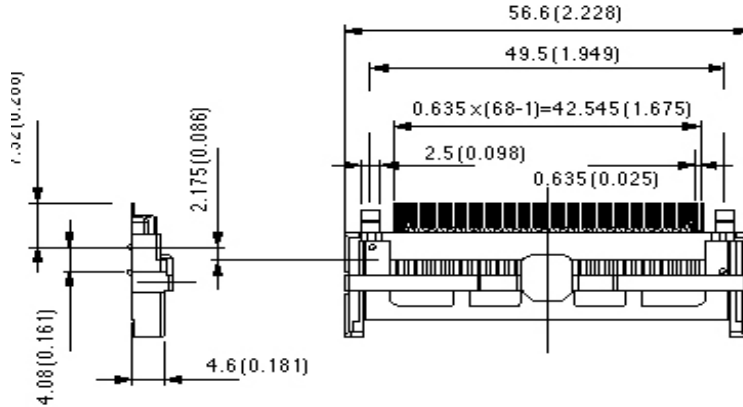

• Connector main body and ejector are shipped separately.

Unit: mm (in.)

560H Series Connector Conforming to Ver. 4

CARD LOCK TYPE / TYPE 1 ~ III CARD SUPPORT

RIGHT-ANGLE PLUG, SMT LIGHT WEIGHT TYPE (WITH RIGHT-BUTTON EJECTOR, WITH FG CLIP)

Part number: FCN-568P068-G/0578-4E (for 5V card)
 FCN-568P068-G/0978-4E (for 3.3V card support)

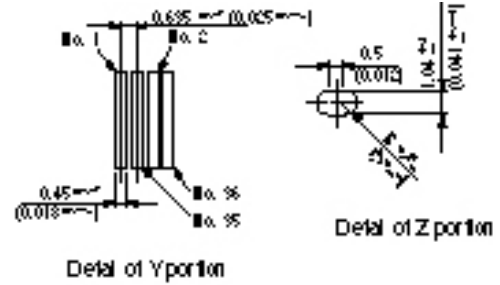
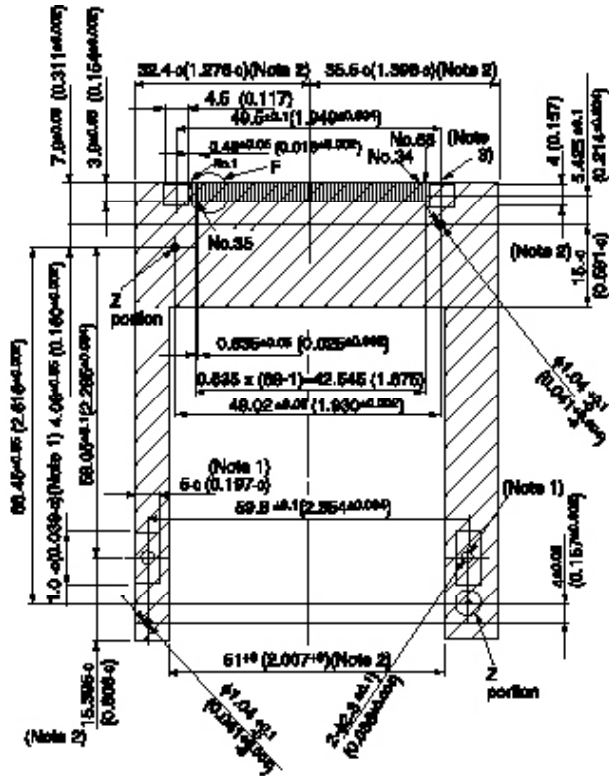

- Note 1: Pattern
- Note 2: In hatched areas, component mounting, VIA holes higher than PC board surface, and patterns are prohibited
- Note 3: Ground Pattern

Unit: mm (in.)

RECOMMENDED DIMENSION OF BODY (BUTTON AREA) ■ CARD LOCK METHOD

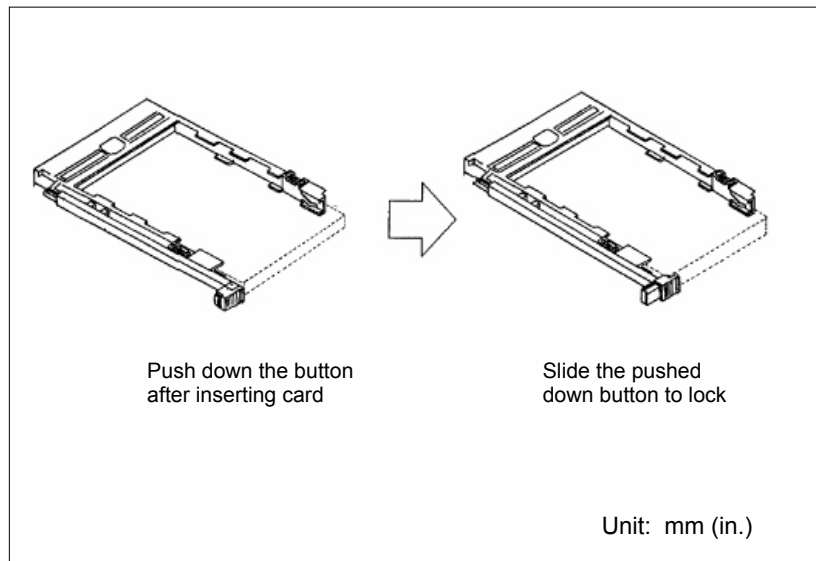
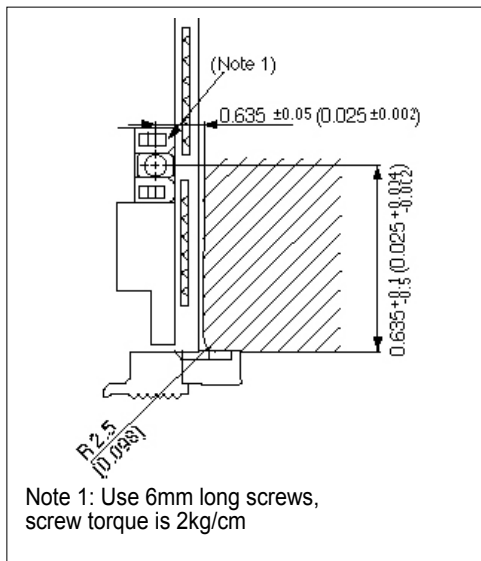

560H Series Connector Conforming to Ver. 4

CARD LOCK TYPE / TYPE 1 ~ III CARD SUPPORT

RIGHT-ANGLE PLUG, SMT LIGHT WEIGHT TYPE (WITH LEFT-BUTTON EJECTOR, WITH FG CLIP)

■ DIMENSIONS (FOR 5V CARD/3.3V CARD)

Part number: FCN-568P068-G/0579-4E (for 5V card)
 FCN-568P068-G/0974-4E (for 3.3V card support)

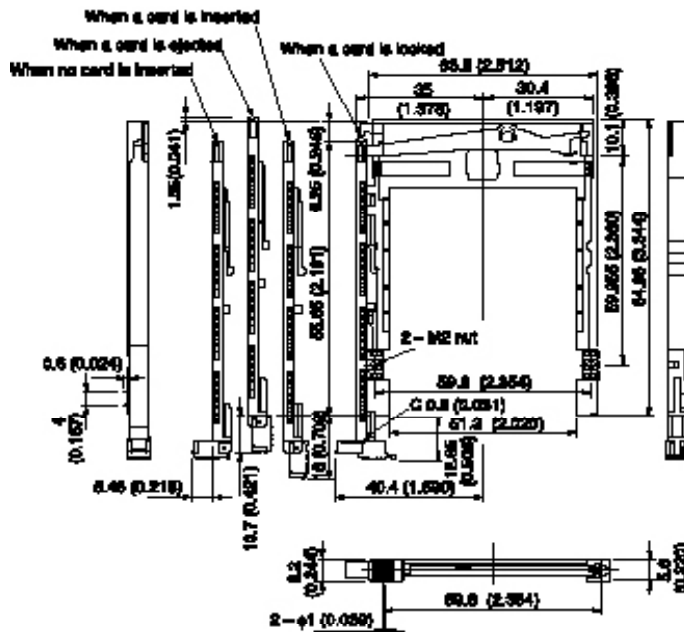
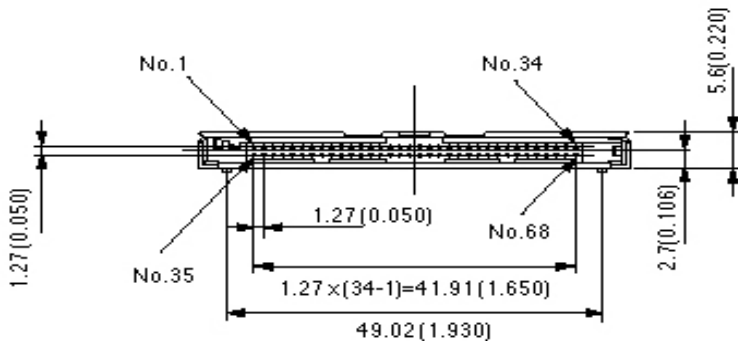
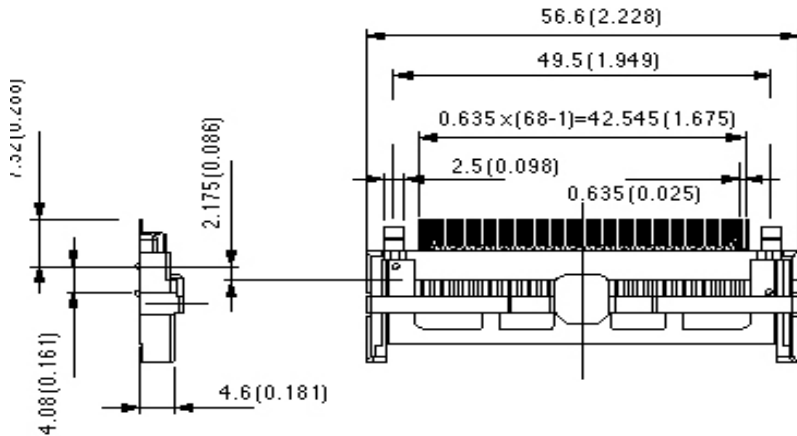
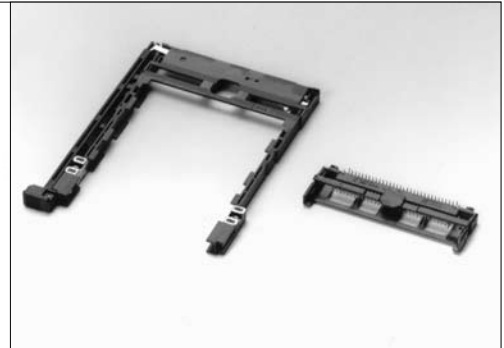

560H Series Connector Conforming to Ver. 4

CARD LOCK TYPE / TYPE 1 ~ III CARD SUPPORT

RIGHT-ANGLE PLUG, SMT LIGHT WEIGHT TYPE (WITH LEFT-BUTTON EJECTOR, WITH FG CLIP)

■ PC BOARD MOUNTING PATTERN (MOUNTING SIDE)

Part number: FCN-568P068-G/0579-4E (for 5V card)
FCN-568P068-G/0974-4E (for 3.3V card support)

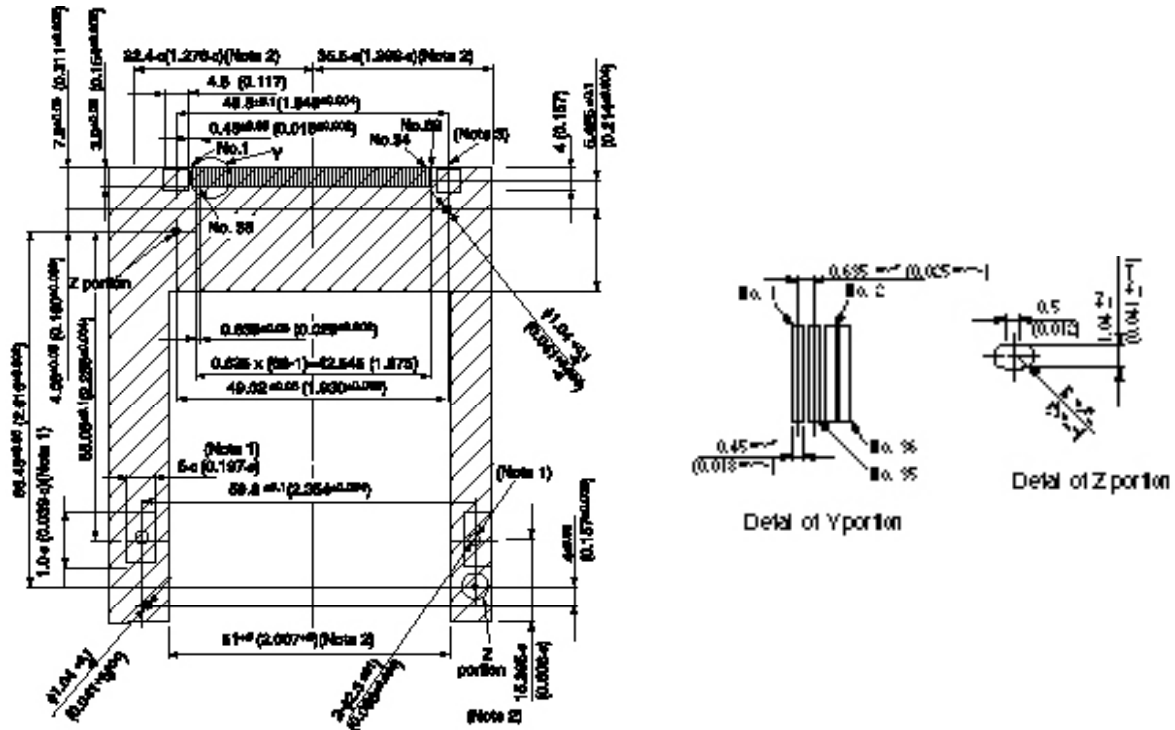

- Note 1: Pattern
- Note 2: In hatched areas, component mounting, VIA holes higher than PC board surface, and patterns are prohibited
- Note 3: Ground Pattern

Unit: mm (in.)

■ RECOMMENDED DIMENSION OF BODY (BUTTON AREA) ■ CARD LOCK METHOD

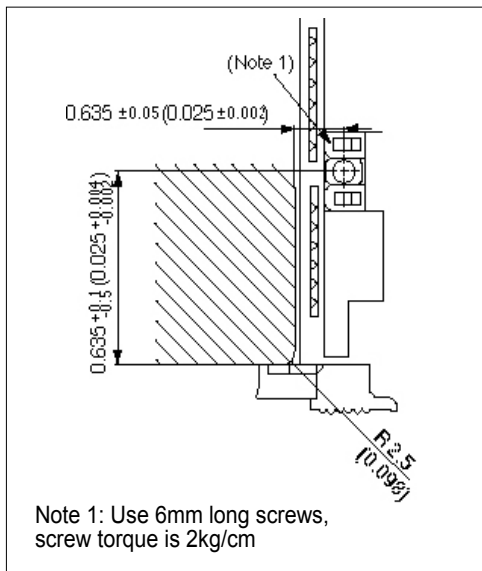

Note 1: Use 6mm long screws, screw torque is 2kg/cm

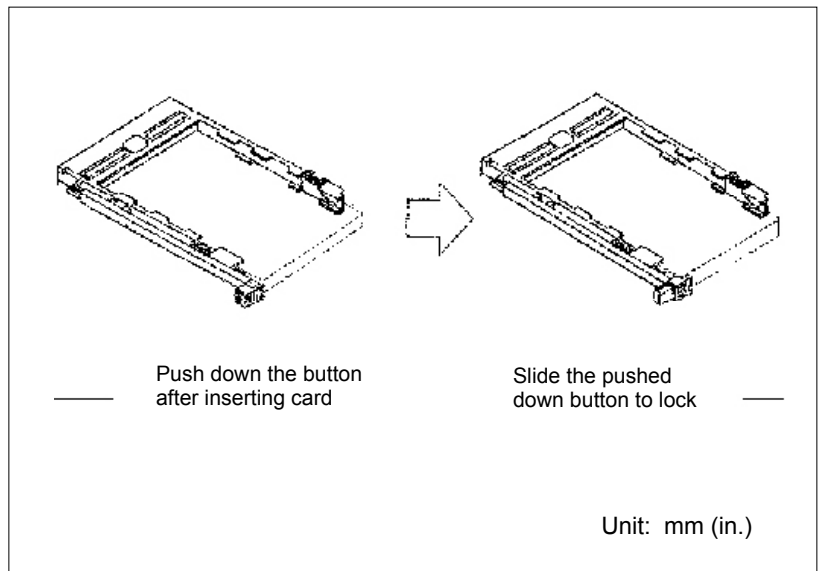

Unit: mm (in.)

560H Series Connector Conforming to Ver. 4

Fujitsu Components International Headquarter Offices

Japan

Fujitsu Component Limited
Gotanda-Chuo Building
3-5, Higashigotanda 2-chome, Shinagawa-ku
Tokyo 141, Japan
Tel: (81-3) 5449-7010
Fax: (81-3) 5449-2626
Email: promothq@ft.ed.fujitsu.com
Web: www.fcl.fujitsu.com

North and South America

Fujitsu Components America, Inc.
250 E. Caribbean Drive
Sunnyvale, CA 94089 U.S.A.
Tel: (1-408) 745-4900
Fax: (1-408) 745-4970
Email: components@us.fujitsu.com
Web: <http://us.fujitsu.com/components/>

Europe

Fujitsu Components Europe B.V.
Diamantlaan 25
2132 WV Hoofddorp
Netherlands
Tel: (31-23) 5560910
Fax: (31-23) 5560950
Email: info@fceu.fujitsu.com
Web: <http://www.fujitsu.com/emea/services/components/>

Asia Pacific

Fujitsu Components Asia Ltd.
102E Pasir Panjang Road
#04-01 Citilink Warehouse Complex
Singapore 118529
Tel: (65) 6375-8560
Fax: (65) 6273-3021
Email: fcal@fcal.fujitsu.com
Web: <http://www.fujitsu.com/sg/services/micro/components/>

©2008 Fujitsu Components America, Inc. All rights reserved. All trademarks or registered trademarks are the property of their respective owners.

Fujitsu Components America does not warrant that the content of datasheet is error free. In a continuing effort to improve our products Fujitsu Components America, Inc. reserves the right to change specifications/datasheets without prior notice. Rev. August 8, 2008.