

FEATURES

- Medium Power Output: $P_{1dB} = 16.0dBm$ (Typ.)@12.0GHz
- High Power Gain: $G_{1dB} = 8.0dB$ (Typ.)@12.0GHz
- Proven Reliability
- Cost Effective Hermetic Microstrip Package
- Tape and Reel Available

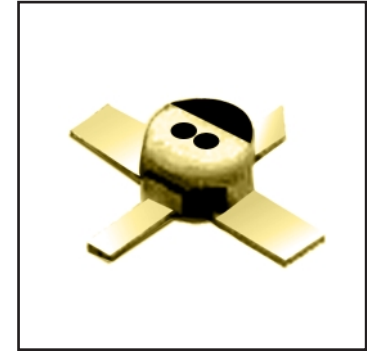

DESCRIPTION

The FSX017LG is a general purpose GaAs FET designed for medium power applications up to 12GHz. These devices have a wide dynamic range and are suitable for use in medium power, wide band, linear drive amplifiers.

Eudyna stringent Quality Assurance Program assures the highest reliability and consistent performance.

ABSOLUTE MAXIMUM RATING (Ambient Temperature $T_a=25^{\circ}C$)

Item	Symbol	Condition	Rating	Unit
Drain-Source Voltage	V_{DS}		8	V
Gate-Source Voltage	V_{GS}		-5	V
Total Power Dissipation	P_{tot}	Note	220	mW
Storage Temperature	T_{stg}		-65 to +175	$^{\circ}C$
Channel Temperature	T_{ch}		175	$^{\circ}C$

Note: Mounted on Al_2O_3 board (30 x 30 x 0.65mm)

For reliable operation of this FET:

1. The drain - source operating voltage (V_{DS}) should not exceed 4 volts.
2. The forward and reverse gate currents should not exceed 0.7 and -0.1 mA respectively with gate resistance of 2000 Ω .
3. The operating channel temperature (T_{ch}) should not exceed 145 $^{\circ}C$.

ELECTRICAL CHARACTERISTICS (Ambient Temperature $T_a=25^{\circ}C$)

Item	Symbol	Test Conditions	Limit			Unit
			Min.	Typ.	Max.	
Saturated Drain Current	I_{DSS}	$V_{DS} = 3V, V_{GS} = 0V$	35	55	75	mA
Transconductance	g_m	$V_{DS} = 3V, I_{DS} = 27mA$	-	50	-	mS
Pinch-off Voltage	V_p	$V_{DS} = 3V, I_{DS} = 2.7mA$	-0.7	-1.2	-1.7	V
Gate Source Breakdown Voltage	V_{GSO}	$I_{GS} = -2.7\mu A$	-5	-	-	V
Output Power at 1dB G.C.P.	P_{1dB}	$V_{DS} = 4V$ $I_{DS} = 30mA$ $f = 12GHz$	15.0	16.0	-	dBm
Power Gain at 1dB G.C.P.	G_{1dB}		7.0	8.0	-	dB
Thermal Resistance	R_{th}	Channel to Case	-	300	400	$^{\circ}C/W$

CASE STYLE: LG

G.C.P.: Gain Compression Point

Note: The RF parameters are measured on a lot basis by sample testing at an AQL = 0.1%, Level-II inspection. Any lot failure shall be 100% retested.

FSX017LG

General Purpose GaAs FET

POWER DERATING CURVE

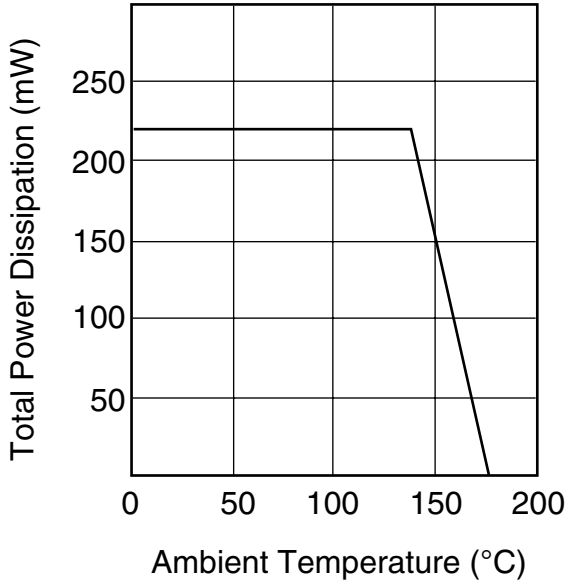

DRAIN CURRENT vs. DRAIN-SOURCE VOLTAGE

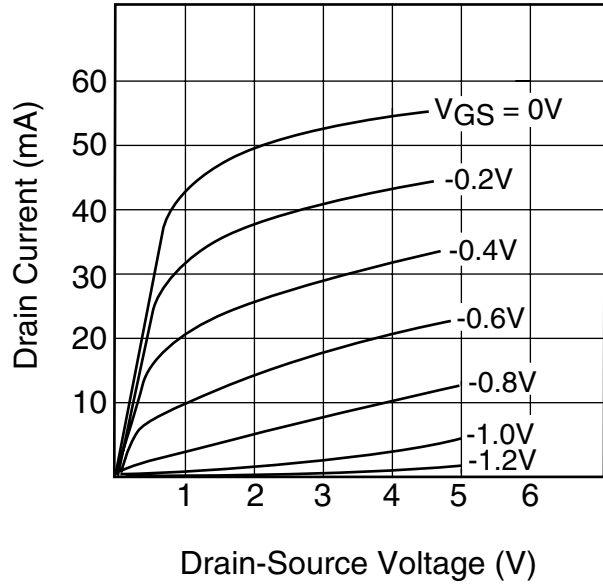

OUTPUT POWER vs. INPUT POWER

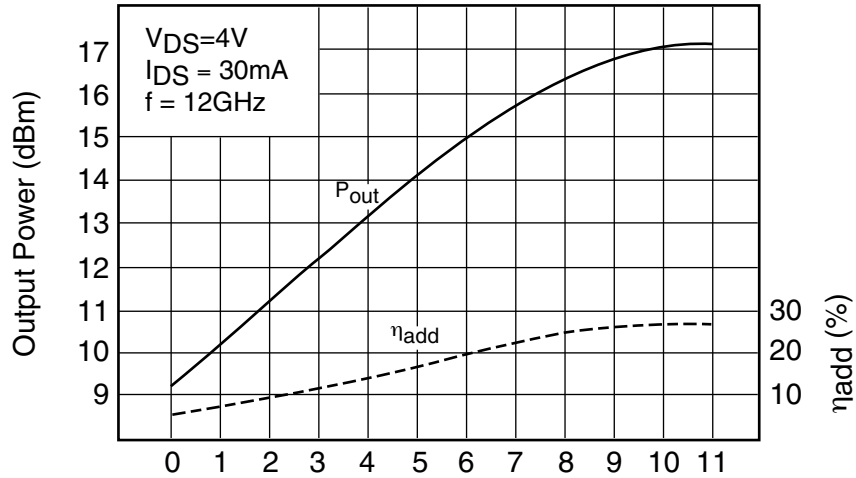

FSX017LG

General Purpose GaAs FET

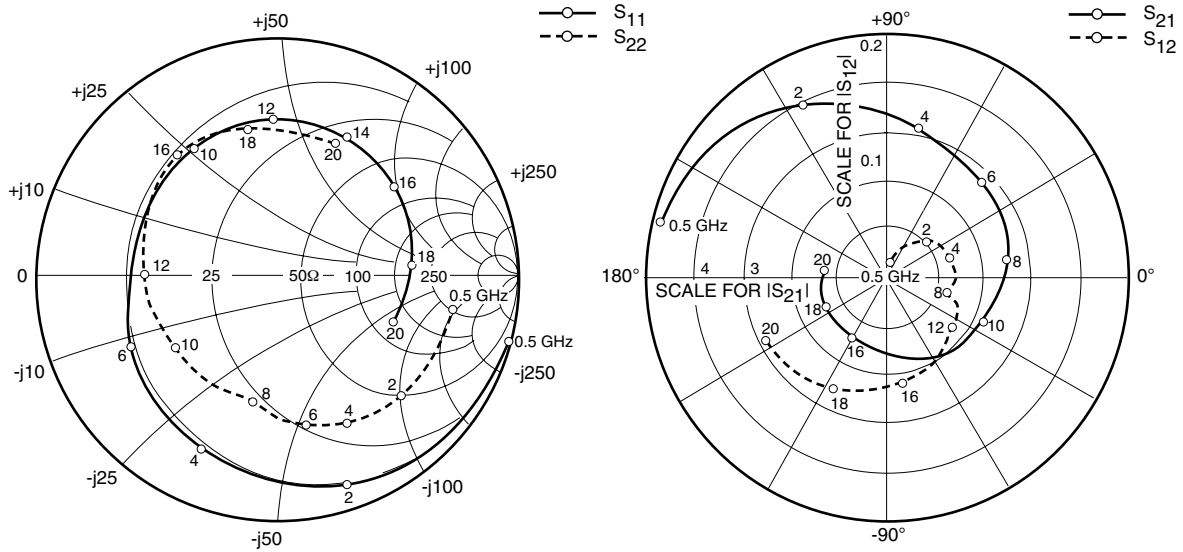

S-PARAMETERS

$V_{DS} = 4V, I_{DS} = 30mA$

FREQUENCY (MHZ)	S ₁₁		S ₂₁		S ₁₂		S ₂₂	
	MAG	ANG	MAG	ANG	MAG	ANG	MAG	ANG
500	.992	-15.5	4.814	165.8	.012	78.8	.735	-9.5
2000	.915	-58.9	4.244	127.5	.039	51.8	.709	-35.8
4000	.795	-104.8	3.300	86.9	.053	24.1	.670	-60.0
6000	.690	-144.0	2.839	54.1	.054	6.4	.632	-74.7
8000	.606	167.3	2.542	18.1	.052	-13.4	.533	-95.2
10000	.628	130.0	2.237	-16.3	.052	-16.5	.484	-133.0
12000	.655	98.8	1.924	-51.0	.067	-33.2	.544	-173.9
14000	.658	70.8	1.633	-82.5	.075	-51.9	.594	158.0
16000	.630	44.8	1.466	-113.5	.085	-75.4	.650	134.1
18000	.570	14.0	1.394	-147.7	.096	-107.7	.648	109.1
20000	.513	-18.3	1.296	172.6	.112	-151.6	.619	68.1

FSX017LG

General Purpose GaAs FET

Case Style "LG" Metal-Ceramic Hermetic Package

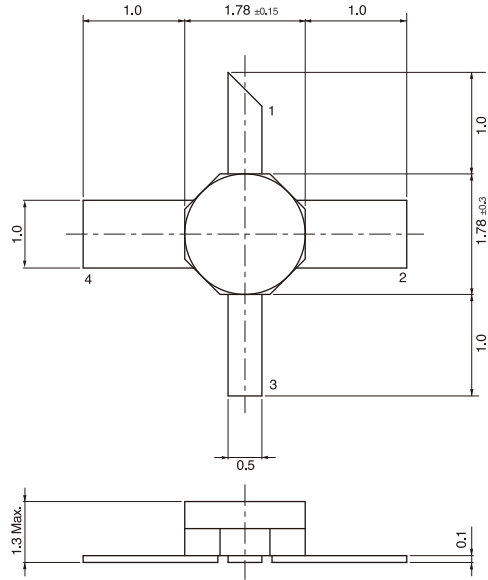

- 1. Gate
- 2. Source
- 3. Drain
- 4. Source

Unit: mm