

Customer Information Sheet

DRAWING No.: H8062-01, H8063-01 SHEET 2 OF 2 IF IN DOUBT - ASK (C) NOT TO SCALE THIRD ANGLE PROJECTION ALL DIMENSIONS IN mm

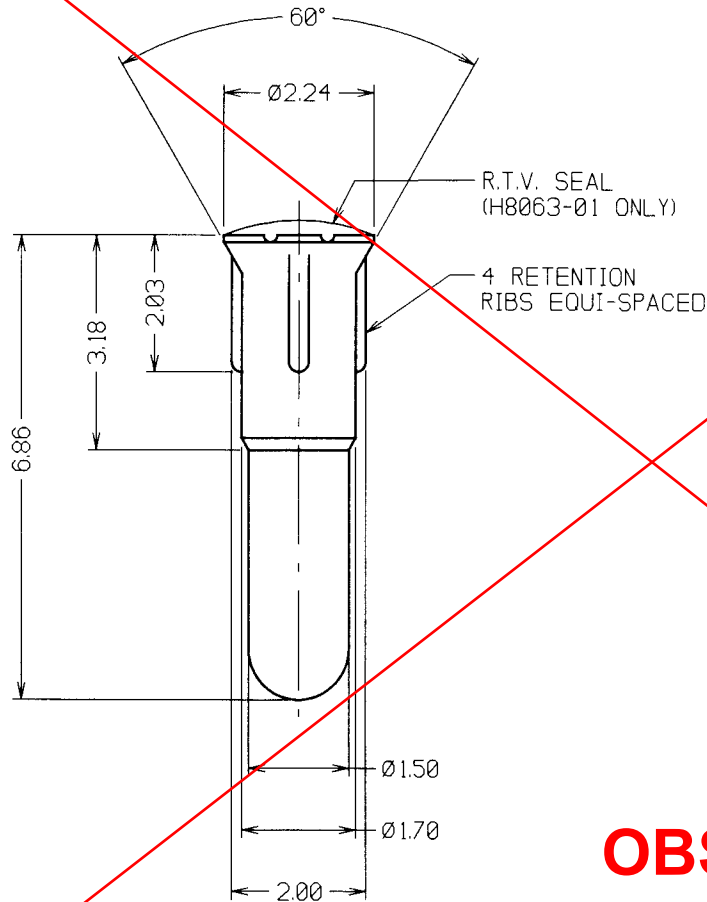

NOTES:

1. RECOMMENDED MOUNTING HOLE = 0.195-1.75mm.
RECOMMENDED SPACING = 3.18mm PITCH GRID.
RECOMMENDED LEAD LENGTH = 2.80-6.60mm.
RECOMMENDED PCB SIZE = 1.52-3.18mm.
SOCKET MAY STAND PROUD OF PCB BY 0.76mm MAX.
2. SOCKET WILL ACCEPT AND RETAIN PINS RANGING FROM 0.69 TO 0.84mm OR 0.64mm SQUARE.
3. RTV SEAL PREVENTS SOLDER ENTERING SOCKETS DURING REFLOW OPERATIONS.

SPECIFICATION:

MATERIAL:

SHELL - GILDING MATERIAL (95/5 COPPER/ZINC)
CONTACT - BERYLLIUM COPPER

FINISH:

SHELL - 25μ TIN
CONTACT - 0.63μ GOLD

ELECTRICAL:

CURRENT RATING - 2 AMPS

MECHANICAL:

INSERTION FORCE (0.084mm GAUGE) - 30N MAX
WITHDRAWAL FORCE (0.69mm GAUGE) - 0.15N MIN
ALSO TESTED UNDER VIBRATION, MECHANICAL AND THERMAL SHOCK CONDITIONS.

OBSOLETE

JAE	5	31.07.03	7495
NAME	ISS.	DATE	C/NOTE
APPROVED: <i>[Signature]</i>			
CHECKED: <i>[Signature]</i>			
DRAWN: P. D. COLLINS			
CUSTOMER REF.:			
ASSEMBLY DRG:			

HARWIN

HARWIN INC U.S.A. TEL: (812) 542 2546 FAX: (812) 542 2541	HARWIN PLC UK. TEL: 023 9237 0451 FAX: 023 9231 4590	HARWIN PTE SINGAPORE TEL: 65 6779 4909 FAX: 65 6779 3868
--	---	---

THIS DRAWING AND ANY INFORMATION OR DESCRIPTIVE MATTER SET OUT HEREON ARE CONFIDENTIAL AND COPYRIGHT PROPERTY OF THE HARWIN GROUP AND MUST NOT BE DISCLOSED, LOANED, COPIED OR USED FOR MANUFACTURING, TENDERING OR FOR ANY OTHER PURPOSE WITHOUT THEIR WRITTEN PERMISSION.

TOLERANCES
X. - ±1mm
X.X - ±0.25mm
X.XX - ±0.10mm
X.XXX - ±0.01mm
ANGLES - ±5°
UNLESS STATED

MATERIAL:
SEE ABOVE
FINISH: SEE ABOVE
S/AREA: mm²

TITLE:
SOCKET (0.64mm SQUARE PIN AND 0.69mm TO 0.84mm)
DRAWING NUMBER:
H8062-01, H8063-01
SHT 2 OF 2