

# HFD3023-002/XXX

## 5 Mbit Direct Coupled Receiver

---

### FEATURES

- Converts fiber optic input signals to TTL digital outputs
- Typical sensitivity 2  $\mu$ W peak (-27 dBm)
- Wide variety of cable options, operates with 50/125, 62.5/125, and 100/140  $\mu$ m cables
- Direct coupled receiver circuit
- Designed to operate with Honeywell 850 nm LEDs
- Single 5 V supply requirement
- Wave solderable
- Mounting options
  - SMA single hole
  - ST single hole
  - SMA PCB
  - ST PCB
  - SMA 4 hole

### DESCRIPTION

The HFD3023-002/XXX is a sensitive Direct Coupled (DC) optical receiver designed for use in short distance, 850 nm fiber optic systems. The receiver contains a monolithic IC, consisting of a photodiode, DC amplifier, and open collector Schottky output transistor. The output allows it to be directly interfaced with standard TTL circuits. The HFD3023-002/XXX receiver is comprised of a HFD3023 receiver component packaged in a fiber optic connector.

### APPLICATION

The HFD3023-002/XXX fiber optic receiver converts the optical signal in a point to point data communications fiber optic link to a TTL output. Its 0.006 in. photodiode with a 0.024 in. microlens (to enhance the optics) is mechanically centered within the fiber optic connector.

Electrical isolation is important in obtaining the maximum performance. A 0.1  $\mu$ F bypass capacitor must be connected between  $V_{CC}$  and ground. This minimizes power supply noise, increasing the signal quality. Shielding can also reduce coupled noise, through use of ground plane PCB, shielding around the device, and shielding around the leads.

The HFD3023-002/XXX is designed for a wide optical input range. The optical input dynamic range is guaranteed from the maximum sensitivity of 3.0  $\mu$ W to 100  $\mu$ W or greater than 15 dB.

# HFD3023-002/XXX

## 5 Mbit Direct Coupled Receiver

---

### APPLICATION (continued)

Optical power from the fiber strikes the photodiode and is converted to electrical current. This current couples to the DC amplifier, which drives an open collector transistor output. The output when connected to a pull up resistor can interface to TTL loads. The electrical signal is the inverse of the input light signal. When light strikes the photodiode, the output is a low logic level. When no light strikes the photodiode, the output is a high logic level.

Pulse Width Distortion (PWD) is an increase in the output pulse width (for high level optical input). The typical performance curves illustrate how PWD varies with optical power, temperature and frequency for the HFD3023-002/XXX. The amount of PWD that a given system can tolerate without an error due to a missing bit of information, is dependent upon system considerations. The output of the HFD3023-002/XXX will typically connect to the input of some form of a serial interface adaptor IC. The specifications for that IC govern the amount of PWD that can be tolerated in the system.

# HFD3023-002/XXX

## 5 Mbit Direct Coupled Receiver

### ELECTRO-OPTICAL CHARACTERISTICS

(V<sub>CC</sub> = 5.0 VDC, T<sub>C</sub> = 25°C unless otherwise stated)

PARAMETER	SYMBOL	MIN	TYP	MAX	UNITS	TEST CONDITIONS
Minimum Input Sensitivity	P <sub>IN</sub> (Peak)		2	3	μW	f = 2.5 MHz, 100/140 μm core fiber λ = 850 nm, Duty Cycle = 50% PWD ≤ 10%
Minimum Input Sensitivity						
Minimum Input Sensitivity						
			-27	-25.2		
High Level Logic Output Voltage	V <sub>OH</sub>	2.4	4.5		V	P <sub>IN</sub> ≤ 0.1 μW, R <sub>L</sub> = 560 Ω
Low Level Logic Output Voltage	V <sub>OL</sub>		0.25	0.5	V	P <sub>IN</sub> ≥ 3 μW, R <sub>L</sub> = 560 Ω
Power Supply Current	I <sub>CC</sub>		4.5	6.5	mA	P <sub>IN</sub> ≤ 0.1 μW
Power Supply Current			13	15		P <sub>IN</sub> ≥ 3 μW
Rise Time	t <sub>R</sub>		6	9	ns	P <sub>IN</sub> = 10 μW, V <sub>O</sub> = 0.5 to 2.4V
Fall Time	t <sub>F</sub>		6	9	ns	P <sub>IN</sub> = 10 μW, V <sub>O</sub> = 2.4 to 0.5 V
Pulse Width Distortion	PWD		5	10	%	f = 2.5MHz, Duty Cycle = 50%
			25	35		P <sub>IN</sub> = 3 μW peak P <sub>IN</sub> = 80 μW peak

### ABSOLUTE MAXIMUM RATINGS

(T<sub>case</sub> = 25°C unless otherwise noted)

Storage temperature	-40 to +100°C
Operating temperature	-40 to +100°C
Lead solder temperature	260°C for 10 s
Junction temperature	150°C
Supply voltage	+6.0 V

Stresses greater than those listed under "Absolute Maximum Ratings" may cause permanent damage to the device. This is a stress rating only and functional operation of the device at these or any other conditions above those indicated in the operational section of this specification is not implied. Exposure to absolute maximum rating conditions for extended periods of time may affect reliability.

### RECOMMENDED OPERATING CONDITIONS

Operating temperature	-40 to +85°C
Supply voltage	+4.5 to +5.5 V
Optical input power	3.0 to 100 μW
Optical signal pulse width	> 100 ns
Optical signal edges (10 to 90%)	< 20 ns

# HFD3023-002/XXX

## 5 Mbit Direct Coupled Receiver

### ORDER GUIDE

Description	Catalog Listing
Fiber Optic Direct Coupled Receiver	HFD3023-002/XXX

### MOUNTING OPTIONS

Substitute XXX with one of the following 3 letter combinations

SMA single hole	- AAA
ST single hole	- BAA
SMA PCB	- ABA
ST PCB	- BBA
SMA 4 hole	- ADA

Dimensions on page 441

### CAUTION

The inherent design of this component causes it to be sensitive to electrostatic discharge (ESD). To prevent ESD-induced damage and/or degradation to equipment, take normal ESD precautions when handling this product.



### BLOCK DIAGRAM

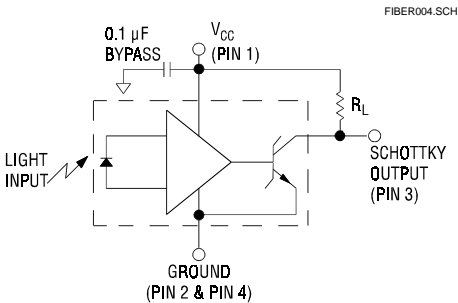

### FIBER INTERFACE

Honeywell detectors are designed to interface with multimode fibers with sizes (core/cladding diameters) ranging from 50/125 to 200/230 microns. Honeywell performs final tests using 100/140 micron core fiber. The fiber chosen by the end user will depend upon a number of application issues (distance, link budget, cable attenuation, splice attenuation, and safety margin). The 50/125 and 62.5/125 micron fibers have the advantages of high bandwidth and low cost, making them ideal for higher bandwidth installations. The use of 100/140 and 200/230 micron core fibers results in greater power being coupled by the transmitter, making it easier to splice or connect in bulkhead areas. Optical cables can be purchased from a number of sources.

### SWITCHING WAVEFORM

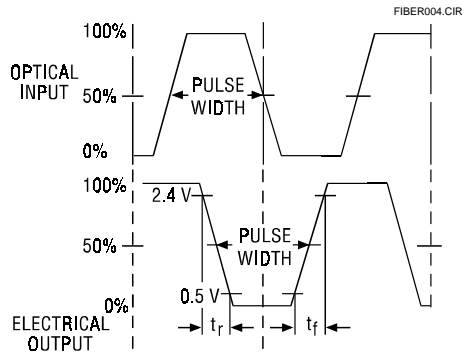

# HFD3023-002/XXX

## 5 Mbit Direct Coupled Receiver

Fig. 1 Pulse Width Distortion vs Optical Input Power

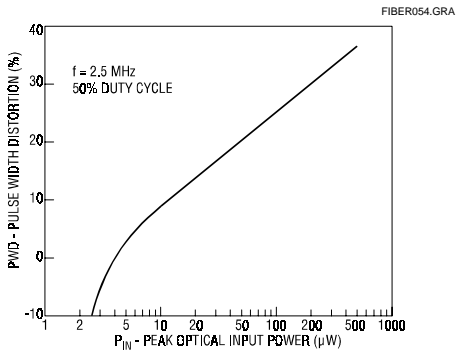

Fig. 2 Pulse Width Distortion vs Temperature

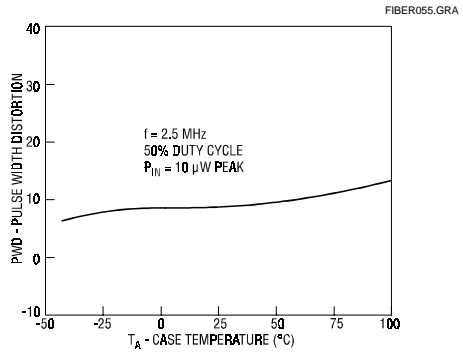

Fig. 3 Pulse Width Distortion vs Frequency

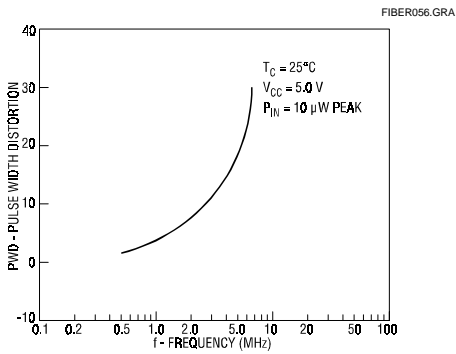
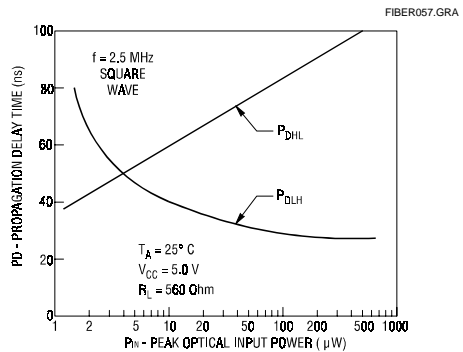

Fig. 4 Propagation Delay Time vs Peak Optical Input Power



# European Connectorized Receivers

Honeywell receiver components are available in the following connector styles. Each style has a three-digit reference used in the order guides.

## SMA SINGLE HOLE MOUNTING (REF.: AAA)

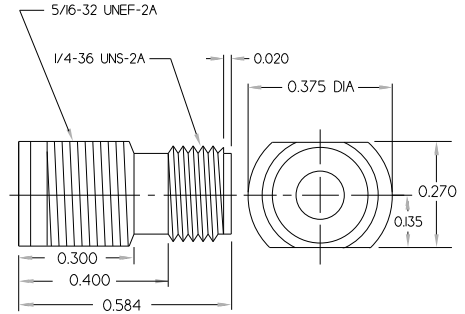

## ST SINGLE HOLE MOUNTING (REF.: BAA)

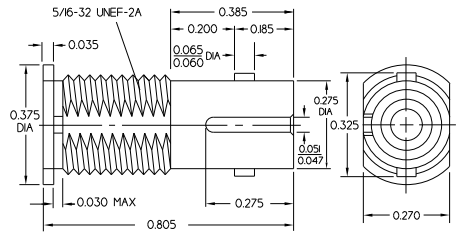

## SMA PCB MOUNTING (REF.: ABA)

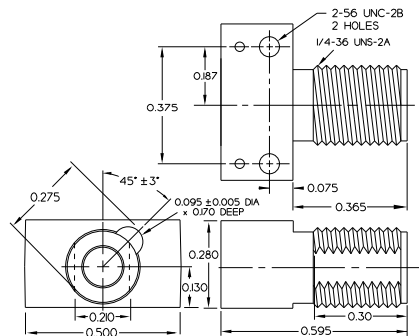
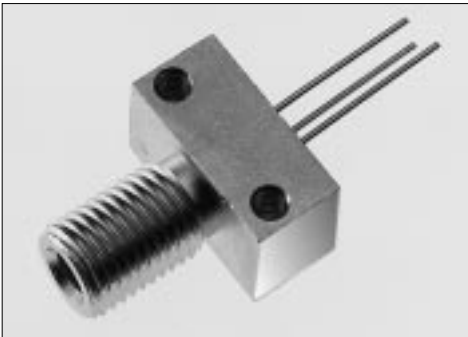

Honeywell Optoelectronics reserves the right to make changes at any time in order to improve design and supply the best products possible.

**Honeywell**

# European Connectorized Receivers

## ST PCB MOUNTING (REF.: BBA)

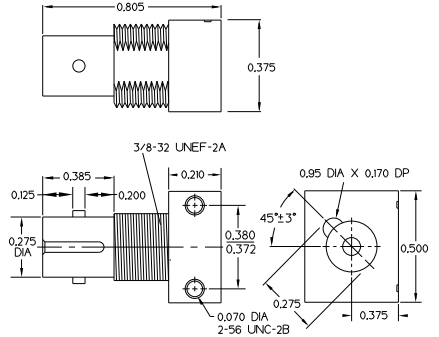

## SMA 4 HOLE MOUNTING (REF.: ADA)

