



### Features

- ◆ High speed (equal access and cycle time)
  - Military: 25/35/45/55/70/85ns (max.)
- ◆ Low power consumption
- ◆ Battery backup operation—2V data retention (L version only)
- ◆ JEDEC standard high-density 22-pin ceramic DIP packaging
- ◆ Produced with advanced CMOS high-performance technology
- ◆ Separate data input and output
- ◆ Input and output directly TTL-compatible
- ◆ Military product compliant to MIL-STD-883, Class B

### Description

The IDT7187 is a 65,536-bit high-speed static RAM organized as 64K x 1. It is fabricated using IDT's high-performance, high-reliability CMOS technology. Access times as fast as 25ns are available.

Both the standard (S) and low-power (L) versions of the IDT7187 provide two standby modes—ISB and ISB1. ISB provides low-power operation; ISB1 provides ultra-low-power operation. The low-power (L) version also provides the capability for data retention using battery backup. When using a 2V battery, the circuit typically consumes only 30µW.

Ease of system design is achieved by the IDT7187 with full asynchronous operation, along with matching access and cycle times. The device is packaged in an industry standard 22-pin, 300 mil ceramic DIP.

Military grade product is manufactured in compliance with the latest revision of MIL-STD-883, Class B, making it ideally suited to military temperature applications demanding the highest level of performance and reliability.

### Functional Block Diagram

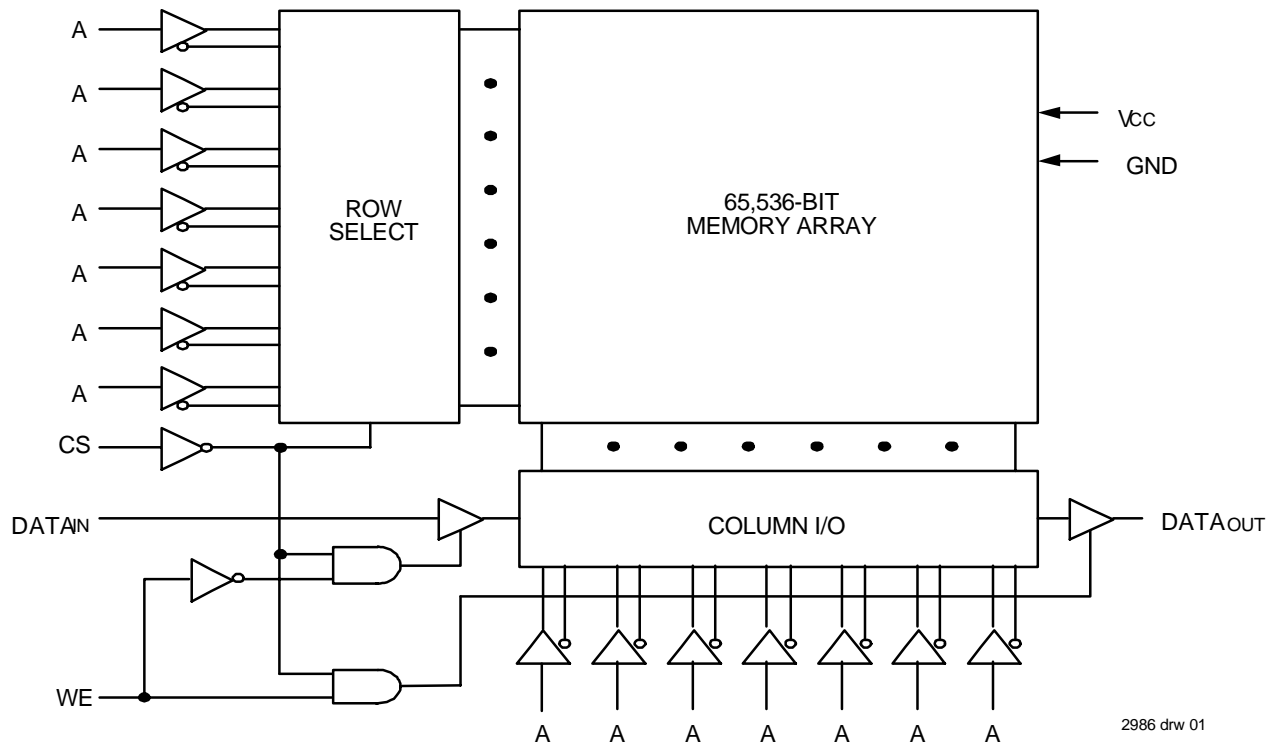

2986 drw 01

## Pin Configuration

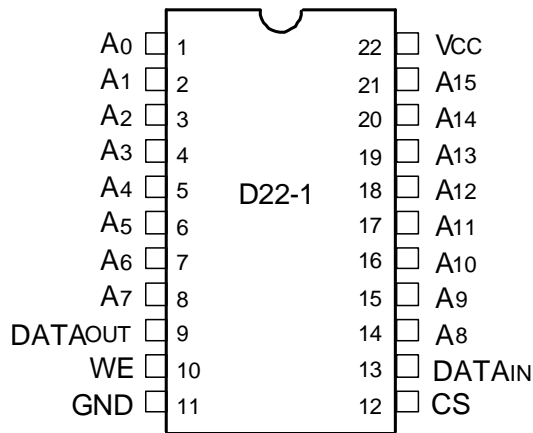

2986 drw 02

## DIP Top View

## Pin Descriptions

Name	Description
A <sub>0</sub> - A <sub>15</sub>	Address Inputs
$\overline{CS}$	Chip Select
$\overline{WE}$	Write Enable
V <sub>CC</sub>	Power
DATA <sub>IN</sub>	Data Input
DATA <sub>OUT</sub>	Data Output
GND	Ground

2986 tbl 01

## Truth Table<sup>(1)</sup>

Mode	$\overline{CS}$	$\overline{WE}$	Output	Power
Standby	H	X	High-Z	Standby
Read	L	H	Dout	Active
Write	L	L	High-Z	Active

2986 tbl 02

**NOTE:**

1. H = V<sub>IH</sub>, L = V<sub>IL</sub>, X = don't care.

## Absolute Maximum Ratings<sup>(1)</sup>

Symbol	Rating	Value	Unit
V <sub>TERM</sub>	Terminal Voltage with Respect to GND	-0.5 to +7.0	V
T <sub>A</sub>	Operating Temperature	-55 to +125	°C
T <sub>BIAS</sub>	Temperature Under Bias	-65 to +135	°C
T <sub>STG</sub>	Storage Temperature	-65 to +150	°C
P <sub>T</sub>	Power Dissipation	1.0	W
I <sub>OUT</sub>	DC Output Current	50	mA

2986 tbl 03

**NOTE:**

1. Stresses greater than those listed under ABSOLUTE MAXIMUM RATINGS may cause permanent damage to the device. This is a stress rating only and functional operation of the device at these or any other conditions above those indicated in the operational sections of this specification is not implied. Exposure to absolute maximum rating conditions for extended periods may affect reliability.

## Capacitance (T<sub>A</sub> = +25°C, f = 1.0MHz)

Symbol	Parameter <sup>(1)</sup>	Conditions	Max.	Unit
C <sub>IN</sub>	Input Capacitance	V <sub>IN</sub> = 0V	8	pF
C <sub>OUT</sub>	Output Capacitance	V <sub>OUT</sub> = 0V	8	pF

2986 tbl 04

**NOTE:**

1. This parameter is determined by device characterization, but is not production tested.

## Recommended DC Operations Conditions

Symbol	Parameter	Min.	Typ.	Max.	Unit
V <sub>CC</sub>	Supply Voltage	4.5	5.0	5.5	V
GND	Ground	0	0	0	V
V <sub>IH</sub>	Input High Voltage	2.2	—	6.0	V
V <sub>IL</sub>	Input Low Voltage	-0.5 <sup>(1)</sup>	—	0.8	V

2986 tbl 05

**NOTE:**

1. V<sub>IL</sub> (min.) = -3.0V for pulse width less than 20ns, once per cycle.

## Recommended Operating Temperature and Supply Voltage

Grade	Temperature	GND	V <sub>CC</sub>
Military	-55°C to +125°C	0V	5V ± 10%

2986 tbl 06

## DC Electrical Characteristics (V<sub>CC</sub> = 5.0V ± 10%)

Symbol	Parameter	Test Conditions	IDT7187S		IDT7187L		Unit
			Min.	Max.	Min.	Max.	
I <sub>LI</sub>	Input Leakage Current	V <sub>CC</sub> = Max., V <sub>IN</sub> = GND to V <sub>CC</sub>	—	10	—	5	μA
I <sub>LO</sub>	Output Leakage Current	V <sub>CC</sub> = Max., $\overline{CS} = V_{IH}$ , V <sub>OUT</sub> = GND to V <sub>CC</sub>	—	10	—	5	μA
V <sub>OL</sub>	Output Low Voltage	I <sub>OL</sub> = 10mA, V <sub>CC</sub> = Min.	—	0.5	—	0.5	V
		I <sub>OL</sub> = 8mA, V <sub>CC</sub> = Min.	—	0.4	—	0.4	
V <sub>OH</sub>	Output High Voltage	I <sub>OH</sub> = -4mA, V <sub>CC</sub> = Min.	2.4	—	2.4	—	V

2986 tbl 07

## DC Electrical Characteristics<sup>(1)</sup> (V<sub>CC</sub> = 5V ± 10%, V<sub>LC</sub> = 0.2V, V<sub>HC</sub> = V<sub>CC</sub> - 0.2V)

Symbol	Parameter	Power	7187S25	7187S35	7187S45	7187S55	7187S70	7187S85	Unit
			7187L25	7187L35	7187L45	7187L55	7187L70	7187L85	
I <sub>CC1</sub>	Operating Power Supply Current CS = V <sub>IL</sub> , Outputs Open V <sub>CC</sub> = Max., f = 0 <sup>(2)</sup>	S	105	105	105	105	105	105	mA
		L	85	85	85	85	85	85	
I <sub>CC2</sub>	Dynamic Operating Current CS = V <sub>IL</sub> , Outputs Open V <sub>CC</sub> = Max., f = f <sub>MAX</sub> <sup>(2)</sup>	S	130	120	120	120	120	120	mA
		L	110	100	95	90	90	90	
I <sub>SB</sub>	Standby Power Supply Current (TTL Level) CS ≥ V <sub>IH</sub> , Outputs Open V <sub>CC</sub> = Max., f = f <sub>MAX</sub> <sup>(2)</sup>	S	55	50	50	50	50	50	mA
		L	50	40	35	30	28	28	
I <sub>SB1</sub>	Full Standby Power Supply Current (CMOS Level) CS ≥ V <sub>HC</sub> , V <sub>CC</sub> = Max., V <sub>IN</sub> ≤ V <sub>LC</sub> or V <sub>IN</sub> ≥ V <sub>HC</sub> , f = 0 <sup>(2)</sup>	S	20	20	20	20	20	20	mA
		L	1.5	1.5	1.5	1.5	1.5	1.5	

2986 tbl 08

### NOTES:

- All values are maximum guaranteed values.
- At f = f<sub>MAX</sub> address and data inputs are cycling at the maximum frequency of read cycles of 1/trc. f = 0 means no input lines change.

### Data Retention Characteristics (L Version Only) ( $V_{HC} = V_{CC} - 0.2V$ , $V_{LC} = 0.2V$ )

Symbol	Parameter	Test Condition	Min.	Typ. <sup>(1)</sup> V <sub>CC</sub> @		Max. V <sub>CC</sub> @		Unit
				2.0V	3.0V	2.0V	3.0V	
V <sub>DR</sub>	V <sub>CC</sub> for Data Retention	—	2.0	—	—	—	—	V
I <sub>CDR</sub>	Data Retention Current	$\overline{CS} \geq V_{HC}$ $V_{IN} \geq V_{HC}$ or $\leq V_{LC}$	—	10	15	600	900	μA
t <sub>CDR</sub> <sup>(3)</sup>	Chip Deselect to Data Retention Tim		0	—	—	—	—	ns
t <sub>R</sub> <sup>(3)</sup>	Operation Recovery Time		t <sub>RC</sub> <sup>(2)</sup>	—	—	—	—	ns
I <sub>IL</sub> <sup>(3)</sup>	Input Leakage Current		—	—	—	2	2	μA

2986 tbl 09

**NOTES:**

- TA = +25°C.
- t<sub>RC</sub> = Read Cycle Time.
- This parameter is guaranteed, but not tested.

### Low V<sub>CC</sub> Data Retention Waveform

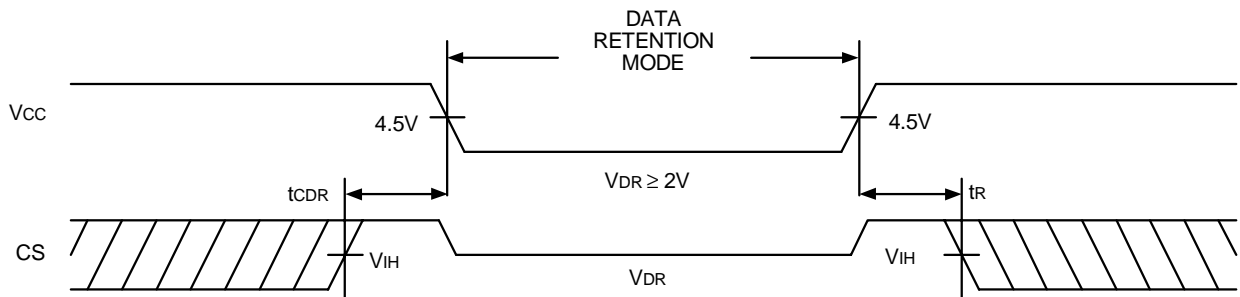

2986 drw 04

### AC Test Conditions

Input Pulse Levels	GND to 3.0V
Input Rise/Fall Times	5ns
Input Timing Reference Levels	1.5V
Output Reference Levels	1.5V
AC Test Load	See Figures 1 and 2

2986 tbl 10

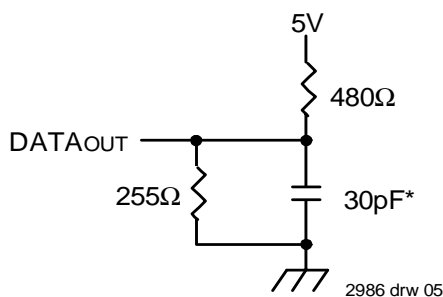

2986 drw 05

Figure 1. AC Test Load

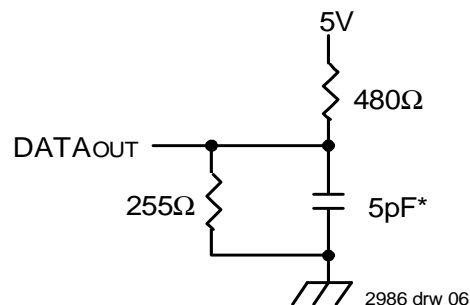

2986 drw 06

Figure 2. AC Test Load  
(for t<sub>HZ</sub>, t<sub>LZ</sub>, t<sub>wz</sub> and t<sub>ow</sub>)

\*Includes scope and jig capacitances

### AC Electrical Characteristics (Vcc = 5.0V ± 10%)

Symbol	Parameter	7187S25 7187L25		7187S35/45 7187L35/45		7187S55 7187L55		7187S70 7187L70		7187S85 7187L85		Unit
		Min.	Max.	Min.	Max.	Min.	Max.	Min.	Max.	Min.	Max.	
<b>Read Cycle</b>												
t <sub>RC</sub>	Read Cycle Time	25	—	35/45	—	55	—	70	—	85	—	ns
t <sub>AA</sub>	Address Access Time	—	25	—	35/45	—	55	—	70	—	85	ns
t <sub>ACS</sub>	Chip Select Access Time	—	25	—	35/45	—	55	—	70	—	85	ns
t <sub>OH</sub>	Output Hold from Address Change	5	—	5	—	5	—	5	—	5	—	ns
t <sub>LZ</sub> <sup>(1)</sup>	Output Select to Output in Low-Z	5	—	5	—	5	—	5	—	5	—	ns
t <sub>HZ</sub> <sup>(1)</sup>	Chip Deselect to Output in High-Z	—	12	—	17/20	—	30	—	30	—	40	ns
t <sub>PU</sub> <sup>(1)</sup>	Chip Select to Power Up Time	0	—	0	—	0	—	0	—	0	—	ns
t <sub>PD</sub> <sup>(1)</sup>	Chip Deselect to Power Down Time	—	20	—	30/35	—	35	—	35	—	40	ns

2986 tbl 11

**NOTE:**

1. This parameter guaranteed but not tested.

### Timing Waveform of Read Cycle No. 1<sup>(1,2)</sup>

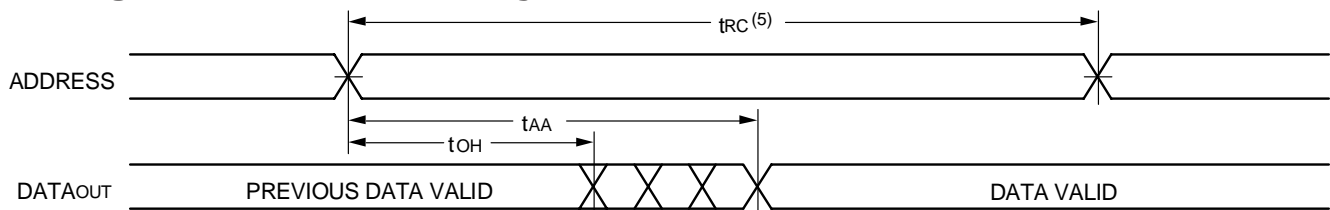

2986 drw 07

### Timing Waveform of Read Cycle No. 2<sup>(1,3)</sup>

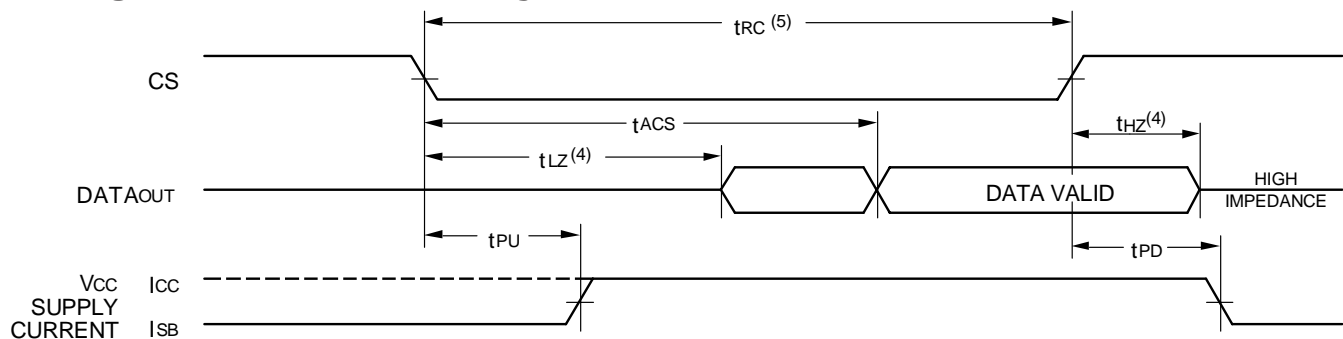

2986 drw 08

**NOTES:**

1.  $\overline{WE}$  is HIGH for Read cycle.
2.  $\overline{CS}$  is LOW for Read cycle.
3. Address valid prior to or coincident with  $\overline{CS}$  transition LOW.
4. Transition is measured  $\pm 200mV$  from steady state voltage with specified loading in Figure 2.
5. All Read cycle timings are referenced from the last valid address to the first transitioning address.

### AC Electrical Characteristics (Vcc = 5.0V ± 10%)

Symbol	Parameter	7187S25 7187L25		7187S35/45 7187L35/45		7187S55 7187L55		7187S70 7187L70		7187S85 7187L85		Unit
		Min.	Max.	Min.	Max.	Min.	Max.	Min.	Max.	Min.	Max.	
<b>Write Cycle</b>												
t <sub>wc</sub>	Write Cycle Time	25	—	35/45	—	55	—	70	—	85	—	ns
t <sub>cw</sub>	Chip Select to End-of-Write	20	—	25/40	—	50	—	55	—	65	—	ns
t <sub>aw</sub>	Address Valid to End-of-Write	20	—	25/40	—	50	—	55	—	65	—	ns
t <sub>as</sub>	Address Set-up Time	0	—	0	—	0	—	0	—	0	—	ns
t <sub>wp</sub>	Write Pulse Width	20	—	20/25	—	35	—	40	—	45	—	ns
t <sub>wr</sub>	Write Recovery Time	0	—	0	—	0	—	0	—	0	—	ns
t <sub>dw</sub>	Data Valid to End-of-Write	15	—	15/25	—	25	—	30	—	35	—	ns
t <sub>dh</sub>	Data Hold Time	5	—	5	—	5	—	5	—	5	—	ns
t <sub>wz</sub> <sup>(1)</sup>	Write Enable to Output in High-Z	—	12	—	15/30	—	30	—	30	—	40	ns
t <sub>ow</sub> <sup>(1)</sup>	Output Active from End-of-Write	0	—	0	—	0	—	0	—	0	—	ns

2986 tbl 12

**NOTE:**

1. This parameter guaranteed but not tested.

### Timing Waveform of Write Cycle No. 1 ( $\overline{WE}$ Controlled Timing)<sup>(1,2,3,4)</sup>

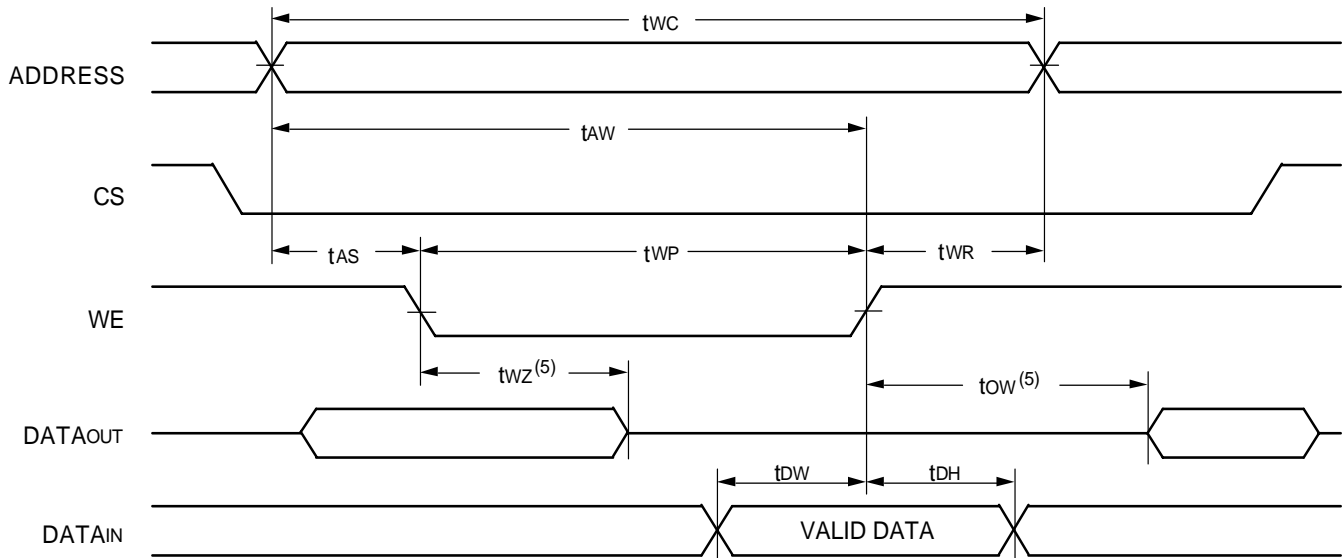

2986 drw 09

**NOTES:**

1.  $\overline{WE}$  or  $\overline{CS}$  must be HIGH during all address transitions.
2. A write occurs during the overlap (t<sub>wp</sub>) of a LOW  $\overline{CS}$  and a LOW  $\overline{WE}$ .
3. t<sub>wr</sub> is measured from the earlier of  $\overline{CS}$  or  $\overline{WE}$  going HIGH to the end of the write cycle.
4. If the  $\overline{CS}$  LOW transition occurs simultaneously with or after the  $\overline{WE}$  LOW transition, the outputs remain in the high-impedance state.
5. Transition is measured ±200mV from steady state with a 5pF load (including scope and jig).

### Timing Waveform of Write Cycle No. 2 ( $\overline{CS}$ Controlled Timing)<sup>(1,2,4)</sup>

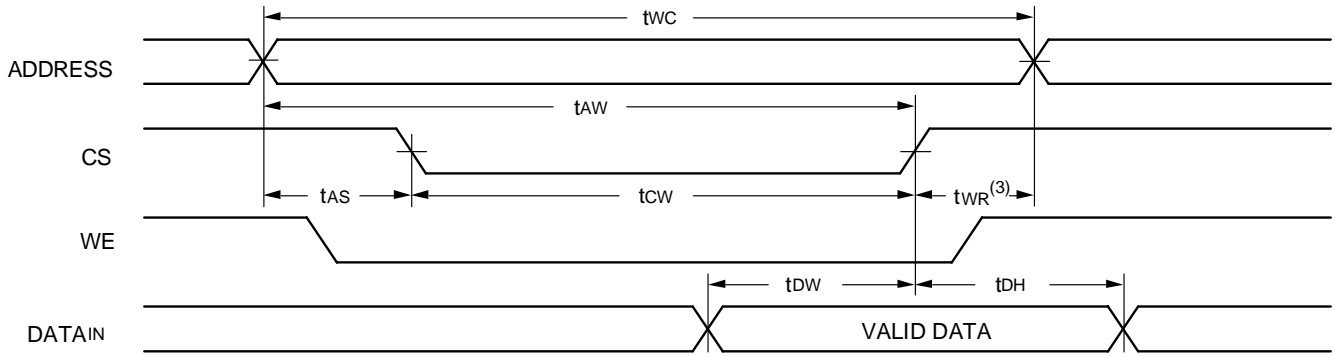

2986 drw 10

**NOTES:**

1.  $\overline{WE}$  or  $\overline{CS}$  must be HIGH during all address transitions.
2. A write occurs during the overlap ( $t_{WP}$ ) of a LOW  $\overline{CS}$  and a LOW  $\overline{WE}$ .
3.  $t_{WR}$  is measured from the earlier of  $\overline{CS}$  or  $\overline{WE}$  going HIGH to the end of the write cycle.
4. If the  $\overline{CS}$  LOW transition occurs simultaneously with or after the  $\overline{WE}$  LOW transition, the outputs remain in the high-impedance state.
5. Transition is measured  $\pm 200\text{mV}$  from steady state with a 5pF load (including scope and jig).

### Ordering Information

IDT7187	X	XX	X	X	
Device Type	Power	Speed	Package	Process/ Temperature Range	
				B	Military ( $-55^{\circ}\text{C}$ to $+125^{\circ}\text{C}$ ) Compliant to MIL-STD-883, Class B
				D	300 mil Ceramic DIP (D22-1)
				25 35 45 55 70 85	} Speed in nanoseconds
				S L	

2986 drw 11

## Datasheet Document History

11/xx/99		Updated to new format
	Pp. 1, 2, 8	Revised package offerings
	Pp. 3, 4	Removed commercial temperature data
	Pg. 8	Added Datasheet Document History
08/09/00		Not recommended for new designs
02/01/01		Removed "Not recommended for new designs"



**CORPORATE HEADQUARTERS**  
6024 Silver Creek Valley Road  
San Jose, CA 95138

**for SALES:**  
800-345-7015 or  
408-284-8200  
fax: 408-284-2775  
[www.idt.com](http://www.idt.com)

**for Tech Support:**  
[ipchelp@idt.com](mailto:ipchelp@idt.com)  
800-345-7015

The IDT logo is a registered trademark of Integrated Device Technology, Inc.