

LM111/LM211/LM311 Voltage Comparator

1.0 General Description

The LM111, LM211 and LM311 are voltage comparators that have input currents nearly a thousand times lower than devices like the LM106 or LM710. They are also designed to operate over a wider range of supply voltages: from standard $\pm 15V$ op amp supplies down to the single 5V supply used for IC logic. Their output is compatible with RTL, DTL and TTL as well as MOS circuits. Further, they can drive lamps or relays, switching voltages up to 50V at currents as high as 50 mA.

Both the inputs and the outputs of the LM111, LM211 or the LM311 can be isolated from system ground, and the output can drive loads referred to ground, the positive supply or the negative supply. Offset balancing and strobe capability are provided and outputs can be wire OR'ed. Although slower than the LM106 and LM710 (200 ns response time vs 40 ns)

the devices are also much less prone to spurious oscillations. The LM111 has the same pin configuration as the LM106 and LM710.

The LM211 is identical to the LM111, except that its performance is specified over a $-25^{\circ}C$ to $+85^{\circ}C$ temperature range instead of $-55^{\circ}C$ to $+125^{\circ}C$. The LM311 has a temperature range of $0^{\circ}C$ to $+70^{\circ}C$.

2.0 Features

- Operates from single 5V supply
- Input current: 150 nA max. over temperature
- Offset current: 20 nA max. over temperature
- Differential input voltage range: $\pm 30V$
- Power consumption: 135 mW at $\pm 15V$

3.0 Typical Applications (Note 3)

Offset Balancing

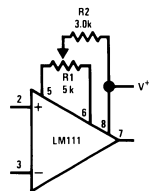

DS005704-36

Strobing

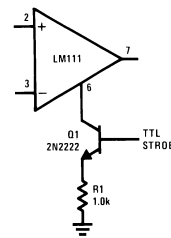

DS005704-37

Note: Do Not Ground Strobe Pin. Output is turned off when current is pulled from Strobe Pin.

Increasing Input Stage Current (Note 1)

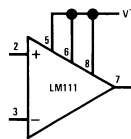

DS005704-38

Note 1: Increases typical common mode slew from $7.0V/\mu s$ to $18V/\mu s$.

Detector for Magnetic Transducer

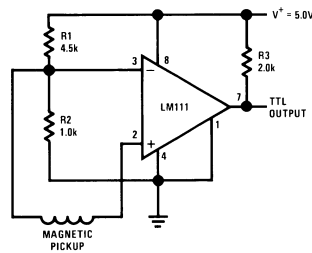

DS005704-39

3.0 Typical Applications (Note 3) (Continued)

Digital Transmission Isolator

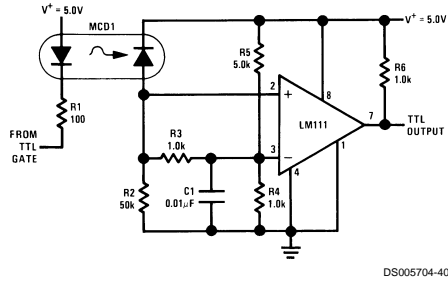

DS005704-40

Relay Driver with Strobe

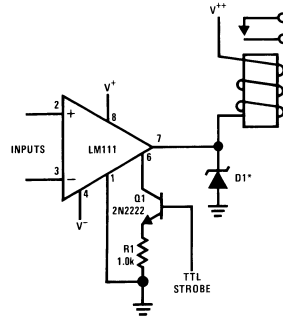

DS005704-41

*Absorbs inductive kickback of relay and protects IC from severe voltage transients on V⁺⁺ line.

Note: Do Not Ground Strobe Pin.

Strobing off Both Input and Output Stages (Note 2)

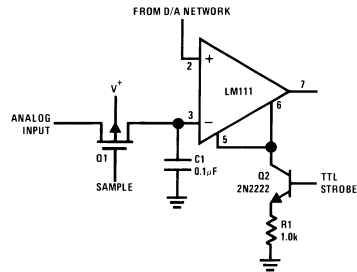

DS005704-42

Note: Do Not Ground Strobe Pin.

Note 2: Typical input current is 50 pA with inputs strobed off.

Note 3: Pin connections shown on schematic diagram and typical applications are for H08 metal can package.

4.0 Absolute Maximum Ratings for the LM111/LM211 (Note 10)

If Military/Aerospace specified devices are required, please contact the National Semiconductor Sales Office/Distributors for availability and specifications.

Total Supply Voltage (V_{84})	36V
Output to Negative Supply Voltage (V_{74})	50V
Ground to Negative Supply Voltage (V_{14})	30V
Differential Input Voltage	$\pm 30V$
Input Voltage (Note 4)	$\pm 15V$
Output Short Circuit Duration	10 sec

Operating Temperature Range

LM111	-55°C to 125°C
LM211	-25°C to 85°C

Lead Temperature (Soldering, 10 sec)

260°C

Voltage at Strobe Pin

$V^+ - 5V$

Soldering Information

Dual-In-Line Package	
Soldering (10 seconds)	260°C
Small Outline Package	
Vapor Phase (60 seconds)	215°C
Infrared (15 seconds)	220°C

See AN-450 "Surface Mounting Methods and Their Effect on Product Reliability" for other methods of soldering surface mount devices.

ESD Rating (Note 11) 300V

Electrical Characteristics (Note 6)

for the LM111 and LM211

Parameter	Conditions	Min	Typ	Max	Units
Input Offset Voltage (Note 7)	$T_A = 25^\circ C$, $R_S \leq 50k$		0.7	3.0	mV
Input Offset Current	$T_A = 25^\circ C$		4.0	10	nA
Input Bias Current	$T_A = 25^\circ C$		60	100	nA
Voltage Gain	$T_A = 25^\circ C$	40	200		V/mV
Response Time (Note 8)	$T_A = 25^\circ C$		200		ns
Saturation Voltage	$V_{IN} \leq -5$ mV, $I_{OUT} = 50$ mA $T_A = 25^\circ C$		0.75	1.5	V
Strobe ON Current (Note 9)	$T_A = 25^\circ C$		2.0	5.0	mA
Output Leakage Current	$V_{IN} \geq 5$ mV, $V_{OUT} = 35V$ $T_A = 25^\circ C$, $I_{STROBE} = 3$ mA		0.2	10	nA
Input Offset Voltage (Note 7)	$R_S \leq 50$ k			4.0	mV
Input Offset Current (Note 7)				20	nA
Input Bias Current				150	nA
Input Voltage Range	$V^+ = 15V$, $V^- = -15V$, Pin 7 Pull-Up May Go To 5V	-14.5	13.8, -14.7	13.0	V
Saturation Voltage	$V^+ \geq 4.5V$, $V^- = 0$ $V_{IN} \leq -6$ mV, $I_{OUT} \leq 8$ mA		0.23	0.4	V
Output Leakage Current	$V_{IN} \geq 5$ mV, $V_{OUT} = 35V$		0.1	0.5	μA
Positive Supply Current	$T_A = 25^\circ C$		5.1	6.0	mA
Negative Supply Current	$T_A = 25^\circ C$		4.1	5.0	mA

Note 4: This rating applies for $\pm 15V$ supplies. The positive input voltage limit is 30V above the negative supply. The negative input voltage limit is equal to the negative supply voltage or 30V below the positive supply, whichever is less.

Note 5: The maximum junction temperature of the LM111 is 150°C, while that of the LM211 is 110°C. For operating at elevated temperatures, devices in the H08 package must be derated based on a thermal resistance of 165°C/W, junction to ambient, or 20°C/W, junction to case. The thermal resistance of the dual-in-line package is 110°C/W, junction to ambient.

Note 6: These specifications apply for $V_S = \pm 15V$ and Ground pin at ground, and $-55^\circ C \leq T_A \leq +125^\circ C$, unless otherwise stated. With the LM211, however, all temperature specifications are limited to $-25^\circ C \leq T_A \leq +85^\circ C$. The offset voltage, offset current and bias current specifications apply for any supply voltage from a single 5V supply up to $\pm 15V$ supplies.

Note 7: The offset voltages and offset currents given are the maximum values required to drive the output within a volt of either supply with a 1 mA load. Thus, these parameters define an error band and take into account the worst-case effects of voltage gain and R_S .

Note 8: The response time specified (see definitions) is for a 100 mV input step with 5 mV overdrive.

Note 9: This specification gives the range of current which must be drawn from the strobe pin to ensure the output is properly disabled. Do not short the strobe pin to ground; it should be current driven at 3 to 5 mA.

Note 10: Refer to RETS111X for the LM111H, LM111J and LM111J-8 military specifications.

Note 11: Human body model, 1.5 k Ω in series with 100 pF.

5.0 Absolute Maximum Ratings for the LM111/LM211 (Note 12)

If Military/Aerospace specified devices are required, please contact the National Semiconductor Sales Office/Distributors for availability and specifications.

Total Supply Voltage (V_{B4})	36V
Output to Negative Supply Voltage (V_{74})	40V
Ground to Negative Supply Voltage (V_{14})	30V
Differential Input Voltage	$\pm 30V$
Input Voltage (Note 13)	$\pm 15V$
Power Dissipation (Note 14)	500 mW
ESD Rating (Note 19)	300V
Output Short Circuit Duration	10 sec

Operating Temperature Range	0° to 70°C
Storage Temperature Range	-65°C to 150°C
Lead Temperature (soldering, 10 sec)	260°C
Voltage at Strobe Pin	$V^+ - 5V$
Soldering Information	
Dual-In-Line Package	
Soldering (10 seconds)	260°C
Small Outline Package	
Vapor Phase (60 seconds)	215°C
Infrared (15 seconds)	220°C
See AN-450 "Surface Mounting Methods and Their Effect on Product Reliability" for other methods of soldering surface mount devices.	

Electrical Characteristics (Note 15) for the LM311

Parameter	Conditions	Min	Typ	Max	Units
Input Offset Voltage (Note 16)	$T_A = 25^\circ C, R_S \leq 50k$		2.0	7.5	mV
Input Offset Current (Note 16)	$T_A = 25^\circ C$		6.0	50	nA
Input Bias Current	$T_A = 25^\circ C$		100	250	nA
Voltage Gain	$T_A = 25^\circ C$	40	200		V/mV
Response Time (Note 17)	$T_A = 25^\circ C$		200		ns
Saturation Voltage	$V_{IN} \leq -10$ mV, $I_{OUT} = 50$ mA $T_A = 25^\circ C$		0.75	1.5	V
Strobe ON Current (Note 18)	$T_A = 25^\circ C$		2.0	5.0	mA
Output Leakage Current	$V_{IN} \geq 10$ mV, $V_{OUT} = 35V$ $T_A = 25^\circ C, I_{STROBE} = 3$ mA $V^- = \text{Pin } 1 = -5V$		0.2	50	nA
Input Offset Voltage (Note 16)	$R_S \leq 50K$			10	mV
Input Offset Current (Note 16)				70	nA
Input Bias Current				300	nA
Input Voltage Range		-14.5	13.8, -14.7	13.0	V
Saturation Voltage	$V^+ \geq 4.5V, V^- = 0$ $V_{IN} \leq -10$ mV, $I_{OUT} \leq 8$ mA		0.23	0.4	V
Positive Supply Current	$T_A = 25^\circ C$		5.1	7.5	mA
Negative Supply Current	$T_A = 25^\circ C$		4.1	5.0	mA

Note 12: "Absolute Maximum Ratings indicate limits beyond which damage to the device may occur. Operating Ratings indicate conditions for which the device is functional, but do not guarantee specific performance limits."

Note 13: This rating applies for $\pm 15V$ supplies. The positive input voltage limit is 30V above the negative supply. The negative input voltage limit is equal to the negative supply voltage or 30V below the positive supply, whichever is less.

Note 14: The maximum junction temperature of the LM311 is 110°C. For operating at elevated temperature, devices in the H08 package must be derated based on a thermal resistance of 165°C/W, junction to ambient, or 20°C/W, junction to case. The thermal resistance of the dual-in-line package is 100°C/W, junction to ambient.

Note 15: These specifications apply for $V_S = \pm 15V$ and Pin 1 at ground, and $0^\circ C < T_A < +70^\circ C$, unless otherwise specified. The offset voltage, offset current and bias current specifications apply for any supply voltage from a single 5V supply up to $\pm 15V$ supplies.

Note 16: The offset voltages and offset currents given are the maximum values required to drive the output within a volt of either supply with 1 mA load. Thus, these parameters define an error band and take into account the worst-case effects of voltage gain and R_S .

Note 17: The response time specified (see definitions) is for a 100 mV input step with 5 mV overdrive.

Note 18: This specification gives the range of current which must be drawn from the strobe pin to ensure the output is properly disabled. Do not short the strobe pin to ground; it should be current driven at 3 to 5 mA.

Note 19: Human body model, 1.5 k Ω in series with 100 pF.

6.0 LM111/LM211 Typical Performance Characteristics

Input Bias Current

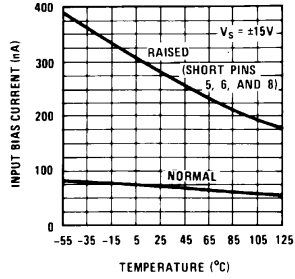

Input Offset Current

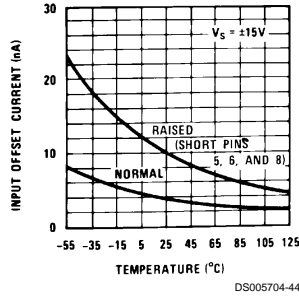

Offset Error

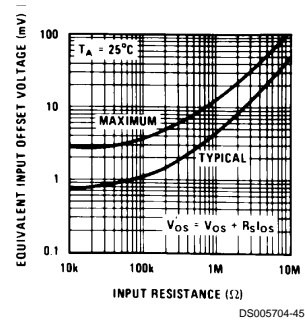

Input Characteristics

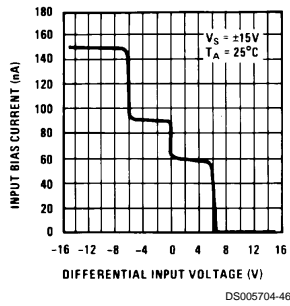

Common Mode Limits

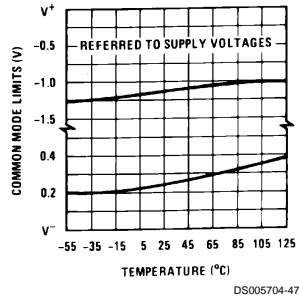

Transfer Function

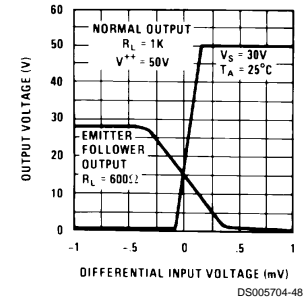

Response Time for Various Input Overdrives

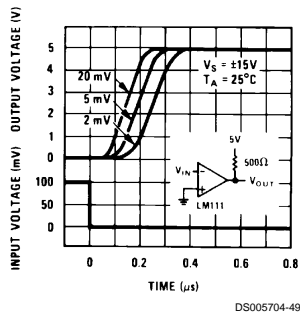

Response Time for Various Input Overdrives

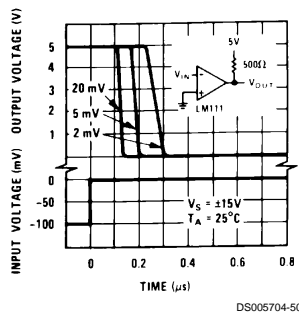

Output Saturation Voltage

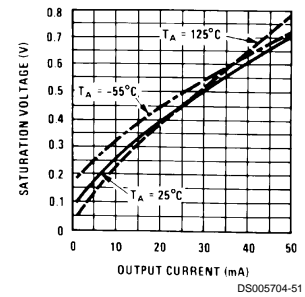

6.0 LM111/LM211 Typical Performance Characteristics (Continued)

Response Time for Various Input Overdrives

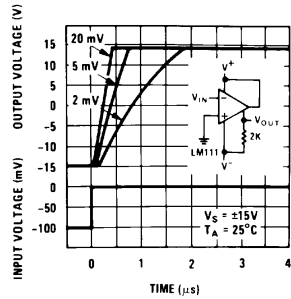

DS005704-52

Response Time for Various Input Overdrives

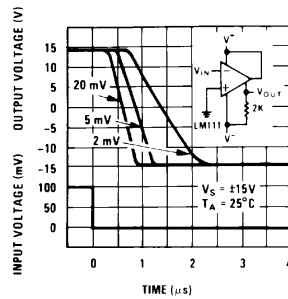

DS005704-53

Output Limiting Characteristics

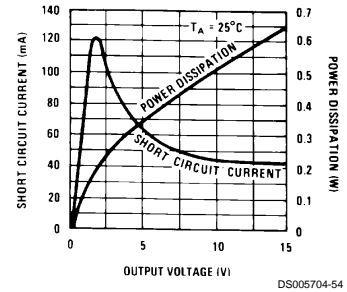

DS005704-54

Supply Current

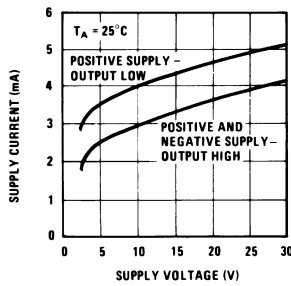

DS005704-55

Supply Current

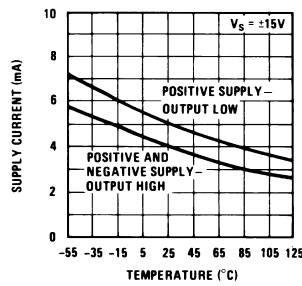

DS005704-56

Leakage Currents

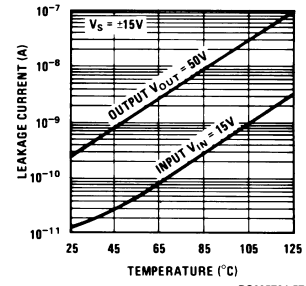

DS005704-57

7.0 LM311 Typical Performance Characteristics

Input Bias Current

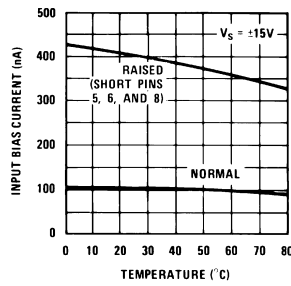

DS005704-58

Input Offset Current

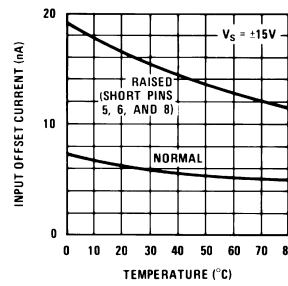

DS005704-59

Offset Error

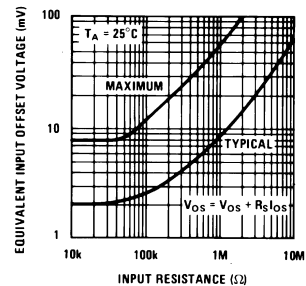

DS005704-60

7.0 LM311 Typical Performance Characteristics (Continued)

Input Characteristics

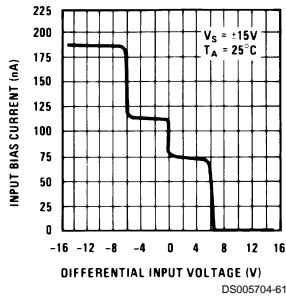

Common Mode Limits

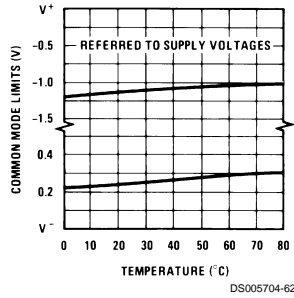

Transfer Function

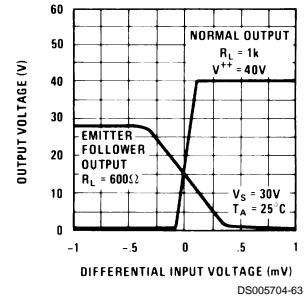

Response Time for Various Input Overdrives

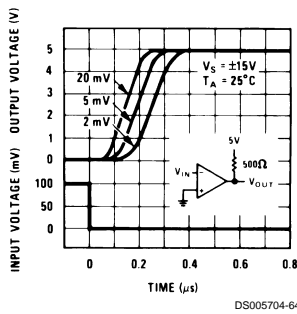

Response Time for Various Input Overdrives

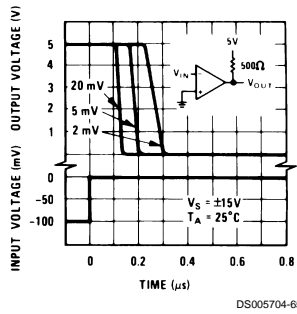

Output Saturation Voltage

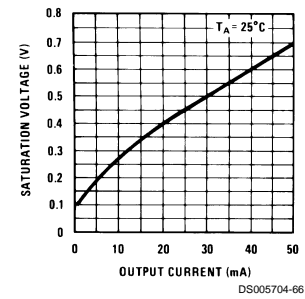

Response Time for Various Input Overdrives

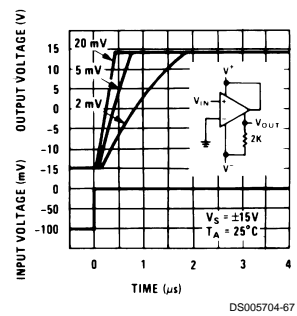

Response Time for Various Input Overdrives

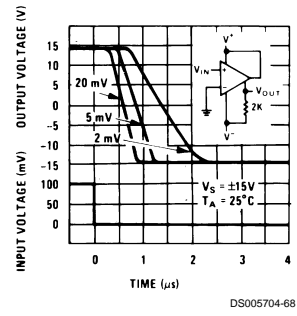

Output Limiting Characteristics

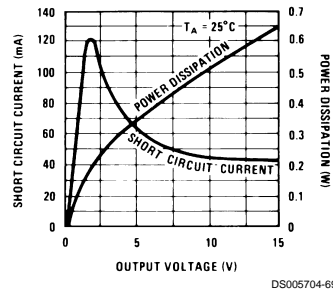

7.0 LM311 Typical Performance Characteristics (Continued)

Supply Current

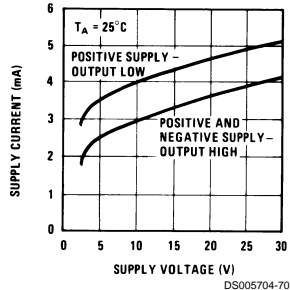

Supply Current

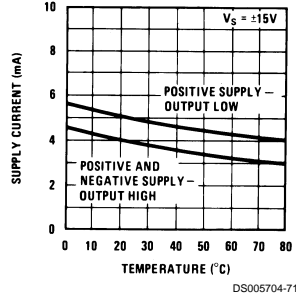

Leakage Currents

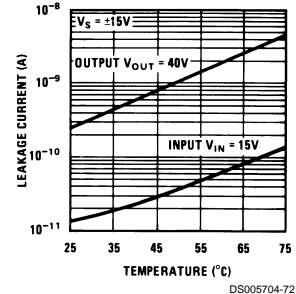

8.0 Application Hints

8.1 CIRCUIT TECHNIQUES FOR AVOIDING OSCILLATIONS IN COMPARATOR APPLICATIONS

When a high-speed comparator such as the LM111 is used with fast input signals and low source impedances, the output response will normally be fast and stable, assuming that the power supplies have been bypassed (with 0.1 μF disc capacitors), and that the output signal is routed well away from the inputs (pins 2 and 3) and also away from pins 5 and 6.

However, when the input signal is a voltage ramp or a slow sine wave, or if the signal source impedance is high (1 $\text{k}\Omega$ to 100 $\text{k}\Omega$), the comparator may burst into oscillation near the crossing-point. This is due to the high gain and wide bandwidth of comparators like the LM111. To avoid oscillation or instability in such a usage, several precautions are recommended, as shown in *Figure 1* below.

1. The trim pins (pins 5 and 6) act as unwanted auxiliary inputs. If these pins are not connected to a trim-pot, they should be shorted together. If they are connected to a trim-pot, a 0.01 μF capacitor C1 between pins 5 and 6 will minimize the susceptibility to AC coupling. A smaller capacitor is used if pin 5 is used for positive feedback as in *Figure 1*.
2. Certain sources will produce a cleaner comparator output waveform if a 100 pF to 1000 pF capacitor C2 is connected directly across the input pins.
3. When the signal source is applied through a resistive network, R_S , it is usually advantageous to choose an R_S of substantially the same value, both for DC and for dynamic (AC) considerations. Carbon, tin-oxide, and metal-film resistors have all been used successfully in comparator input circuitry. Inductive wirewound resistors are not suitable.
4. When comparator circuits use input resistors (eg. summing resistors), their value and placement are particularly important. In all cases the body of the resistor should be close to the device or socket. In other words there should be very little lead length or printed-circuit foil run between comparator and resistor to radiate or pick up signals. The same applies to capacitors, pots, etc. For example, if $R_S=10 \text{ k}\Omega$, as little as 5 inches of lead between the resistors and the input pins can result in oscillations that are very hard to damp. Twisting these input leads tightly is the only (second best) alternative to placing resistors close to the comparator.

5. Since feedback to almost any pin of a comparator can result in oscillation, the printed-circuit layout should be engineered thoughtfully. Preferably there should be a groundplane under the LM111 circuitry, for example, one side of a double-layer circuit card. Ground foil (or, positive supply or negative supply foil) should extend between the output and the inputs, to act as a guard. The foil connections for the inputs should be as small and compact as possible, and should be essentially surrounded by ground foil on all sides, to guard against capacitive coupling from any high-level signals (such as the output). If pins 5 and 6 are not used, they should be shorted together. If they are connected to a trim-pot, the trim-pot should be located, at most, a few inches away from the LM111, and the 0.01 μF capacitor should be installed. If this capacitor cannot be used, a shielding printed-circuit foil may be advisable between pins 6 and 7. The power supply bypass capacitors should be located within a couple inches of the LM111. (Some other comparators require the power-supply bypass to be located immediately adjacent to the comparator.)
6. It is a standard procedure to use hysteresis (positive feedback) around a comparator, to prevent oscillation, and to avoid excessive noise on the output because the comparator is a good amplifier for its own noise. In the circuit of *Figure 2*, the feedback from the output to the positive input will cause about 3 mV of hysteresis. However, if R_S is larger than 100 Ω , such as 50 $\text{k}\Omega$, it would not be reasonable to simply increase the value of the positive feedback resistor above 510 $\text{k}\Omega$. The circuit of *Figure 3* could be used, but it is rather awkward. See the notes in paragraph 7 below.
7. When both inputs of the LM111 are connected to active signals, or if a high-impedance signal is driving the positive input of the LM111 so that positive feedback would be disruptive, the circuit of *Figure 1* is ideal. The positive feedback is to pin 5 (one of the offset adjustment pins). It is sufficient to cause 1 to 2 mV hysteresis and sharp transitions with input triangle waves from a few Hz to hundreds of kHz. The positive-feedback signal across the 82 Ω resistor swings 240 mV below the positive supply. This signal is centered around the nominal voltage at pin 5, so this feedback does not add to the V_{OS} of the comparator. As much as 8 mV of V_{OS} can be trimmed out, using the 5 $\text{k}\Omega$ pot and 3 $\text{k}\Omega$ resistor as shown.

8.0 Application Hints (Continued)

8. These application notes apply specifically to the LM111, LM211, LM311, and LF111 families of comparators, and

are applicable to all high-speed comparators in general, (with the exception that not all comparators have trim pins).

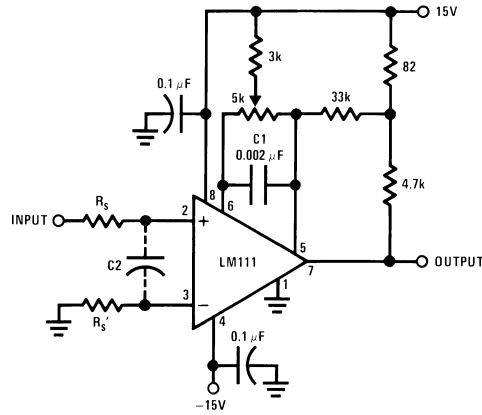

DS005704-29

Pin connections shown are for LM111H in the H08 hermetic package

FIGURE 1. Improved Positive Feedback

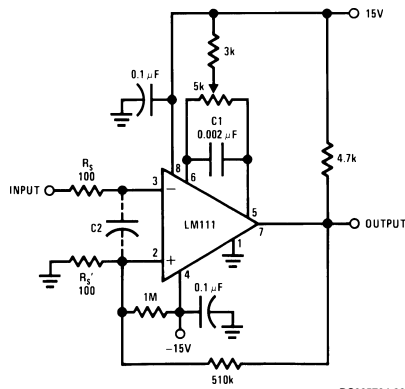

DS005704-30

Pin connections shown are for LM111H in the H08 hermetic package

FIGURE 2. Conventional Positive Feedback

8.0 Application Hints (Continued)

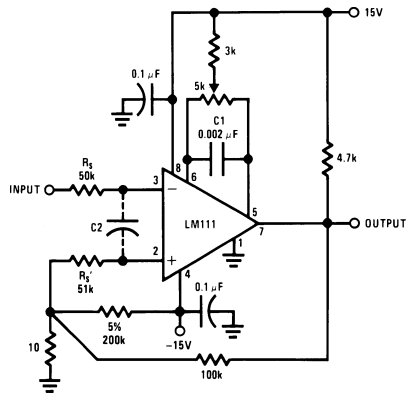

DS005704-31

FIGURE 3. Positive Feedback with High Source Resistance

9.0 Typical Applications (Pin numbers refer to H08 package)

Zero Crossing Detector Driving MOS Switch

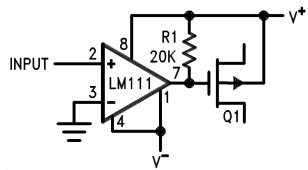

DS005704-13

100 kHz Free Running Multivibrator

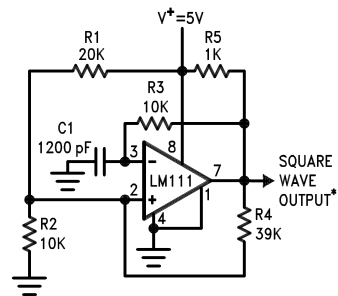

DS005704-14

*TTL or DTL fanout of two

9.0 Typical Applications (Pin numbers refer to H08 package) (Continued)

10 Hz to 10 kHz Voltage Controlled Oscillator

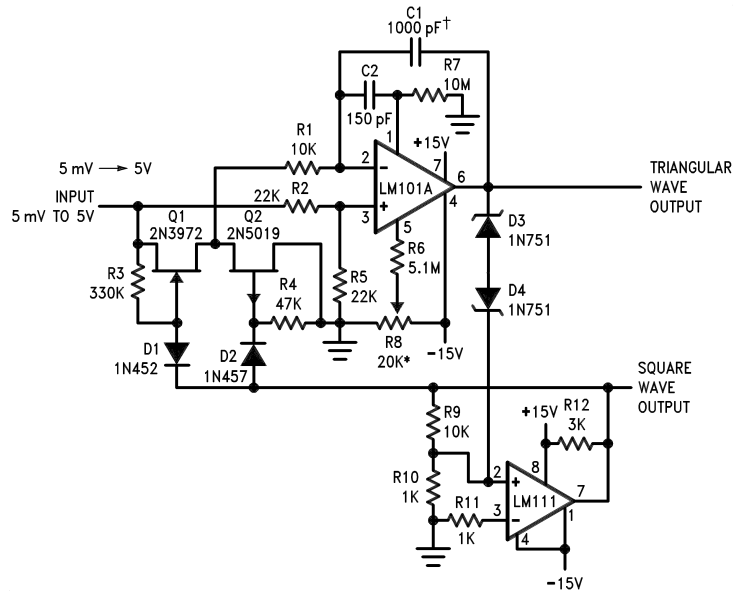

DS005704-15

*Adjust for symmetrical square wave time when $V_{IN} = 5 \text{ mV}$
 †Minimum capacitance 20 pF Maximum frequency 50 kHz

Driving Ground-Referred Load

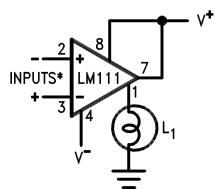

DS005704-16

*Input polarity is reversed when using pin 1 as output.

Using Clamp Diodes to Improve Response

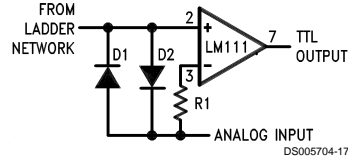

DS005704-17

TTL Interface with High Level Logic

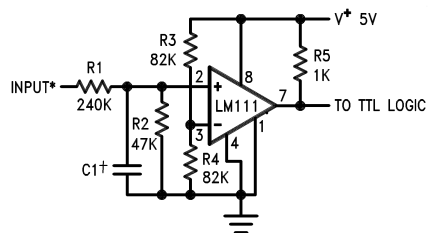

DS005704-18

*Values shown are for a 0 to 30V logic swing and a 15V threshold.
 †May be added to control speed and reduce susceptibility to noise spikes.

9.0 Typical Applications (Pin numbers refer to H08 package) (Continued)

Crystal Oscillator

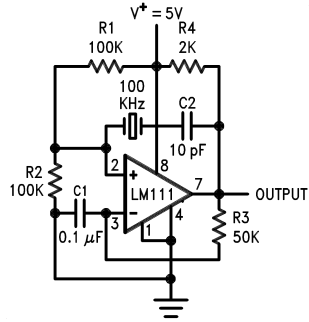

DS005704-19

Comparator and Solenoid Driver

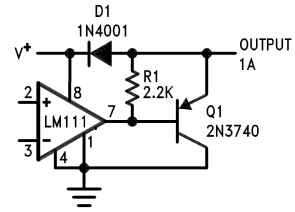

DS005704-20

Precision Squarer

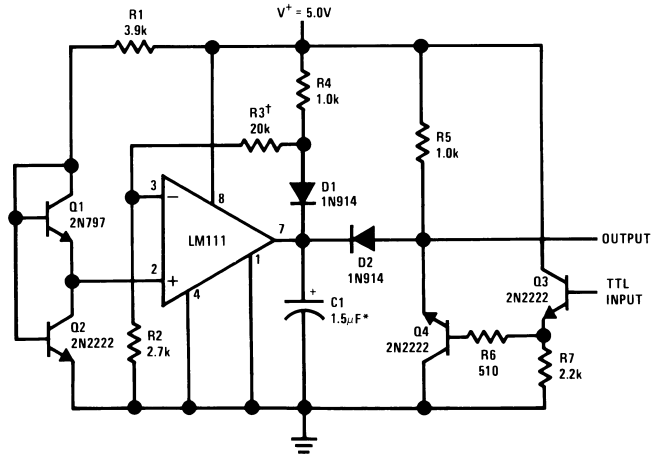

DS005704-21

*Solid tantalum

†Adjust to set clamp level

9.0 Typical Applications (Pin numbers refer to H08 package) (Continued)

Low Voltage Adjustable Reference Supply

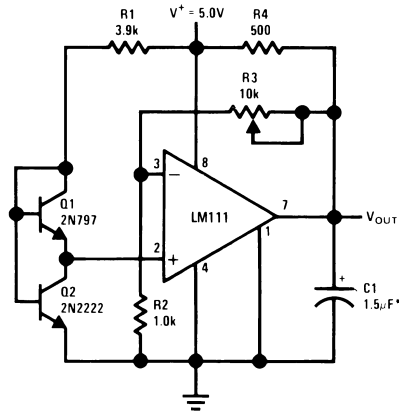

DS005704-22

*Solid tantalum

Positive Peak Detector

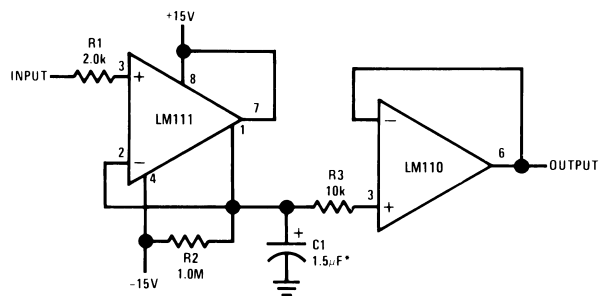

DS005704-23

*Solid tantalum

Zero Crossing Detector Driving MOS Logic

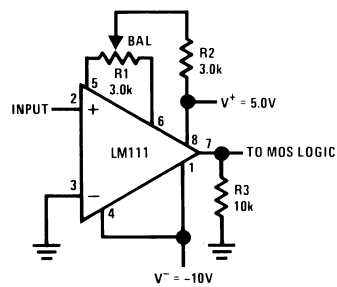

DS005704-24

Negative Peak Detector

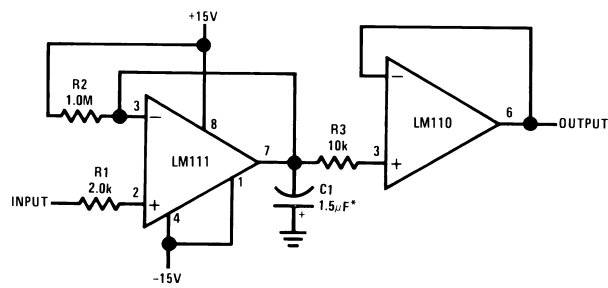

DS005704-25

*Solid tantalum

9.0 Typical Applications (Pin numbers refer to H08 package) (Continued)

Precision Photodiode Comparator

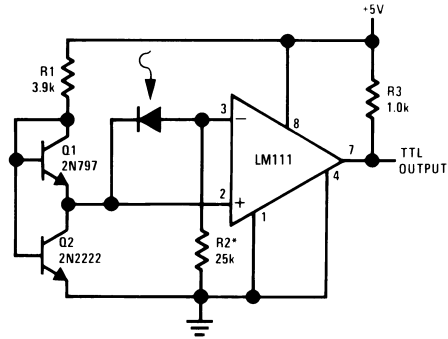

DS005704-26

*R2 sets the comparison level. At comparison, the photodiode has less than 5 mV across it, decreasing leakages by an order of magnitude.

Switching Power Amplifier

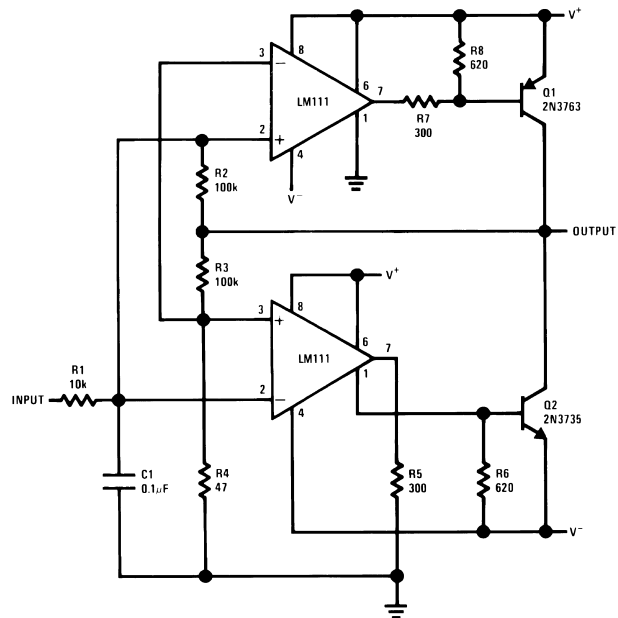

DS005704-27

9.0 Typical Applications (Pin numbers refer to H08 package) (Continued)

Switching Power Amplifier

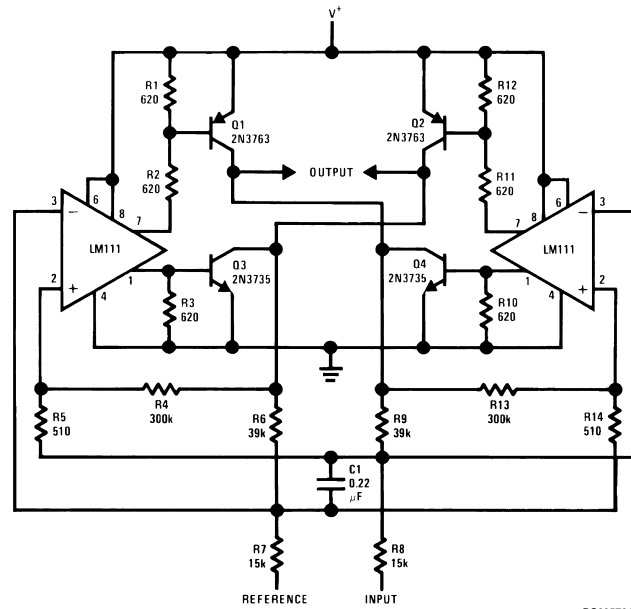

DS005704-28

10.0 Schematic Diagram (Note 20)

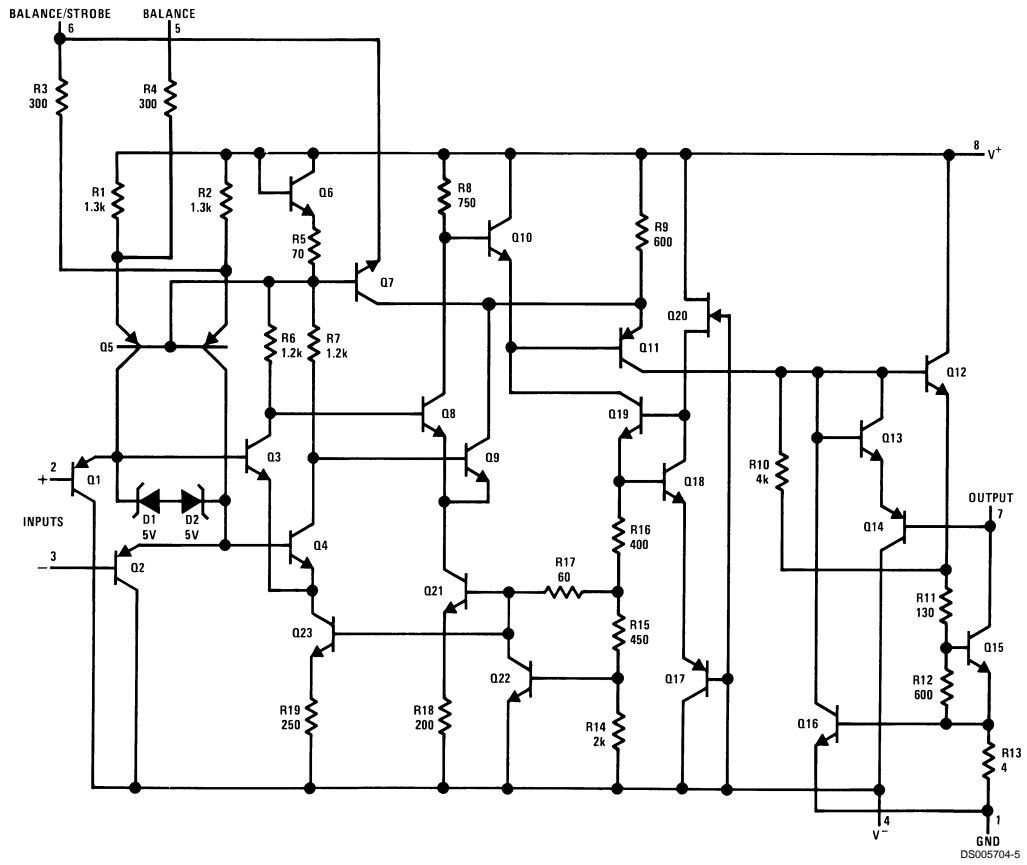

Note 20: Pin connections shown on schematic diagram are for H08 package.

11.0 Connection Diagrams

Metal Can Package

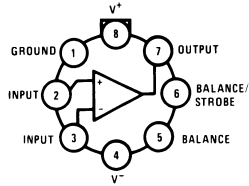

DS005704-6

Note: Pin 4 connected to case

Top View

Order Number LM111H, LM111H/883(Note 21) , LM211H or LM311H
See NS Package Number H08C

Dual-In-Line Package

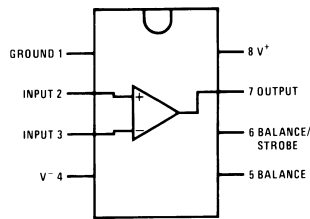

DS005704-34

Top View

Order Number LM111J-8, LM111J-8/883(Note 21) ,
LM211J-8, LM211M, LM311M or LM311N
See NS Package Number J08A, M08A or N08E

Dual-In-Line Package

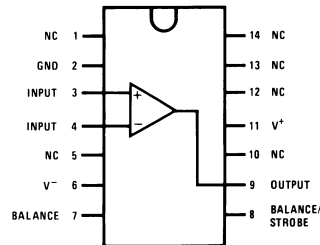

DS005704-35

Top View

Order Number LM111J/883(Note 21) or LM311N-14
See NS Package Number J14A or N14A

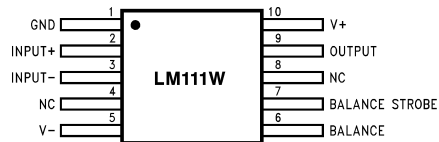

DS005704-33

Order Number LM111W/883(Note 21), LM111WG/883
See NS Package Number W10A, WG10A

Note 21: Also available per JM38510/10304

12.0 Physical Dimensions inches (millimeters) unless otherwise noted

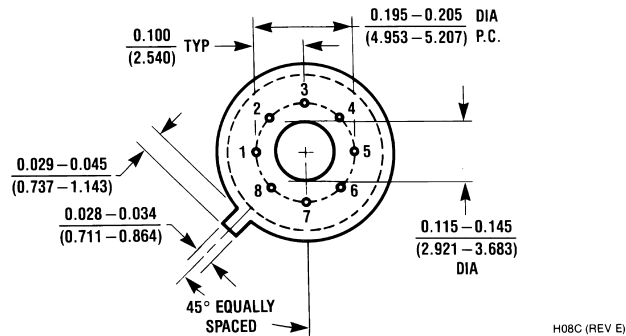
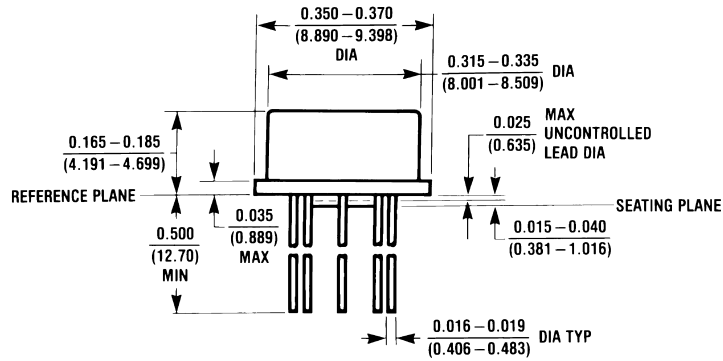

Metal Can Package (H)
 Order Number LM111H, LM111H/883, LM211H or LM311H
 NS Package Number H08C

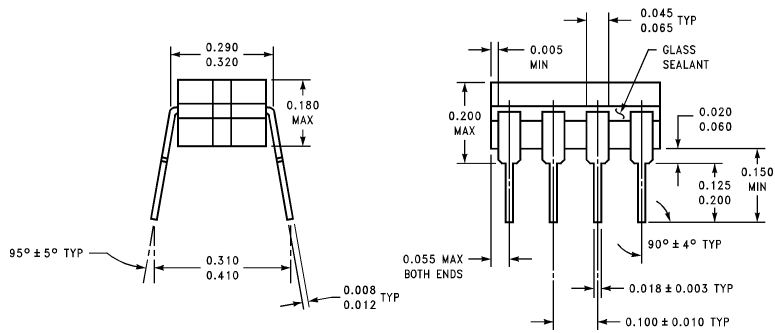
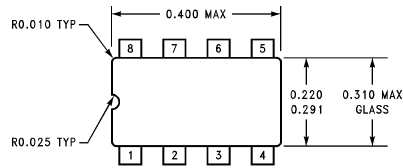

Cavity Dual-In-Line Package (J)
 Order Number LM111J-8, LM111J-8/883 or LM211J-8
 NS Package Number J08A

12.0 Physical Dimensions inches (millimeters) unless otherwise noted (Continued)

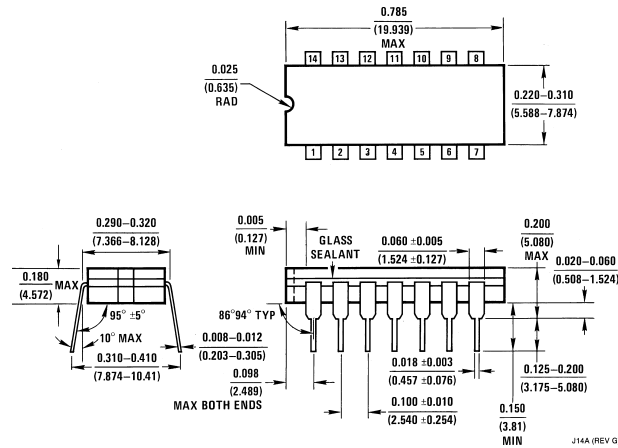

Dual-In-Line Package (J)
Order Number LM111J/883
NS Package Number J14A

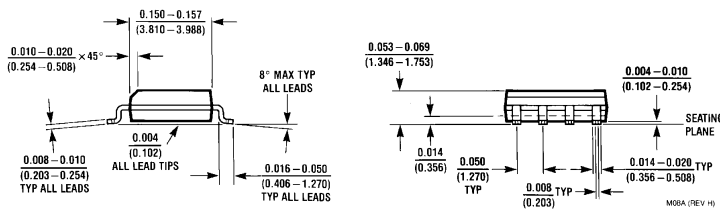
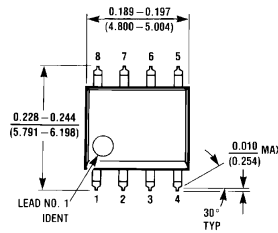

Dual-In-Line Package (M)
Order Number LM211M or LM311M
NS Package Number M08A

12.0 Physical Dimensions inches (millimeters) unless otherwise noted (Continued)

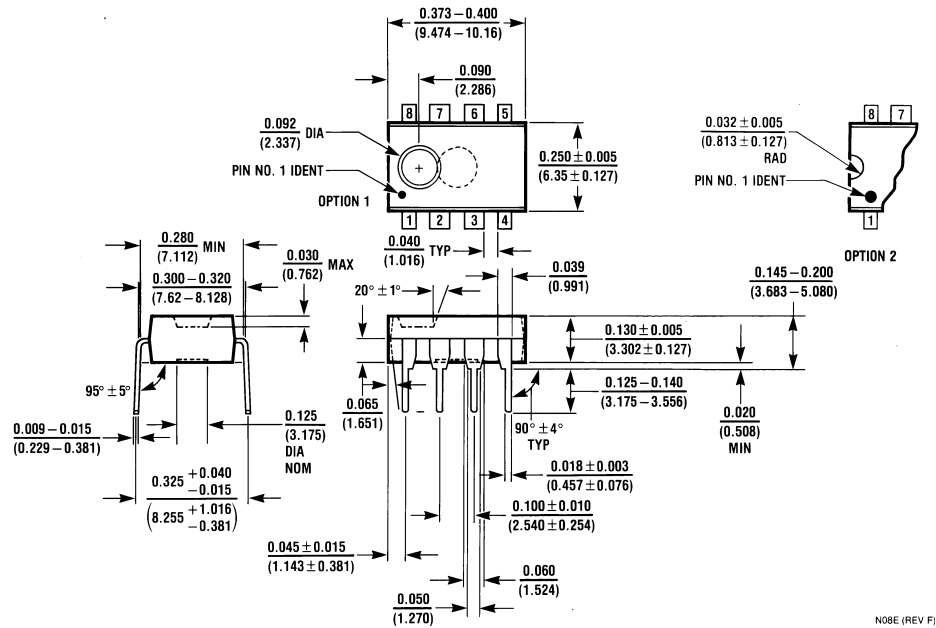

Dual-In-Line Package (N)
Order Number LM311N
NS Package Number N08E

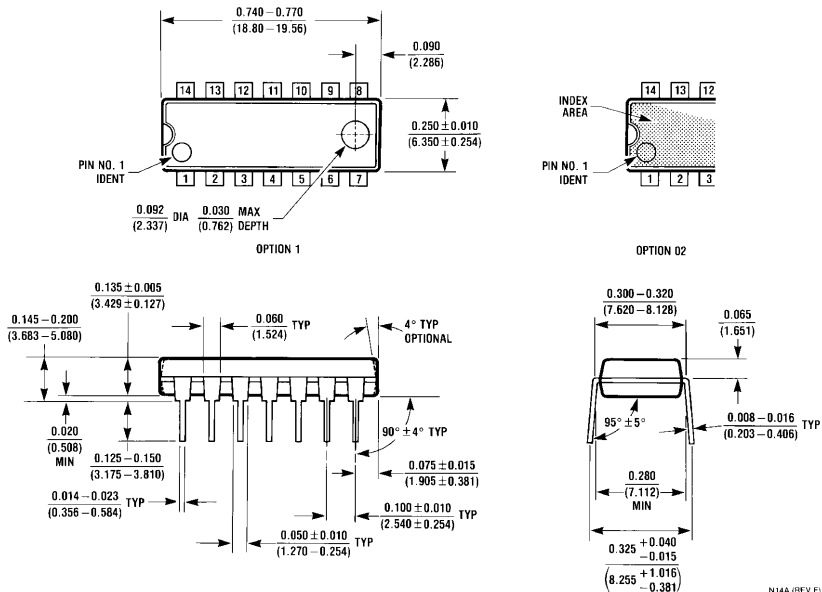

Dual-In-Line Package (N)
Order Number LM311N-14
NS Package Number N14A

12.0 Physical Dimensions inches (millimeters) unless otherwise noted (Continued)

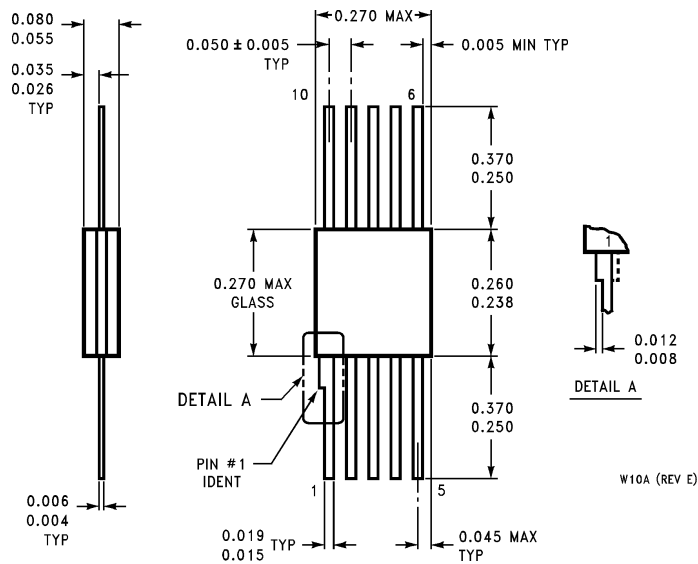

**Order Number LM111W/883, LM111WG/883
NS Package Number W10A, WG10A**

LIFE SUPPORT POLICY

NATIONAL'S PRODUCTS ARE NOT AUTHORIZED FOR USE AS CRITICAL COMPONENTS IN LIFE SUPPORT DEVICES OR SYSTEMS WITHOUT THE EXPRESS WRITTEN APPROVAL OF THE PRESIDENT AND GENERAL COUNSEL OF NATIONAL SEMICONDUCTOR CORPORATION. As used herein:

1. Life support devices or systems are devices or systems which, (a) are intended for surgical implant into the body, or (b) support or sustain life, and whose failure to perform when properly used in accordance with instructions for use provided in the labeling, can be reasonably expected to result in a significant injury to the user.
2. A critical component is any component of a life support device or system whose failure to perform can be reasonably expected to cause the failure of the life support device or system, or to affect its safety or effectiveness.

National Semiconductor Corporation
Americas
Tel: 1-800-272-9959
Fax: 1-800-737-7018
Email: support@nsc.com

www.national.com

National Semiconductor Europe
Fax: +49 (0) 1 80-530 85 86
Email: europe.support@nsc.com
Deutsch Tel: +49 (0) 1 80-530 85 85
English Tel: +49 (0) 1 80-532 78 32
Français Tel: +49 (0) 1 80-532 93 58
Italiano Tel: +49 (0) 1 80-534 16 80

National Semiconductor Asia Pacific Customer Response Group
Tel: 65-2544466
Fax: 65-2504466
Email: sea.support@nsc.com

National Semiconductor Japan Ltd.
Tel: 81-3-5639-7560
Fax: 81-3-5639-7507

This datasheet has been downloaded from:

www.DatasheetCatalog.com

Datasheets for electronic components.

National Semiconductor was acquired by Texas Instruments.

http://www.ti.com/corp/docs/investor_relations/pr_09_23_2011_national_semiconductor.html

This file is the datasheet for the following electronic components:

LM211J-8 - <http://www.ti.com/product/lm211j-8?HQS=TI-null-null-dscatalog-df-pf-null-wwe>

LM211M - <http://www.ti.com/product/lm211m?HQS=TI-null-null-dscatalog-df-pf-null-wwe>

LM311N-14 - <http://www.ti.com/product/lm311n-14?HQS=TI-null-null-dscatalog-df-pf-null-wwe>