

ENGINEERING DATA SHEET

M502

RELAY - LATCH
3 PDT, 25 AMP



Polarized, latching hermetically sealed relay

Contact arrangement **3 PDT**
Coil supply **Direct current**
Meets the requirements of **MS 27742**

PRINCIPLE TECHNICAL CHARACTERISTICS

Contacts rated at **28 Vdc; 115 Vac, 400 Hz**
Weight **85 grams max**
Dimensions max. of case in mm **26 x 25.7 x 26**
Balanced-force design
Hermetically sealed, resistant protected metal can

APPLICATION NOTES:

[001](#)
[007](#)
[023](#)

APPLICABLE SOCKET:

[S502](#)

CONTACT ELECTRICAL CHARACTERISTICS

Minimum operating cycles	Contact rating per pole and load type	Load Current in Amps		
		@28 Vdc	@115 Vac, 400 Hz	@115/200 Vac, 400 Hz
50,000 cycles	resistive load	25	25	25
10,000 cycles	inductive load (L/R=5ms)	12	15	15
50,000 cycles	motor load	10	10	10
50,000 cycles	lamp load	5	5	5
50 cycles	resistive overload	50	80	
200,000 cycles	at 25% rated resistive load			



Featuring **LEACH**® power and control solutions
www.esterline.com

AMERICAS
6900 Orangethorpe Ave.
P.O. Box 5032
Buena Park, CA 90622

Tel: (01) 714-736-7599
Fax: (01) 714-670-1145

EUROPE
2 Rue Goethe
57430 Sarralbe
France

Tel: (33) 3 87 97 31 01
Fax: (33) 3 87 97 96 86

ASIA
Units 602-603 6/F Lakeside 1
No.8 Science Park West Avenue
Phase Two, Hong Kong Science Park
Pak Shek Kok, Tai Po, N.T.
Hong Kong
Tel: (852) 2 191 3830
Fax: (852) 2 389 5803

Data sheets are for initial product selection and comparison. Contact Esterline Power Systems prior to choosing a component.

COIL CHARACTERISTICS (Vdc)**M502**

CODE	A	B	C	N
Nominal operating voltage	28	12	6	28
Maximum operating voltage	29	14.5	7.3	29
Maximum latching voltage at +125° C	18	9	4.5	18
Maximum reset voltage at +125° C	18	9	4.5	18
Coil resistance $\Omega \pm 10\%$ at +25° C	450	112	28	450
Back EMF suppressed to (Vdc)	N/A	N/A	N/A	-5

GENERAL CHARACTERISTICS

Temperature range	-65°C to +125°C
Dielectric strength at sea level	
- Contacts to ground and between contacts	1250 Vrms / 50 Hz
- Coil to ground	1000 Vrms / 50 Hz
Dielectric strength at altitude 25,000 m (all points)	350 Vrms / 50 Hz
Initial insulation resistance at 500 Vdc	100 M Ω min.
Sinusoidal vibration (except G and O mounting)	30G / 75 to 3000 Hz
Sinusoidal vibration (G and O mounting only)	20G / 75 to 3000 Hz
Shock (except G and O mounting)	200G / 6 ms
Shock (G and O mounting only)	50G / 11 ms
Maximum contact opening time under vibration and shock	10 μ s
Operate time at nominal voltage	15 ms max
Release time	15 ms max
Bounce time	1 ms max
Contact voltage drop at nominal current	
- initial value	150 mV max
- after life	175 mV max

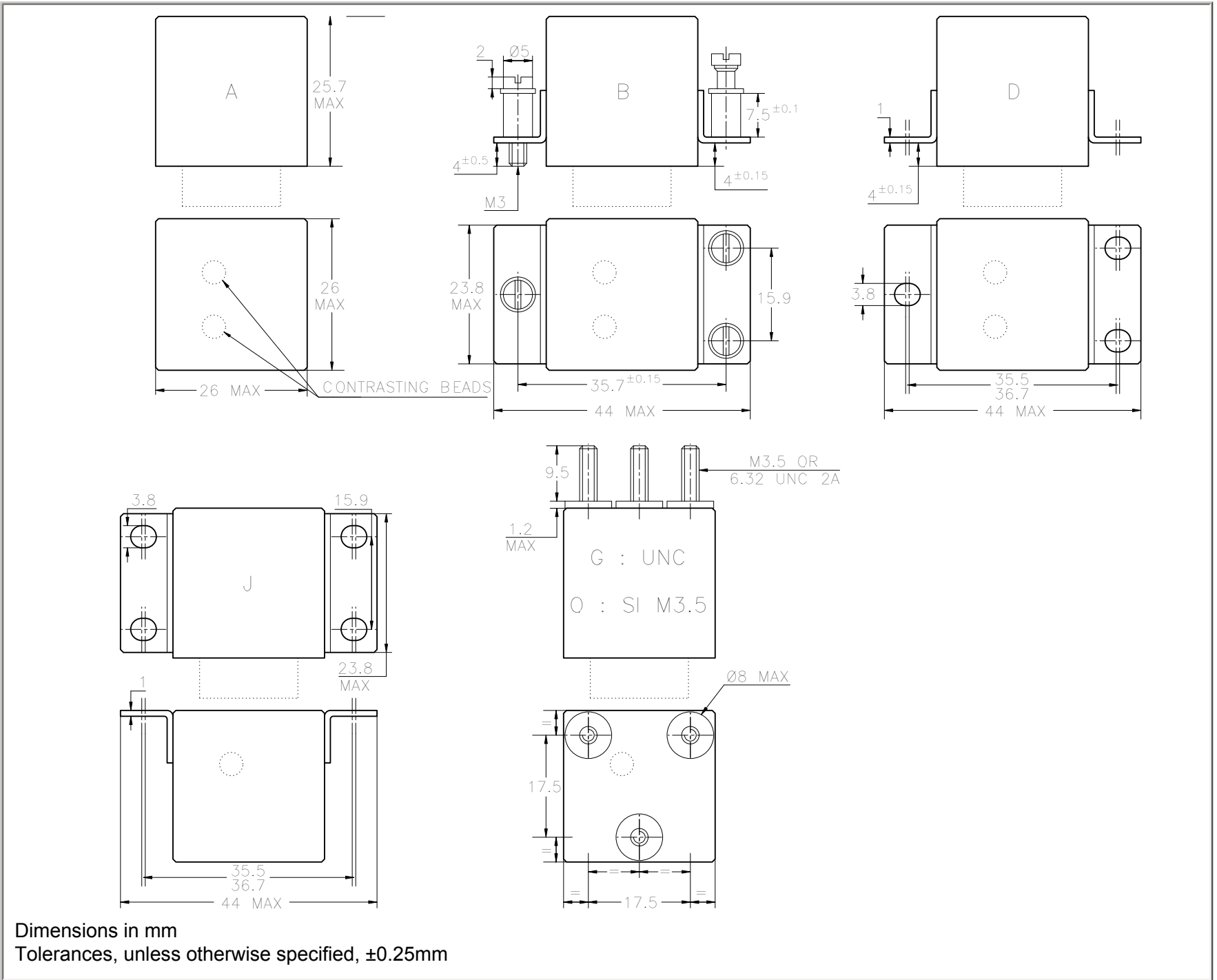

TERMINAL TYPES

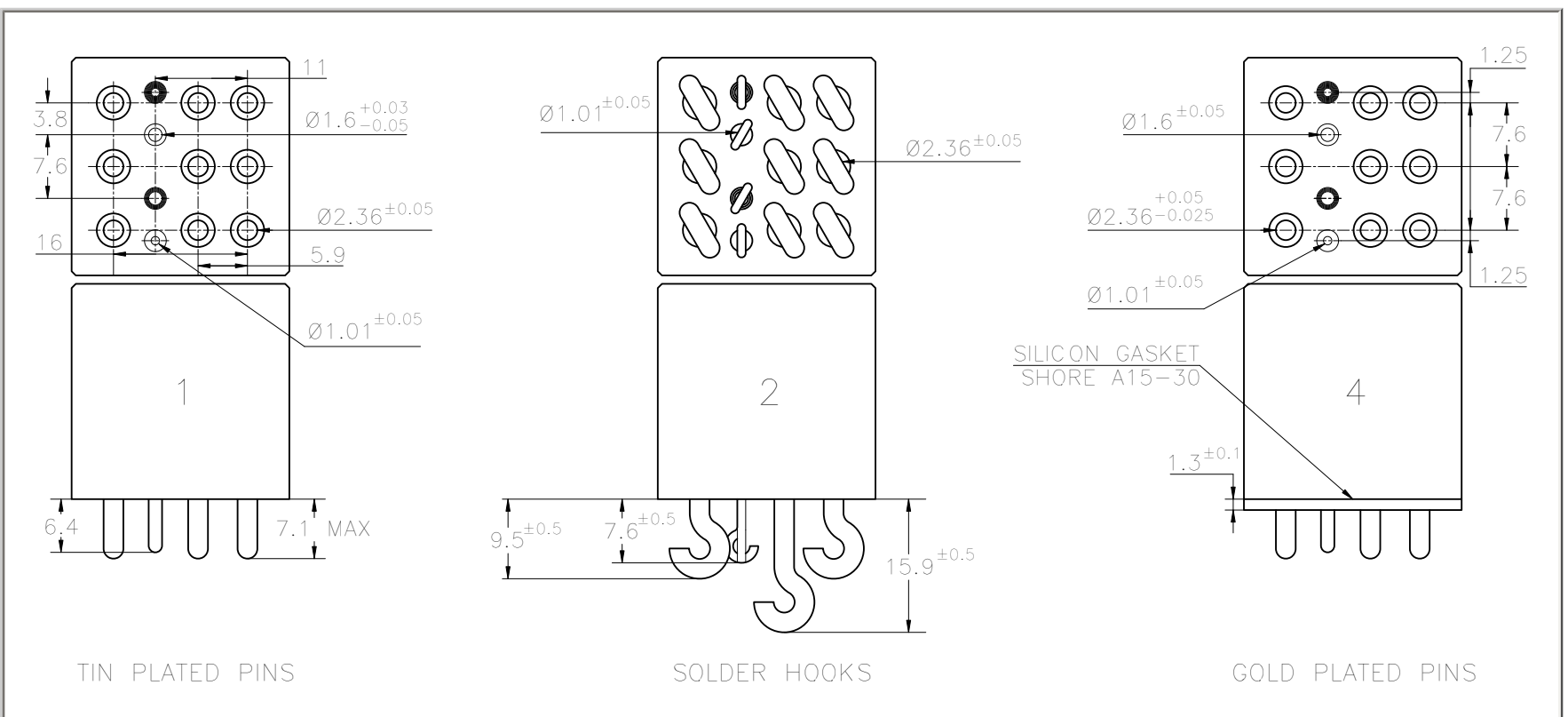

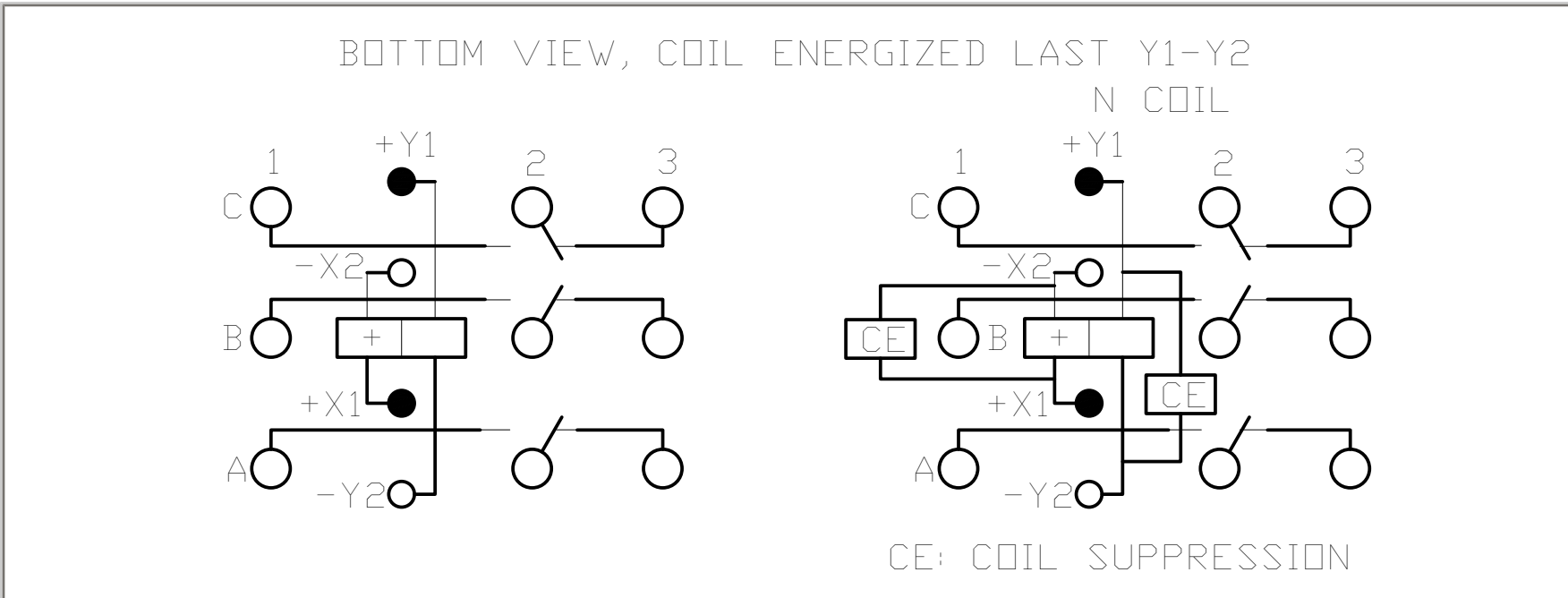

NUMBERING SYSTEM

	M502	A	1	A	D
Basic series designation _____					
1-Mounting Style (A,B,D,G,J,O) _____					
2-Terminal Types (1,2,4) _____					
3-Coil Voltage (A,B,C,N) _____					
4-See Note [4] Below _____					

NOTES

1. Relays with mounting styles B,D and terminal type 4 are compatible with socket families S502...
 2. Isolation spacer pads for PCB mounting available on request.
 3. For other mounting styles or terminal types, please contact the factory.
- [4]. **Options**
- **C:** Circuit breaker compatibility 30 A / 1 hour; 50 A / 5 sec; 100 A / 1.2 sec 250 A / 0.2 sec; 350 A / 0.1 sec
 - **D:** low level: 10 μ A / 10 mV

TYPICAL CHARACTERISTICS

- Coil resistance/temperature change: See application note no. 001

**CORRECTION DUE TO COIL COPPER WIRE RESISTANCE
CHANGE IN TEMPERATURE**

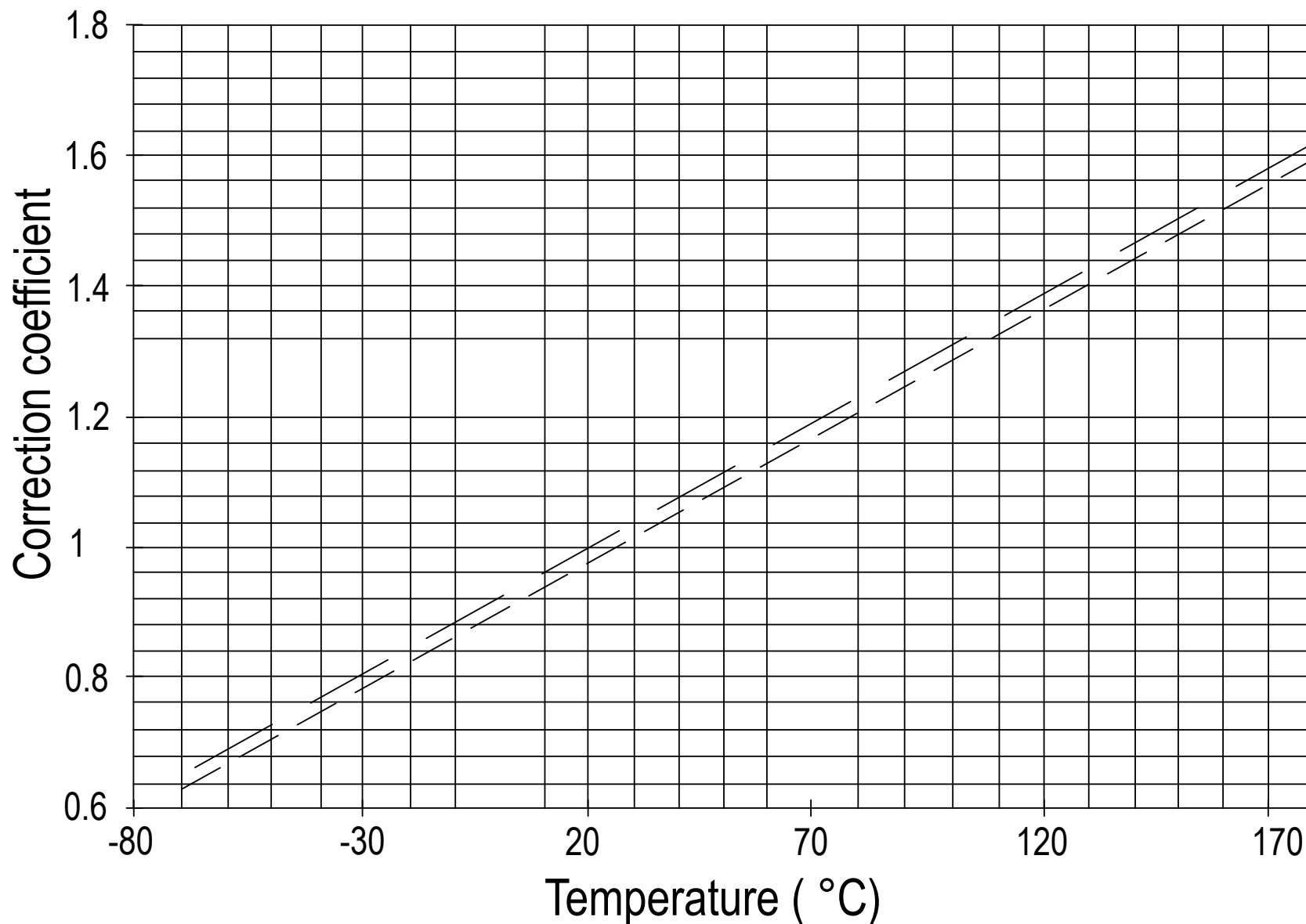

— — Nominal Resistance at 25°C

———— Nominal Resistance at 20°C

Example: Coil resistance at 25°C: 935 ohms. What is it at 125°C?

Correction coefficient on diagram is: 1.39 at 125°C. R becomes: $935 \times 1.39 = 1299$ Ohms

Correction also applies to operating voltages

SUPPRESSOR DEVICES FOR RELAY COILS

The inductive nature of relay coils allows them to create magnetic forces which are converted to mechanical movements to operate contact systems. When voltage is applied to a coil, the resulting current generates a magnetic flux, creating mechanical work. Upon deenergizing the coil, the collapsing magnetic field induces a reverse voltage (also known as back EMF) which tends to maintain current flow in the coil. The induced voltage level mainly depends on the duration of the deenergization. The faster the switch-off, the higher the induced voltage.

All coil suppression networks are based on a reduction of speed of current decay. This reduction may also slow down the opening of contacts, adversely effecting contact life and reliability. Therefore, it is very important to have a clear understanding of these phenomena when designing a coil suppression circuitry.

Typical coil characteristics

On the graph below, the upper record shows the contacts state. (High level NO contacts closed, low level NC contacts closed, intermediate state contact transfer). The lower record shows the voltage across the coil when the current is switched off by another relay contact.

The surge voltage is limited to -300V by the arc generated across contact poles. Discharge duration is about 200 mircoseconds after which the current change does not generate sufficient voltage. The voltage decreases to the point where the contacts start to move, at this time, the voltage increases due to the energy contained in the NO contact springs. The voltage decreases again during transfer, and increases once more when the magnetic circuit is closed on permanent magnet.

- Operating times are as follows:
- Time to start the movement 1.5ms
- Total motion time 2.3ms
- Transfer time 1.4ms

Contact State

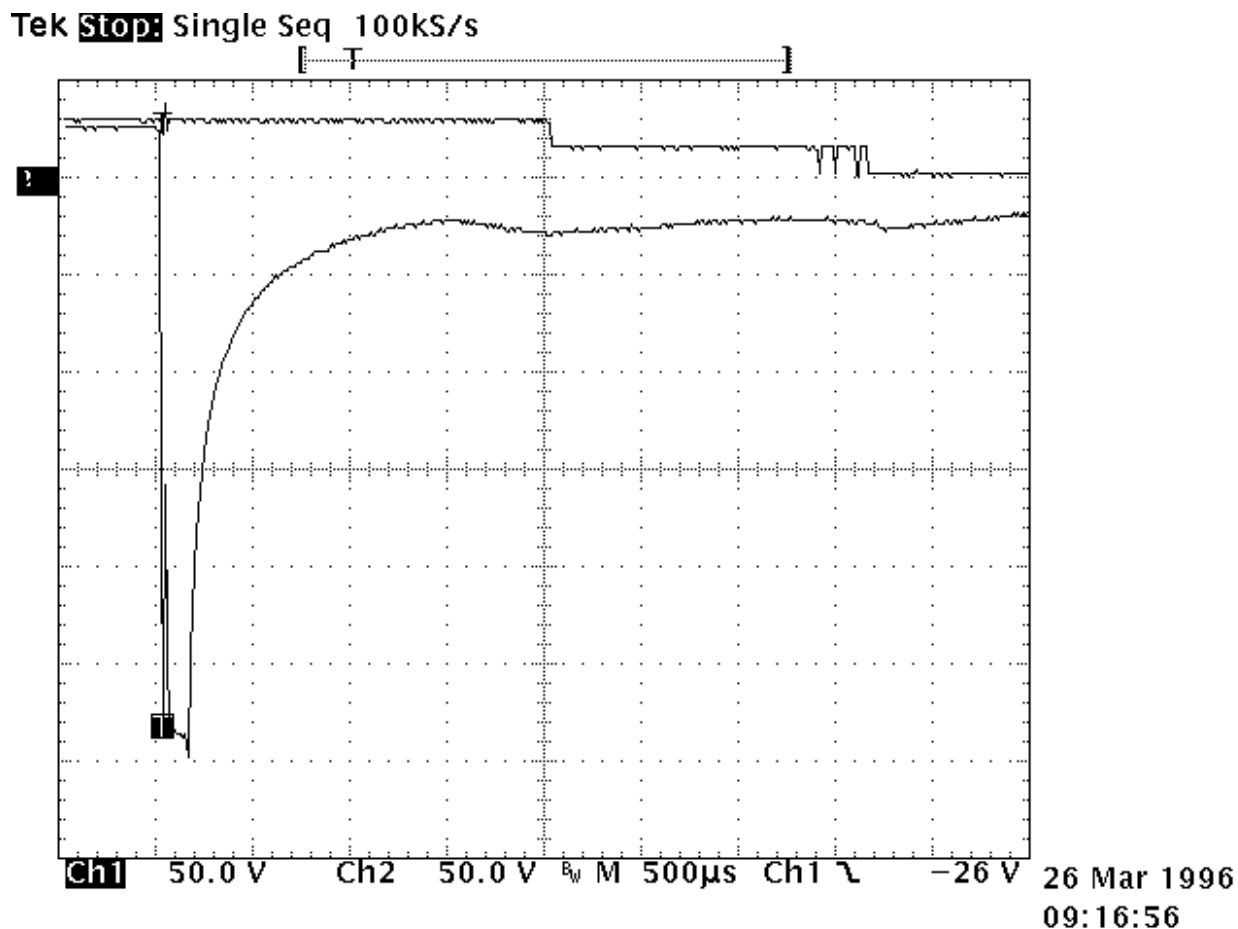

Types of suppressors:

Passive devices.

The resistor capacitor circuit

It eliminates the power dissipation problem, as well as fast voltage rises. With a proper match between coil and resistor, approximate capacitance value can be calculated from:

$$C = 0.02 \times T / R, \text{ where}$$

T = operating time in milliseconds

R = coil resistance in kiloOhms

C = capacitance in microFarads

The series resistor must be between 0.5 and 1 times the coil resistance. Special consideration must be taken for the capacitor inrush current in the case of a low resistance coil.

The record shown opposite is performed on the same relay as above. The operation time becomes:

- time to start the movement 2.3ms

- transfer time 1.2ms

The major difficulty comes from the capacitor volume. In our example of a relay with a 290Ω coil and time delay of 8 ms, a capacitance value of $C=0.5 \mu\text{F}$ is found. This non polarized capacitor, with a voltage of 63V minimum, has a volume of about 1cm^3 . For 150V, this volume becomes 1.5cm^3 .

Tek **Stop**: Single Seq 100kS/s

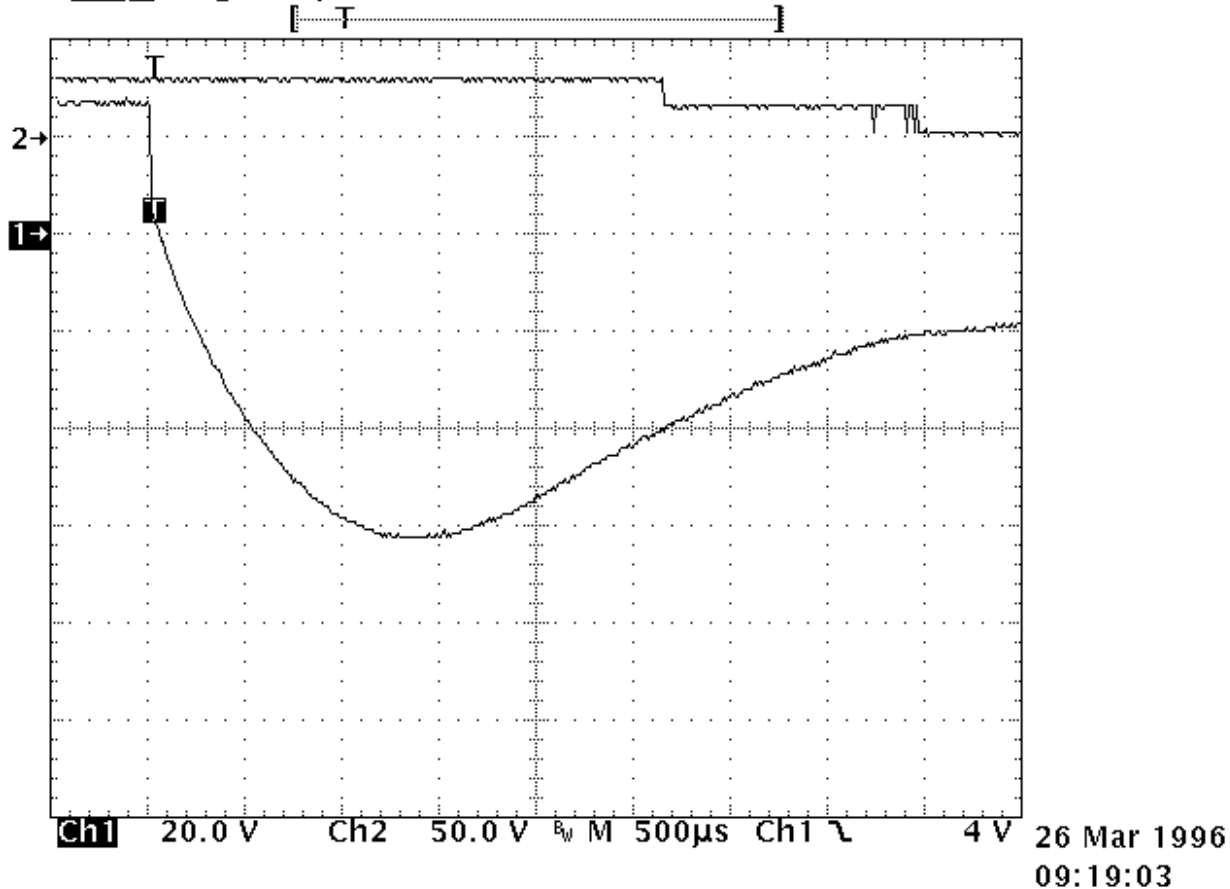

The bifilar coil

The principle is to wind on the magnetic circuit of the main coil a second coil shorted on itself. By a proper adaptation of the internal resistance of this second coil it is possible to find an acceptable equilibrium between surge voltage and reduction of the opening speed. To be efficient at fast voltage changes, the coupling of two coils must be perfect. This implies embedded windings. The volume occupied by the second coil reduces the efficiency of the main coil and results in higher coil power consumption. This method cannot be applied efficiently to products not specifically designed for this purpose.

The resistor (parallel with the coil)

For efficient action, the resistor must be of the same order of magnitude as the coil resistance. A resistor 1.5 times the coil resistance will limit the surge to 1.5 times the supply voltage. Release time and opening speed are moderately affected. The major problem is the extra power dissipated.

Semi-conductor devices

The diode

It is the most simple method to totally suppress the surge voltage. It has the major disadvantage of the higher reduction of contact opening speed. This is due to the total recycling, through the diode, of the energy contained in the coil itself. The following measurement is performed once again on the same relay. Operation times are given by the upper curve:

- time to start the movement 14ms
- transfer time 5ms

These times are multiplied by a coefficient from 4 to 8.

The lower curve shows the coil current. The increase prior to NO contact opening indicates that the contact spring dissipates its energy. At the opening time the current becomes constant as a result of practically zero opening speed.

Due to this kind of behavior, this type of suppression must be avoided for power relays. For small relays which have to switch low currents of less than 0.2 A, degradation of life is not that significant and the method may be acceptable.

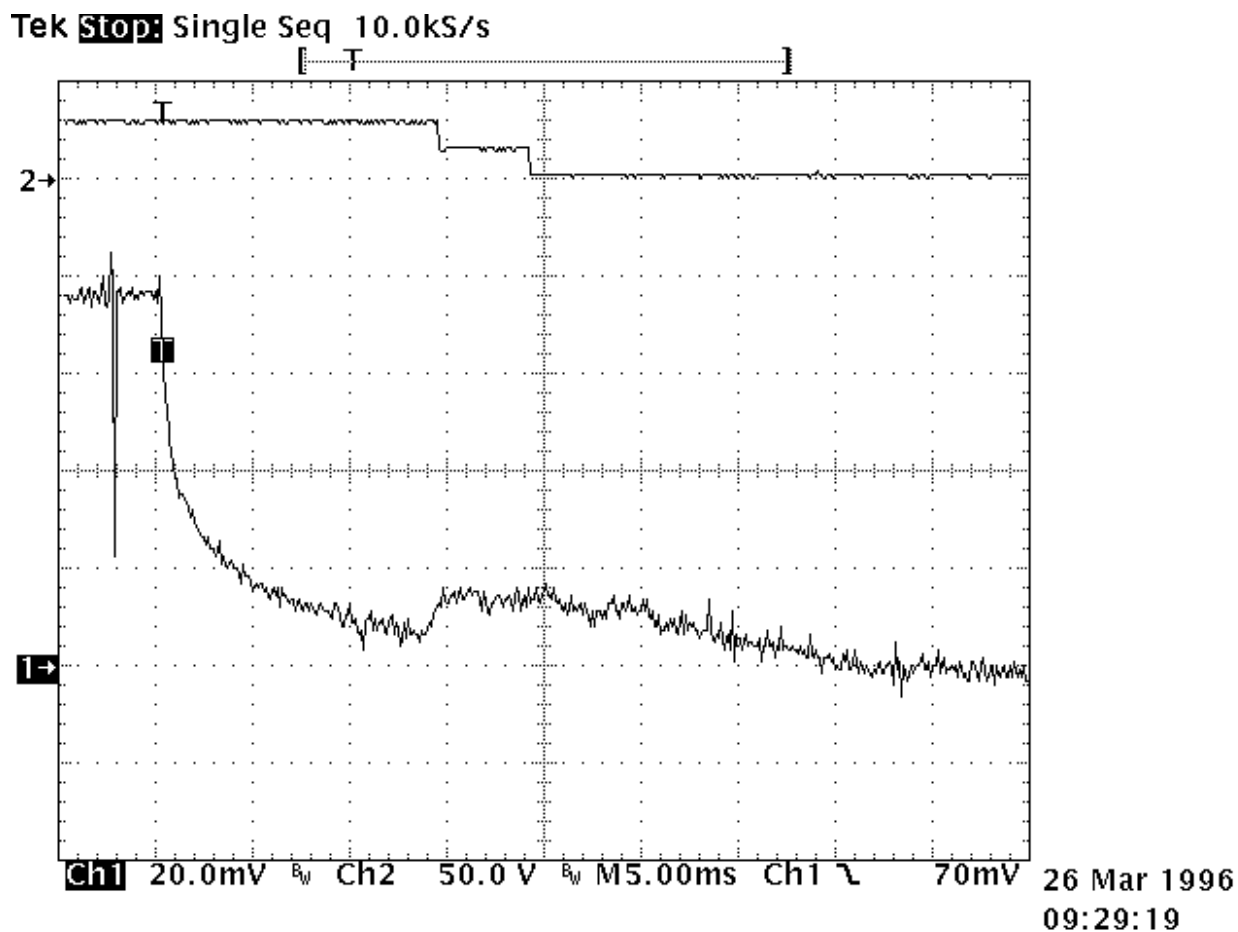

The diode + resistor network

It eliminates the inconvenience of the resistor alone, explained above, and it limits the action of a single diode. It is now preferred to use the diode + zener network.

The diode + zener network

Like the resistor, the zener allows a faster decurrent decay. In addition it introduces a threshold level for current conduction which avoids the recycling of energy released during contact movement.

The lower curve on the opposite record demonstrates those characteristics. Voltage limitation occurs at 42V. The two voltage spikes generated by internal movement are at lower levels than zener conduction. As a result, no current is recycled in the coil.

The opening time phases are as follows:

- time to start the movement 2.6ms
- total motion time 2.4ms
- transfer time 1.4ms

The release time is slightly increased. The contacts' opening speed remains unchanged.

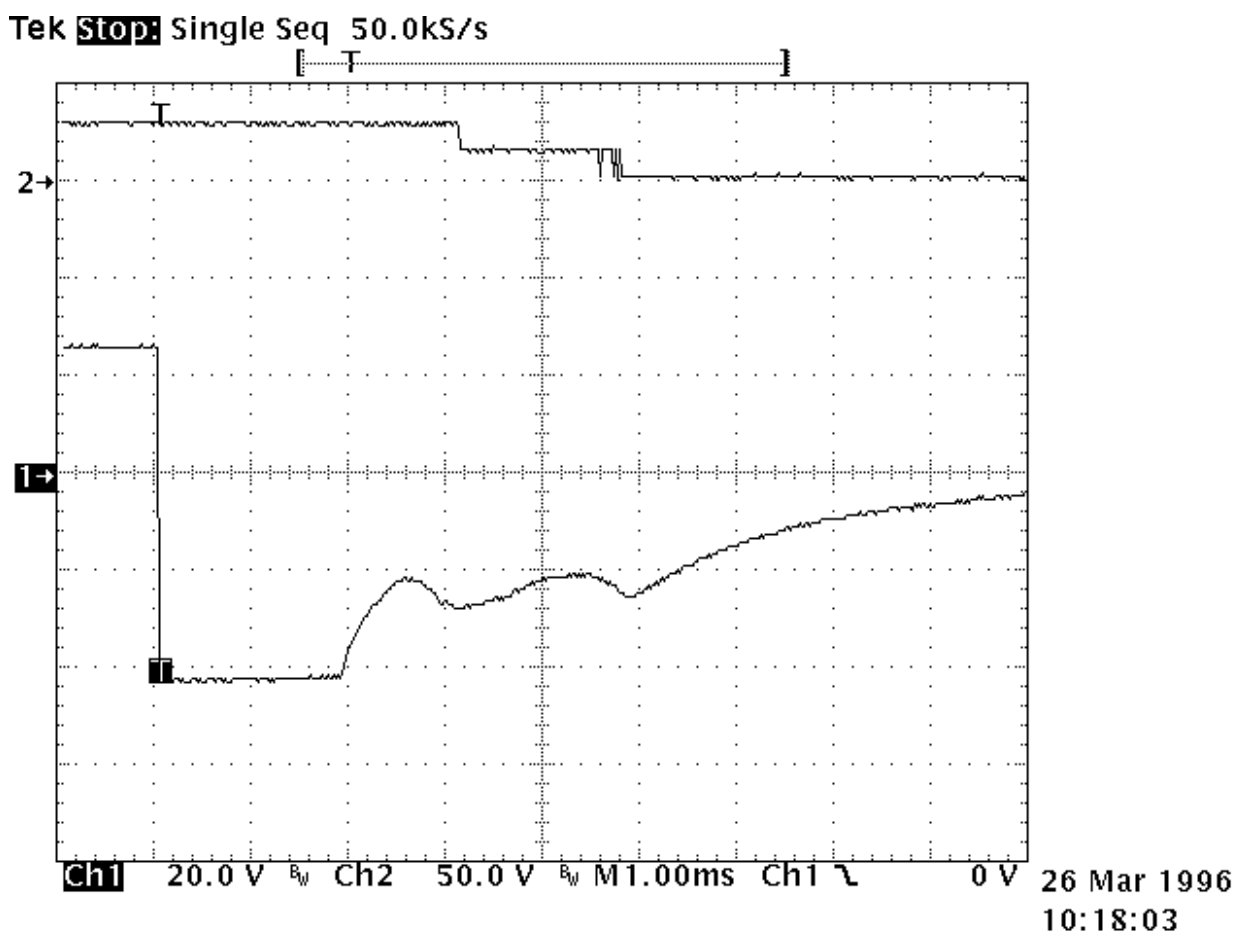

MOUNTING DISTANCE BETWEEN RELAYS
Applicable to M2XX / M3XX / M4XX / M5XX

Definition and applicability

This application note defines the minimum distance between relays to maintain the whole performances of the relays as given in our data sheets.

Phenomenon analysis

Each relay generates a magnetic field either when relay is de-energised because of the permanent magnet or in the energised position because of permanent magnet and coil. The magnetic field generated by one relay could affect the performance of another relay when the below minimum distance between relay is not respected. If the relays are mounted adjacent to each other, it is advisable to alternate direction of magnetic path on every other unit and to keep a 1.6 mm space between relays, figure "A". Or when mounted in the same direction, separate each relay from the other by 3.2 mm, figure "B". If two or more rows of relays are installed, allow clearance of 3.2 mm between rows, figures "C" and "D". Provide 4.8 mm space between relays if used in opposition, figure "E". Distance in millimetre.

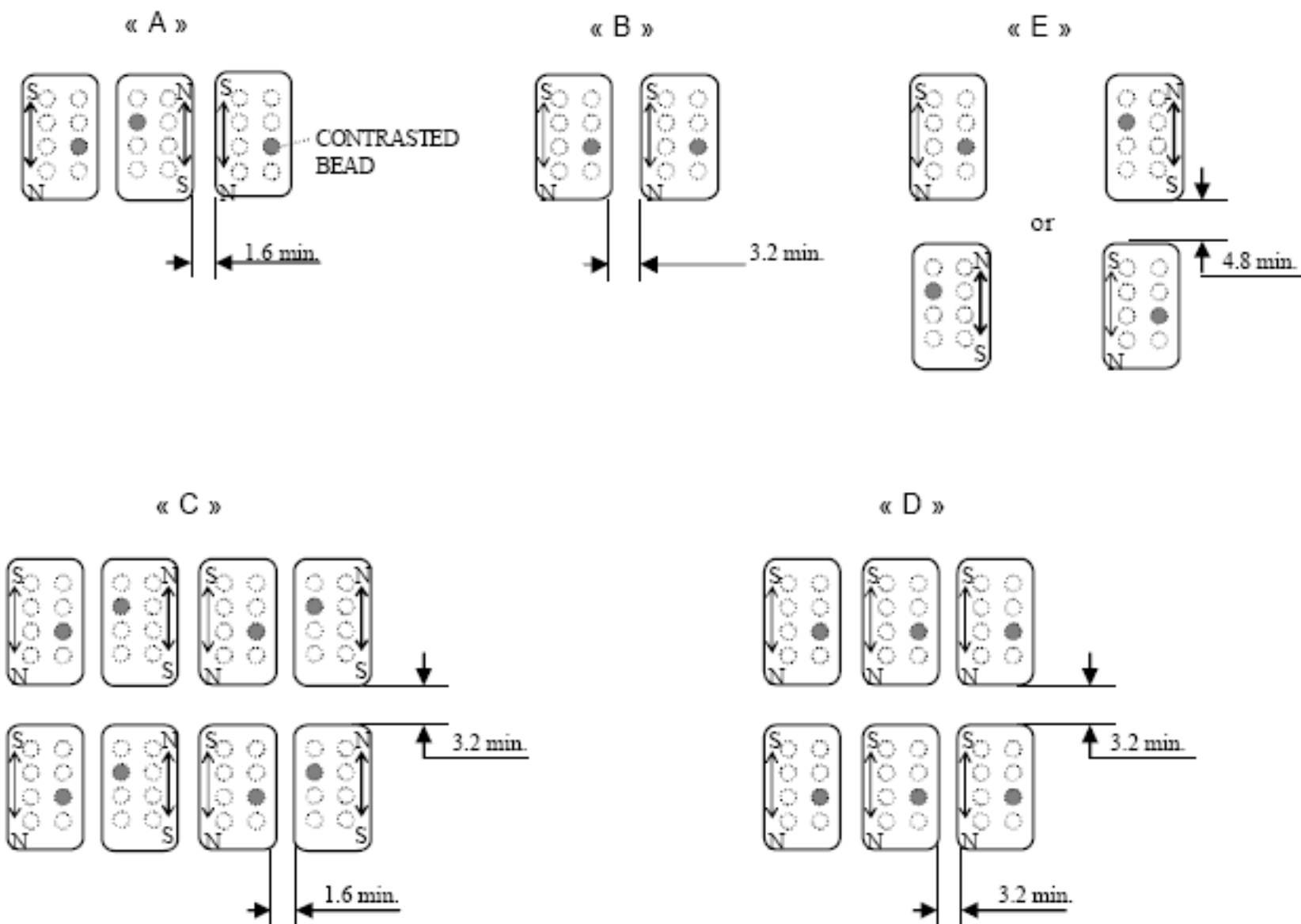

S500, S501, S502, S550

ENGINEERING DATA SHEET

RELAY SOCKET
25 AMP



BASIC SOCKET SERIES DESIGNATION FOR:

**SERIES M500 (DC Coil), M501 (AC Coil),
M502 (DC Coil), M550 (DC Coil), T531, CS500**

DESIGNED TO THE STANDARDS AND REQUIREMENTS OF:

MIL-PRF-12883/48 & /54

DIMENSIONS

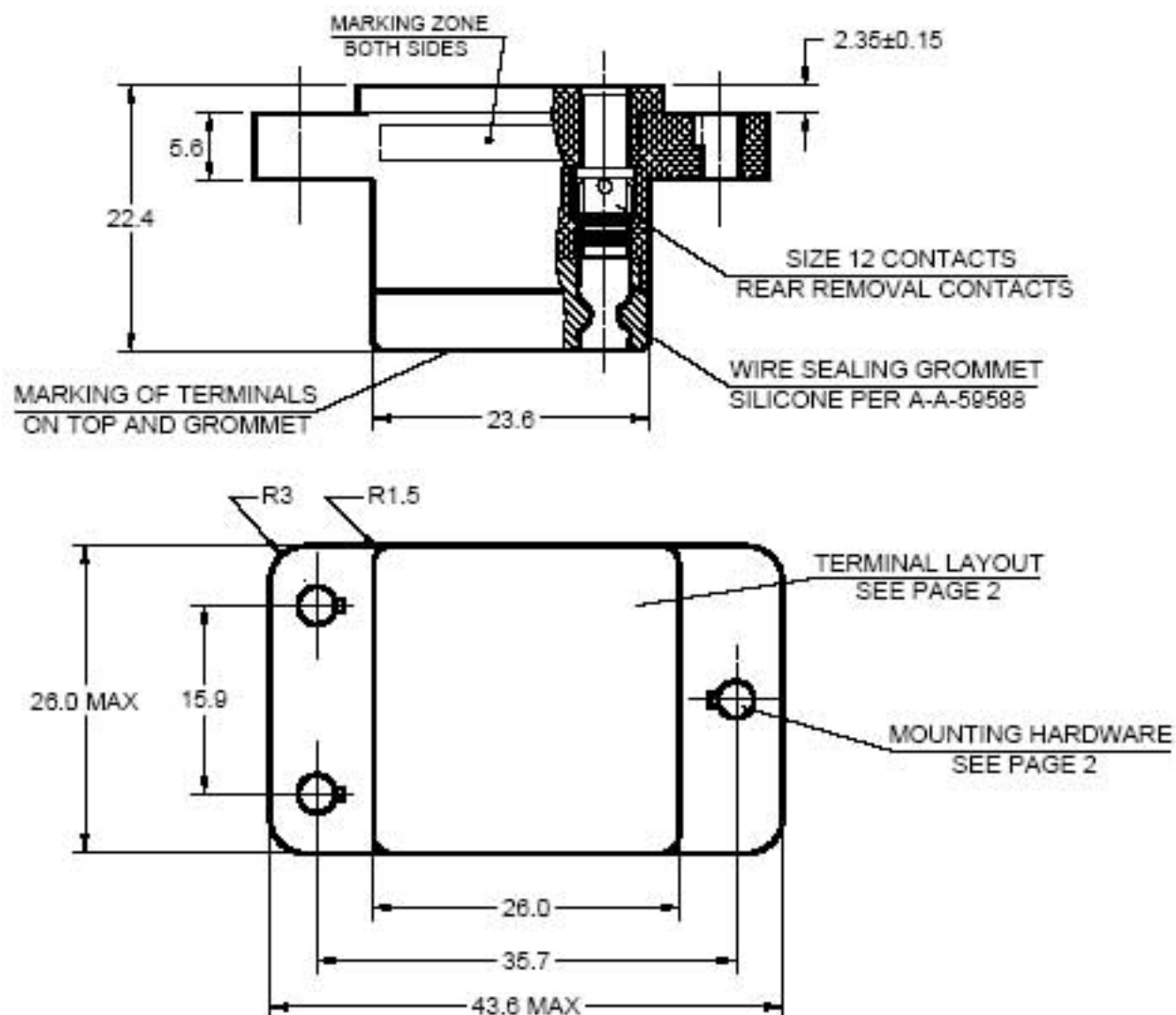

GENERAL CHARACTERISTICS

Crimp tool for contacts	M 22520/1-01, Positioner M22520/1-02
Insertion / removal tool	#16: M81969/14-03 #12: M81969/14-04
Weight	45 grams Max
Temperature range	-70°C to +125°C
Contact and mounting hardware supplied in a separate plastic bag. Standard tolerances, ±0.25mm	



Featuring **LEACH**® power and control solutions

www.leachintl.com

Data sheets are for initial product selection and comparison. Contact Leach International prior to choosing a component.

AMERICAS
6900 Orangethorpe Ave.
P.O. Box 5032
Buena Park, CA 90622 USA

Tel: (01) 714-736-7599
Fax: (01) 714-670-1145

EUROPE
2 Rue Goethe
57430 Sarralbe
France

Tel: (33) 3 87 97 31 01
Fax: (33) 3 87 97 96 86

ASIA
Room 501, 5/F, The Centre Mark
287 - 299 Queen's Road Central
Hong Kong

Tel: (852) 2 191 3830
Fax: (852) 2 389 5803

TERMINAL LAYOUT

S500, S501, S502

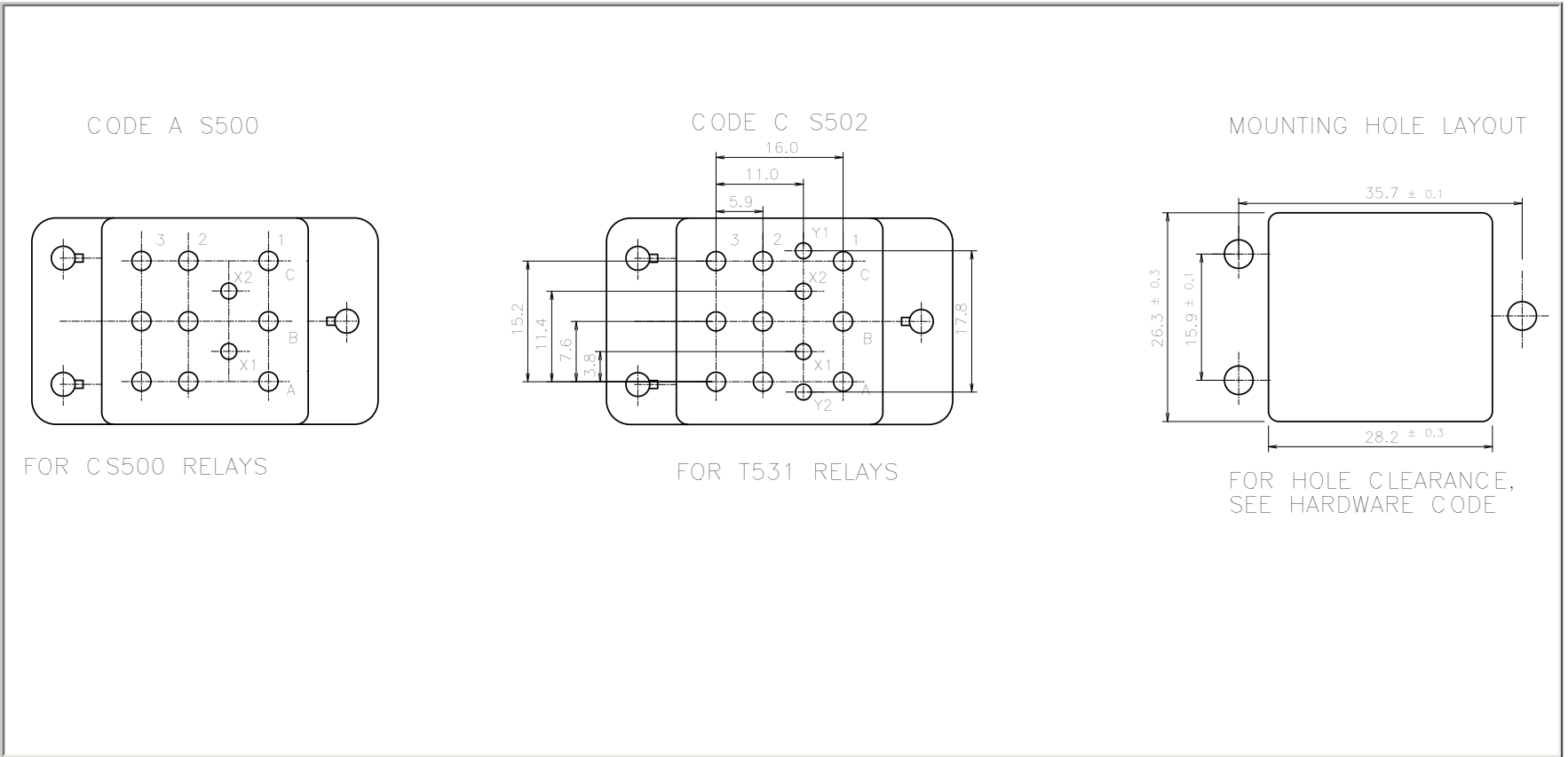

MOUNTING HARDWARE

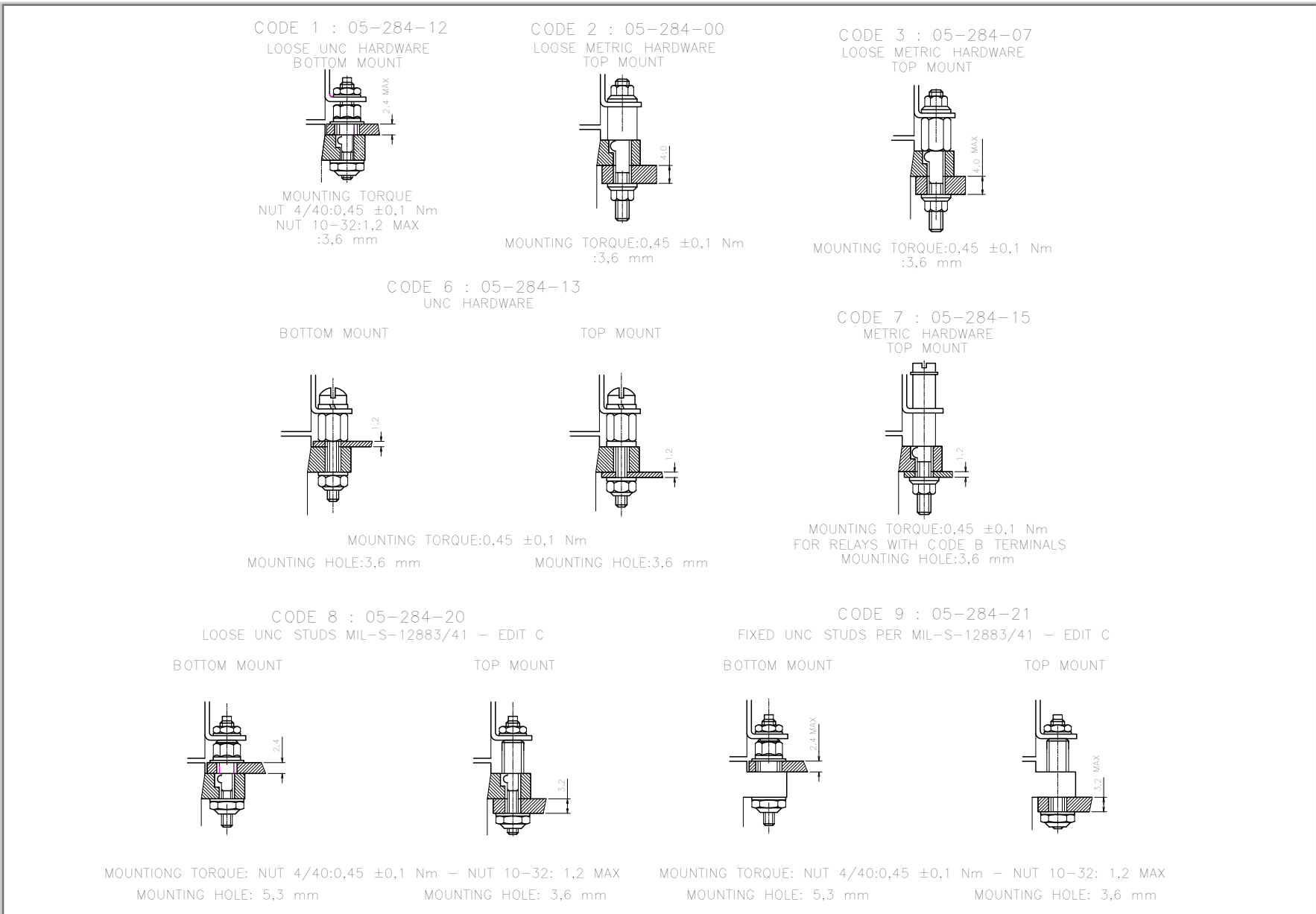

Code A	Dia: 2.83.4mm
--------	---------------------

CONTACT SIZE AND STYLE

Y1 - Y2 Crimp end to accommodate AWG 20-20-24 05 913 00 (for contact code 8 +10) <u>Contact mating end #20</u>	Code 8 Crimp end to accommodate AWG12-14 <u>Contact mating end #12</u>	Code 10 Crimp end to accommodate AWG16 <u>Contact mating end #12</u>
31 236 00 (for contact code 11 + 13) MIL-C-3902/92-532 Bin Code color bands or Bin Code numbering on crimpside <u>Contact mating end #20</u>	Coil contacts X1-X2 Crimp end to accommodate AWG16-18-20 <u>Contact mating end #16</u>	Coil contacts X1-X2 Crimp end to accommodate AWG16-18-20 <u>Contact mating end #16</u>
Code 0 Without contacts	Code 11 MIL-C-39029/92-535 30 976 00 Bin Code color bands or Bin Code numbering on crimpside Crimp end to accommodate AWG 12 <u>Contact mating end #12</u>	Code 13 MIL-C-39029/92-536 31 099 00 Bin Code color bands or Bin Code numbering on crimpside Crimp end to accommodate AWG 16 <u>Contact mating end #12</u>
	Coil contacts MIL-C-39029/92-533 X1-X2 Bin Code color bands or Bin Code numbering on crimpside Crimp end to accommodate AWG16-18-20 <u>Contact mating end #16</u>	Coil contacts MIL-C-39029/92-533 X1-X2 Bin Code color bands or Bin Code numbering on crimpside Crimp end to accommodate AWG16-18-20 <u>Contact mating end #16</u>

SOCKET NUMBERING SYSTEM

S500, S501, S502

	S500	A	1	A	8
1-Basic socket designation_____					
2-Terminal Layout_____					
3-Mounting Hardware_____					
4-Grommet to seal on wire insulation_____					
5-Contact size and style_____					

MS/LEACH CROSS PART NO. AND MATING RELAYS

	MS - Number	LEACH P/N	Number Of Contacts	Hardware
MIL-S-12883/48A	-01	S500-A8A11	9xMIL-C-39029/92-535 2xMIL-C-39029/92-533	Loose Stud
	-02	S500-A9A11	9xMIL-C-39029/92-535 2xMIL-C-39029/92-533	Fixed Stud
	-05	S501-E8A11	9xMIL-C-39029/92-535 2xMIL-C-39029/92-533	Loose Stud
	-03	S501-E9A11	9xMIL-C-39029/92-535 2xMIL-C-39029/92-533	Fixed Stud