

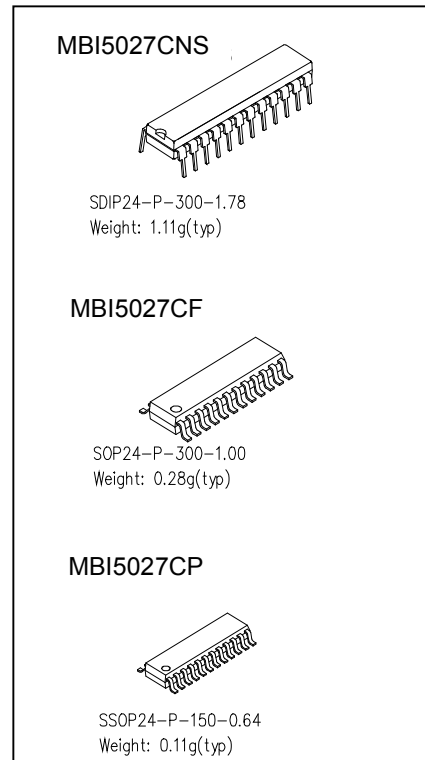

16-bit Constant Current LED Sink Driver with Error Detection

Features

- Error Detection mode to detect LED open-circuit errors
- 16 constant-current output channels
- Constant output current invariant to load voltage change
- Excellent output current accuracy:
 - between channels: $\pm 3\%$ (max.), and
 - between ICs: $\pm 6\%$ (max.)
- Output current adjusted through an external resistor
- Constant output current range: 5-90 mA
- Fast response of output current, \overline{OE} (min.): 200 ns
- 25MHz clock frequency
- Schmitt trigger input
- 5V supply voltage



Current Accuracy		Conditions
Between Channels	Between ICs	
< $\pm 3\%$	< $\pm 6\%$	$I_{OUT} = 10 \text{ mA} \sim 60 \text{ mA}$

Product Description

MBI5027 succeeds MBI5026 and is designed for LED displays with open-circuit Error Detection extension. MBI5027 exploits PrecisionDrive™ technology to enhance its output characteristics. MBI5027 contains a serial buffer and data latches, which convert serial input data into parallel output format. At MBI5027 output stage, sixteen regulated current ports are designed to provide uniform and constant current sinks for driving LEDs within a wide range of Vf variations.

While MBI5027 is used in their system design for LED display applications, e.g. LED panels, it provides users with great flexibility and device performance. Users may adjust the output current from 5 mA to 90 mA through an external resistor, R_{ext}, which gives users flexibility in controlling the light intensity of LEDs. MBI5027 guarantees to endure maximum 17V at the output port. The high clock frequency, 25 MHz, also satisfies the system requirements of high volume data transmission.

MBI5027 exploits the idea of Share-I-O™ technology to extend its performance ; in addition, MBI5027 is backward compatible with MBI5026 in both electrical characteristics and package aspect. With Share-I-O™ technology, users can, without changing the printed circuit board originally for MBI5026, let MBI5027 enter a special function mode, an Error Detection mode, just by setting a sequence of signals on LE(ED1), \overline{OE} (ED2) and CLK input pins. In the Error Detection mode, MBI5027 detects the status of individual LED connected to MBI5027. The status will be saved in a built-in register. Then, a system controller may read, through SDO pin, the error status from the register to know whether LEDs are properly lit or not. By setting another sequence of signals on LE(ED1), \overline{OE} (ED2) and CLK input pins, MBI5027 may resume to a Normal mode and perform as MBI5026. In **Application Information**, users can get detailed ideas about how MBI5027 works in the Error Detection mode.

A Share-I-O™ technique is specifically applied to MBI5027. By means of the Share-I-O™ technique, an additionally effective function, Error Detection, can be added to LED drivers, however, without any extra pins. Thus, MBI5027 could be a drop-in replacement of MBI5026. The printed circuit board originally designed for MBI5026 may be also applicable for MBI5027.

For MBI5027, the pin 4, LE(ED1), and the pin 21, \overline{OE} (ED2), can be acted as different functions as follows:

Pin \ Device Name	MBI5027
Function Description of Pin 4	LE + Error Detection (ED1)
Function Description of Pin 21	\overline{OE} + Error Detection (ED2)

Block Diagram

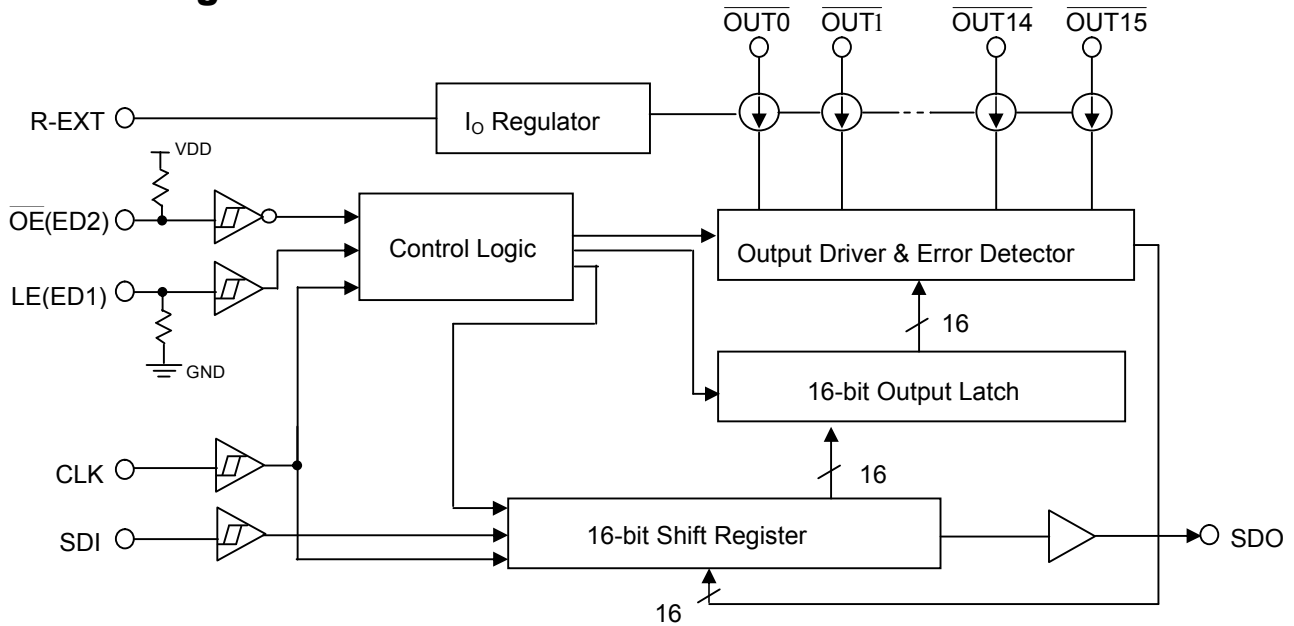

Terminal Description

Pin No.	Pin Name	Function
1	GND	Ground terminal for control logic and current sink
2	SDI	Serial-data input to the Shift Register
3	CLK	Clock input terminal for data shift on rising edge
4	LE(ED1)	Data strobe input terminal Serial data is transferred to the respective latch when LE(ED1) is high. The data is latched when LE(ED1) goes low. Also, a control signal input for Error Detection mode (See Timing Diagram)
5~20	$\overline{\text{OUT0}} \sim \overline{\text{OUT15}}$	Constant current output terminals
21	$\overline{\text{OE}}(\text{ED2})$	Output enable terminal When (active) low, the output drivers are enabled; when high, all output drivers are turned OFF (blanked). Also, a control signal input for Error Detection mode (See Timing Diagram)
22	SDO	Serial-data output to the following SDI of next driver IC
23	R-EXT	Input terminal used to connect an external resistor for setting up all output current
24	VDD	5V supply voltage terminal

Pin Configuration

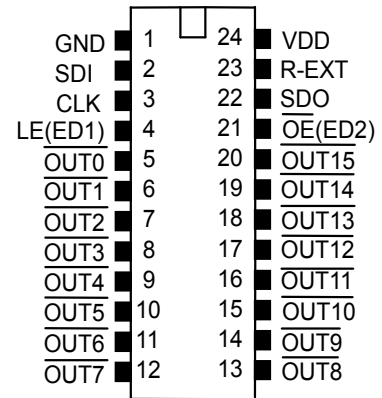

Equivalent Circuits of Inputs and Outputs

OE(ED2) terminal

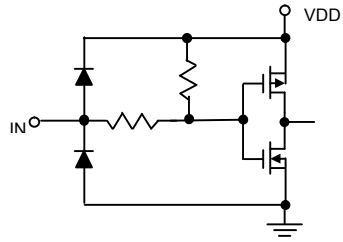

LE(ED1) terminal

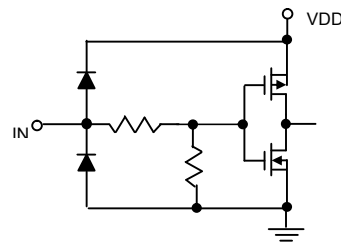

CLK, SDI terminal

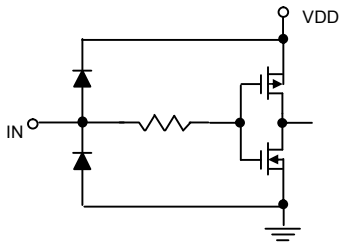

SDO terminal

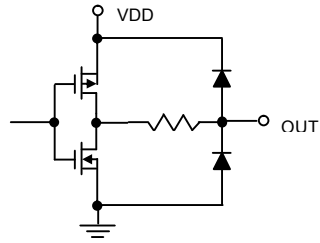

Timing Diagram

Normal Mode

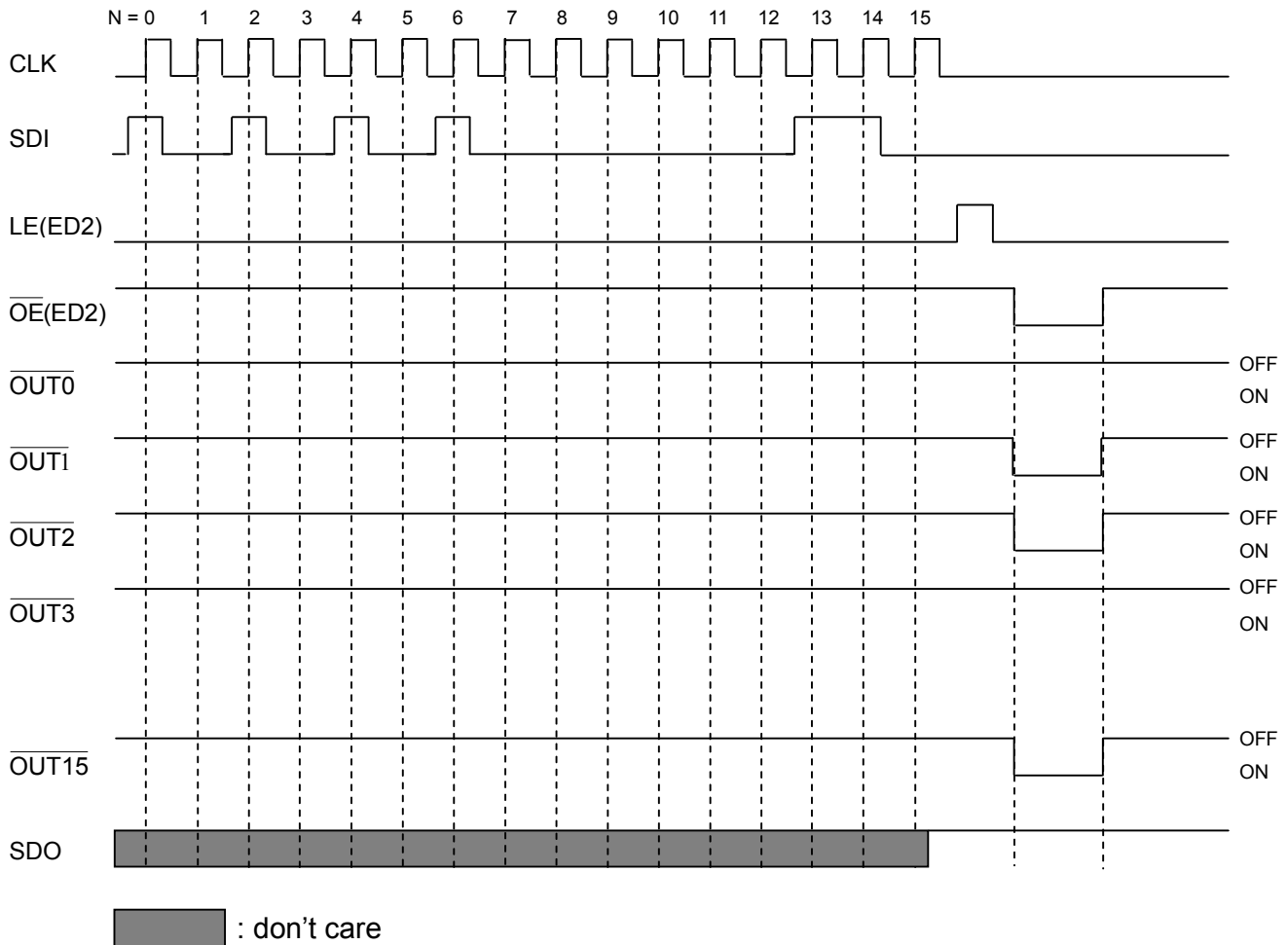

Truth Table (In Normal Mode)

CLK	LE	OE	SDI	OUT0...OUT7...OUT15	SDO
\uparrow	H	L	D_n	$\overline{D_n} \dots \overline{D_{n-7}} \dots \overline{D_{n-15}}$	D_{n-15}
\uparrow	L	L	D_{n+1}	No Change	D_{n-14}
\uparrow	H	L	D_{n+2}	$\overline{D_{n+2}} \dots \overline{D_{n-5}} \dots \overline{D_{n-13}}$	D_{n-13}
\downarrow	X	L	D_{n+3}	$\overline{D_{n+2}} \dots \overline{D_{n-5}} \dots \overline{D_{n-13}}$	D_{n-13}
\downarrow	X	H	D_{n+3}	Off	D_{n-13}

Entering Error Detection Mode

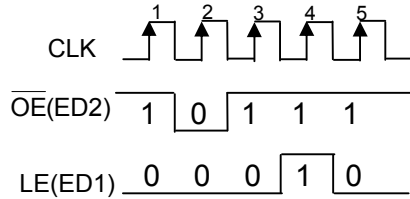

The signal sequence makes MBI5027 enter an Error Detection mode.

Reading Error Status Code

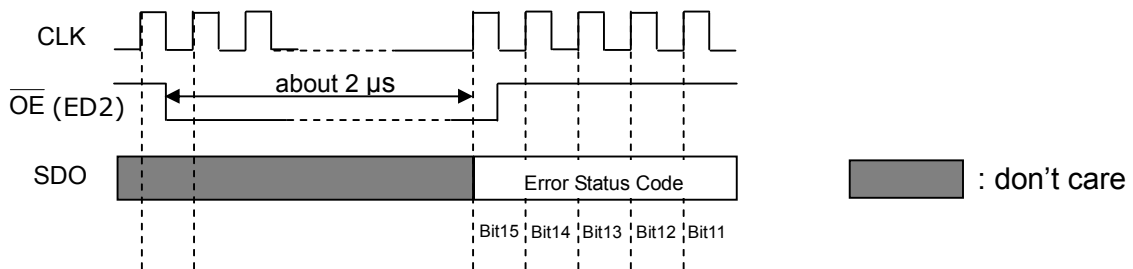

A system controller can read Error Status codes through SDO pin.

Resuming to Normal Mode

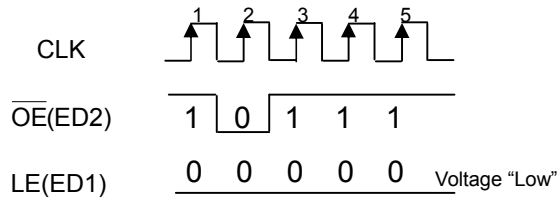

The signal sequence makes MBI5027 resume to the Normal mode.

Note:

If users want to know the whole process, that is how to enter the Error Detection mode, read Error Status codes and resume to the Normal mode, please refer to the contents in **Application Information**.

Maximum Ratings

Characteristic		Symbol	Rating	Unit
Supply Voltage		V_{DD}	0~7.0	V
Input Voltage		V_{IN}	$-0.4 \sim V_{DD} + 0.4$	V
Output Current		I_{OUT}	+90	mA
Output Voltage		V_{DS}	-0.5~+20.0	V
Clock Frequency		F_{CLK}	25	MHz
GND Terminal Current		I_{GND}	1440	mA
Power Dissipation (On PCB, $T_a=25^\circ\text{C}$)	CNS – type	P_D	1.52	W
	CF – type		1.30	
	CP – type		1.11	
Thermal Resistance (On PCB, $T_a=25^\circ\text{C}$)	CNS – type	$R_{th(j-a)}$	82	$^\circ\text{C/W}$
	CF – type		96	
	CP – type		112	
Operating Temperature		T_{opr}	-40~+85	$^\circ\text{C}$
Storage Temperature		T_{stg}	-55~+150	$^\circ\text{C}$

Recommended Operating Conditions

Characteristic	Symbol	Condition	Min.	Typ.	Max.	Unit
Supply Voltage	V _{DD}	-	4.5	5.0	5.5	V
Output Voltage	V _{DS}	$\overline{\text{OUT0}} \sim \overline{\text{OUT15}}$	-	-	17.0	V
Output Current	I _{OUT}	DC Test Circuit	5	-	60	mA
	I _{OH}	SDO	-	-	-1.0	mA
	I _{OL}	SDO	-	-	1.0	mA
Input Voltage	V _{IH}	CLK, $\overline{\text{OE}}$ (ED2), LE(ED1) and SDI	0.8V _{DD}	-	V _{DD} +0.3	V
	V _{IL}	CLK, $\overline{\text{OE}}$ (ED2), LE(ED1) and SDI	-0.3	-	0.3V _{DD}	V
LE(ED1) Pulse Width	t _{w(L)}	Normal Mode V _{DD} =4.5~5.5V	40	-	-	ns
CLK Pulse Width	t _{w(CLK)}		20	-	-	ns
$\overline{\text{OE}}$ (ED2) Pulse Width	t _{w(OE)}		200	-	-	ns
Setup Time for SDI	t _{su(D)}		5	-	-	ns
Hold Time for SDI	t _{h(D)}		10	-	-	ns
Setup Time for LE(ED1)	t _{su(L)}		15	-	-	ns
Hold Time for LE(ED1)	t _{h(L)}		15	-	-	ns
$\overline{\text{OE}}$ (ED2) Pulse Width	t _{w(ED2)}	Error Detection Mode V _{DD} =4.5~5.5V	2	-	-	us
CLK Pulse Width	t _{w(CLK)}		20	-	-	ns
Setup Time for LE(ED1)	t _{su(ED1)}		5	-	-	ns
Hold Time for LE(ED1)	t _{h(ED1)}		10	-	-	ns
Setup Time for $\overline{\text{OE}}$ (ED2)	t _{su(ED2)}		5	-	-	ns
Hold Time for $\overline{\text{OE}}$ (ED2)	t _{h(ED2)}		10	-	-	ns
Clock Frequency	F _{CLK}	Cascade Operation	-	-	25.0	MHz
Power Dissipation	P _D	Ta=85°C (CNS type)	-	-	0.79	W
		Ta=85°C (CF type)	-	-	0.67	
		Ta=85°C (CP type)	-	-	0.57	

Electrical Characteristics

Characteristic		Symbol	Condition		Min.	Typ.	Max.	Unit
Input Voltage	“H” level	V_{IH}	$T_a = -40\sim 85^\circ\text{C}$		$0.8V_{DD}$	-	V_{DD}	V
	“L” level	V_{IL}	$T_a = -40\sim 85^\circ\text{C}$		GND	-	$0.3V_{DD}$	V
Output Leakage Current		I_{OH}	$V_{OH}=17.0\text{V}$		-	-	0.5	μA
Output Voltage	SDO	V_{OL}	$I_{OL}=+1.0\text{mA}$		-	-	0.4	V
		V_{OH}	$I_{OH}=-1.0\text{mA}$		4.6	-	-	V
Output Current 1		I_{OUT1}	$V_{DS}=0.6\text{V}$	$R_{ext}=720\ \Omega$	-	25.0	-	mA
Current Skew		dI_{OUT1}	$I_{OL}=25\text{mA}$ $V_{DS}=0.6\text{V}$	$R_{ext}=720\ \Omega$	-	± 1	± 3	%
Output Current 2		I_{OUT2}	$V_{DS}=0.8\text{V}$	$R_{ext}=360\ \Omega$	-	50.0	-	mA
Current Skew		dI_{OUT2}	$I_{OL}=50\text{mA}$ $V_{DS}=0.8\text{V}$	$R_{ext}=360\ \Omega$	-	± 1	± 3	%
Output Current vs. Output Voltage Regulation		$\%/dV_{DS}$	V_{DS} within 1.0V and 3.0V		-	± 0.1	-	% / V
Output Current vs. Supply Voltage Regulation		$\%/dV_{DD}$	V_{DD} within 4.5V and 5.5V		-	± 1	-	% / V
Pull-up Resistor		$R_{IN(up)}$	$\overline{\text{OE}}$ (ED2)		250	500	800	K Ω
Pull-down Resistor		$R_{IN(down)}$	LE(ED1)		250	500	800	K Ω
Open Circuit Error*** Discrimination Voltage		$V_{DS, Th1}$	When all output ports sink 20mA simultaneously		1.0	-	-	V
		$V_{DS, Th2}$	When a single output port sinks 20mA		0.8	-	-	V
		$V_{DS, Th3}$	When all output ports sink 50mA simultaneously		1.2	-	-	V
		$V_{DS, Th4}$	When a single output port sinks 50mA		1.0	-	-	V
Supply Current	“OFF”	$I_{DD(off) 1}$	$R_{ext}=\text{Open}$, $\overline{\text{OUT0}} \sim \overline{\text{OUT15}} =\text{Off}$		-	9	-	mA
		$I_{DD(off) 2}$	$R_{ext}=720\ \Omega$, $\overline{\text{OUT0}} \sim \overline{\text{OUT15}} =\text{Off}$		-	11	-	
		$I_{DD(off) 3}$	$R_{ext}=360\ \Omega$, $\overline{\text{OUT0}} \sim \overline{\text{OUT15}} =\text{Off}$		-	14	-	
	“ON”	$I_{DD(on) 1}$	$R_{ext}=720\ \Omega$, $\overline{\text{OUT0}} \sim \overline{\text{OUT15}} =\text{On}$		-	11	-	
		$I_{DD(on) 2}$	$R_{ext}=360\ \Omega$, $\overline{\text{OUT0}} \sim \overline{\text{OUT15}} =\text{On}$		-	14	-	

*** To effectively detect the error occurring at the output port, MBI5027 has a built-in current detection circuit. The current detection circuit will detect the effective current $I_{OUT, effective}$, and compare the effective current $I_{OUT, effective}$ to the target current $I_{OUT, target}$, defined by R_{ext} . If $I_{OUT, effective}$ is much less than the target current $I_{OUT, target}$, an error flag will be asserted in the built-in Shift Register. The minimum voltage requirement for such current detection is $V_{DS, Th1}$, $V_{DS, Th2}$, $V_{DS, Th3}$ and $V_{DS, Th4}$.

Test Circuit for Electrical Characteristics

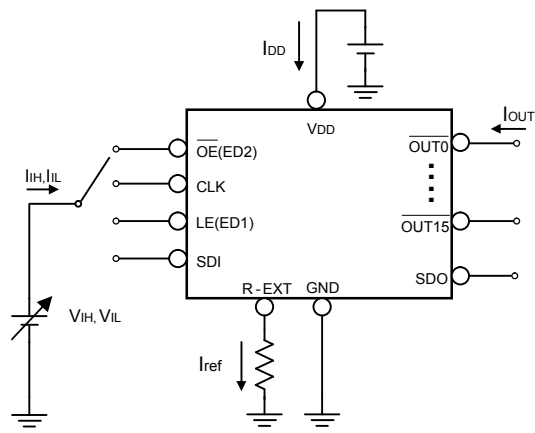

Switching Characteristics

Characteristic		Symbol	Condition	Min.	Typ.	Max.	Unit
Propagation Delay Time ("L" to "H")	CLK - $\overline{\text{OUTn}}$	t_{pLH1}	$V_{DD}=5.0\text{ V}$ $V_{DS}=0.8\text{ V}$ $V_{IH}=V_{DD}$ $V_{IL}=\text{GND}$ $R_{ext}=300\ \Omega$ $V_L=4.0\text{ V}$ $R_L=52\ \Omega$ $C_L=10\text{ pF}$	-	50	100	ns
	LE(ED1) - $\overline{\text{OUTn}}$	t_{pLH2}		-	50	100	ns
	$\overline{\text{OE}}$ (ED2) - $\overline{\text{OUTn}}$	t_{pLH3}		-	20	100	ns
Propagation Delay Time ("H" to "L")	CLK - SDO	t_{pLH}		15	20	-	ns
	CLK - $\overline{\text{OUTn}}$	t_{pHL1}		-	100	150	ns
	LE(ED1) - $\overline{\text{OUTn}}$	t_{pHL2}		-	100	150	ns
	$\overline{\text{OE}}$ (ED2) - $\overline{\text{OUTn}}$	t_{pHL3}		-	50	150	ns
Pulse Width	CLK - SDO	t_{pHL}		15	20	-	ns
	CLK	$t_{w(\text{CLK})}$		20	-	-	ns
	LE(ED1)	$t_{w(L)}$		20	-	-	ns
	$\overline{\text{OE}}$ (ED2)	$t_{w(\text{OE})}$	200	-	-	ns	
Hold Time for LE(ED1)		$t_{h(L)}$	5	-	-	ns	
Setup Time for LE(ED1)		$t_{su(L)}$	5	-	-	ns	
Maximum CLK Rise Time		t_r^{**}	-	-	500	ns	
Maximum CLK Fall Time		t_f^{**}	-	-	500	ns	
Output Rise Time of Iout		t_{or}	-	70	200	ns	
Output Fall Time of Iout		t_{of}	-	40	120	ns	

**If the devices are connected in cascade and t_r or t_f is large, it may be critical to achieve the timing required for data transfer between two cascaded devices.

Test Circuit for Switching Characteristics

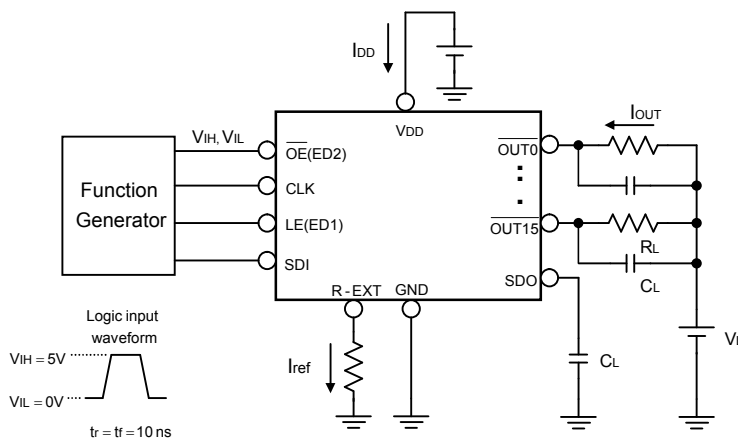

Timing Waveform

Normal Mode

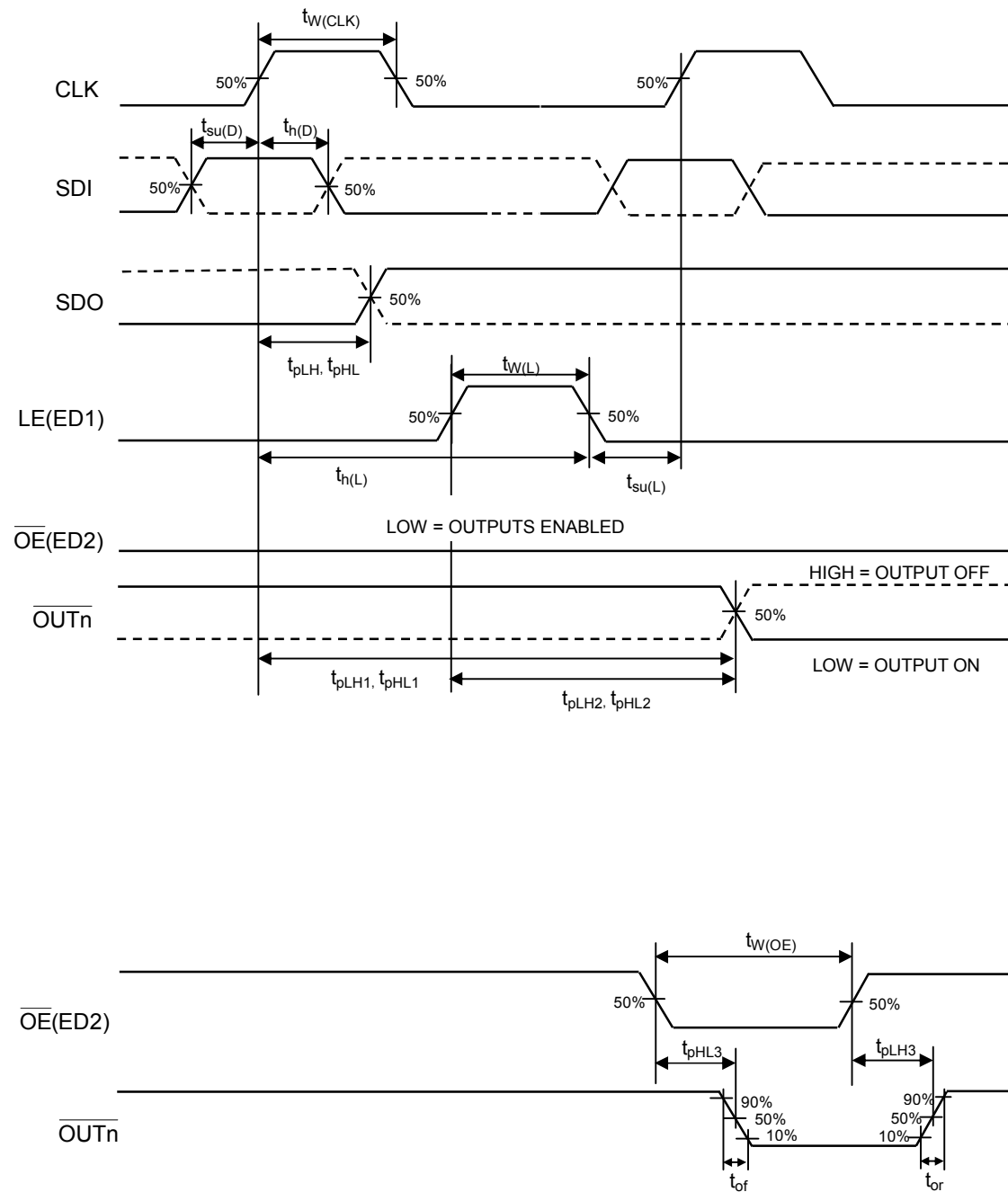

Entering Error Detection Mode

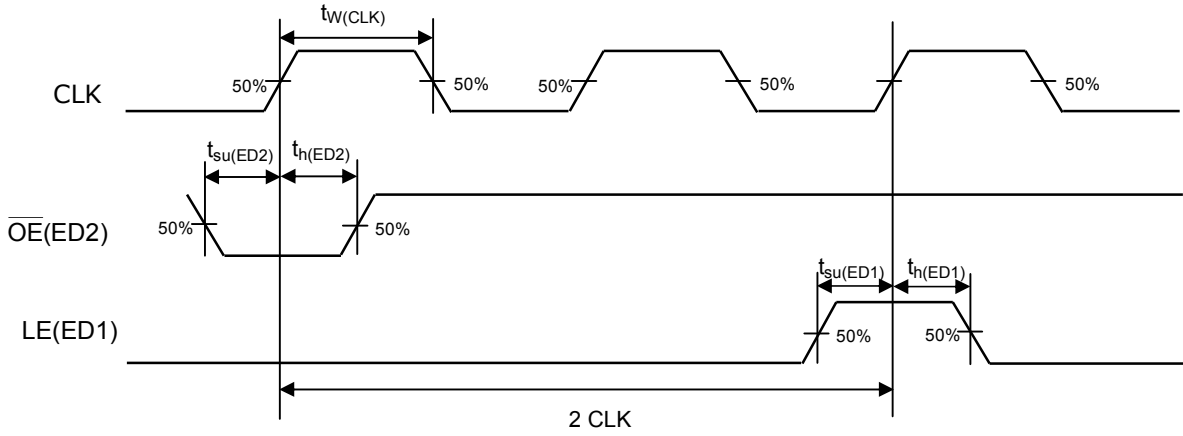

Reading Error Status Code

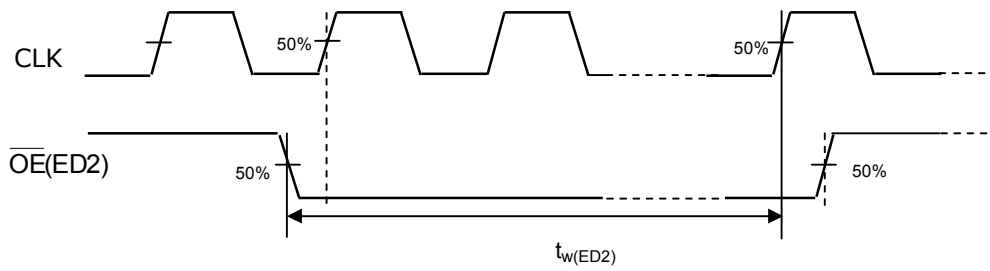

Application Information

Constant Current

To design LED displays, MBI5027 provides nearly no variations in current from channel to channel and from IC to IC. This can be achieved by:

- 1) The maximum current variation between channels is less than $\pm 3\%$ and that between ICs is less than $\pm 6\%$.
- 2) In addition, the current characteristic of output stage is flat and users can refer to the figure as shown below. The output current can be kept constant regardless of the variations of LED forward voltages (V_f). This performs as a complete function of the load regulation.

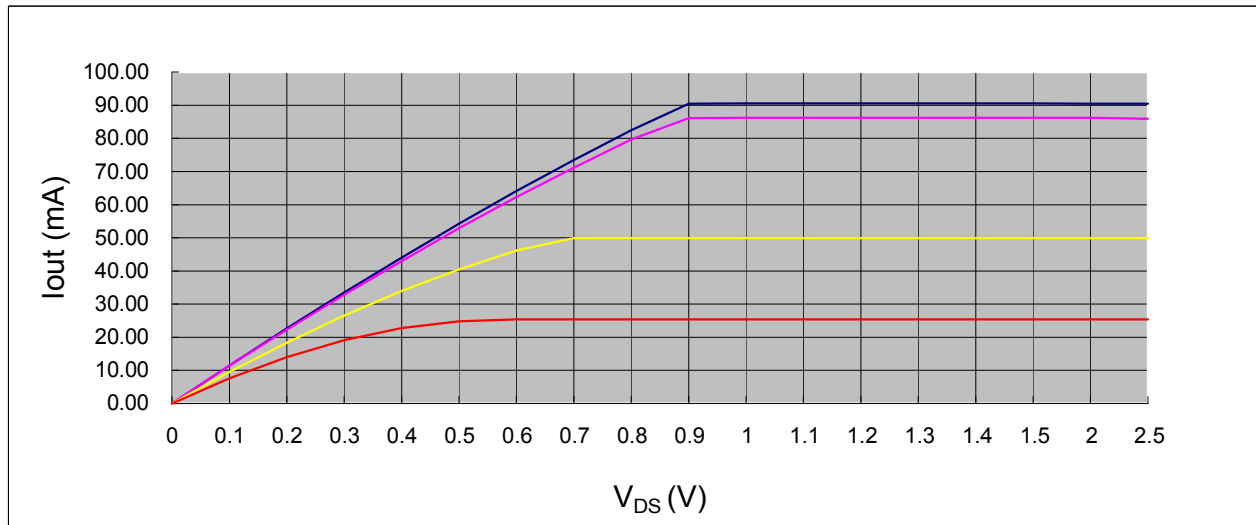

Adjusting Output Current

The output current of each channel (I_{OUT}) is set by an external resistor, R_{ext} . The relationship between I_{OUT} and R_{ext} is shown in the following figure.

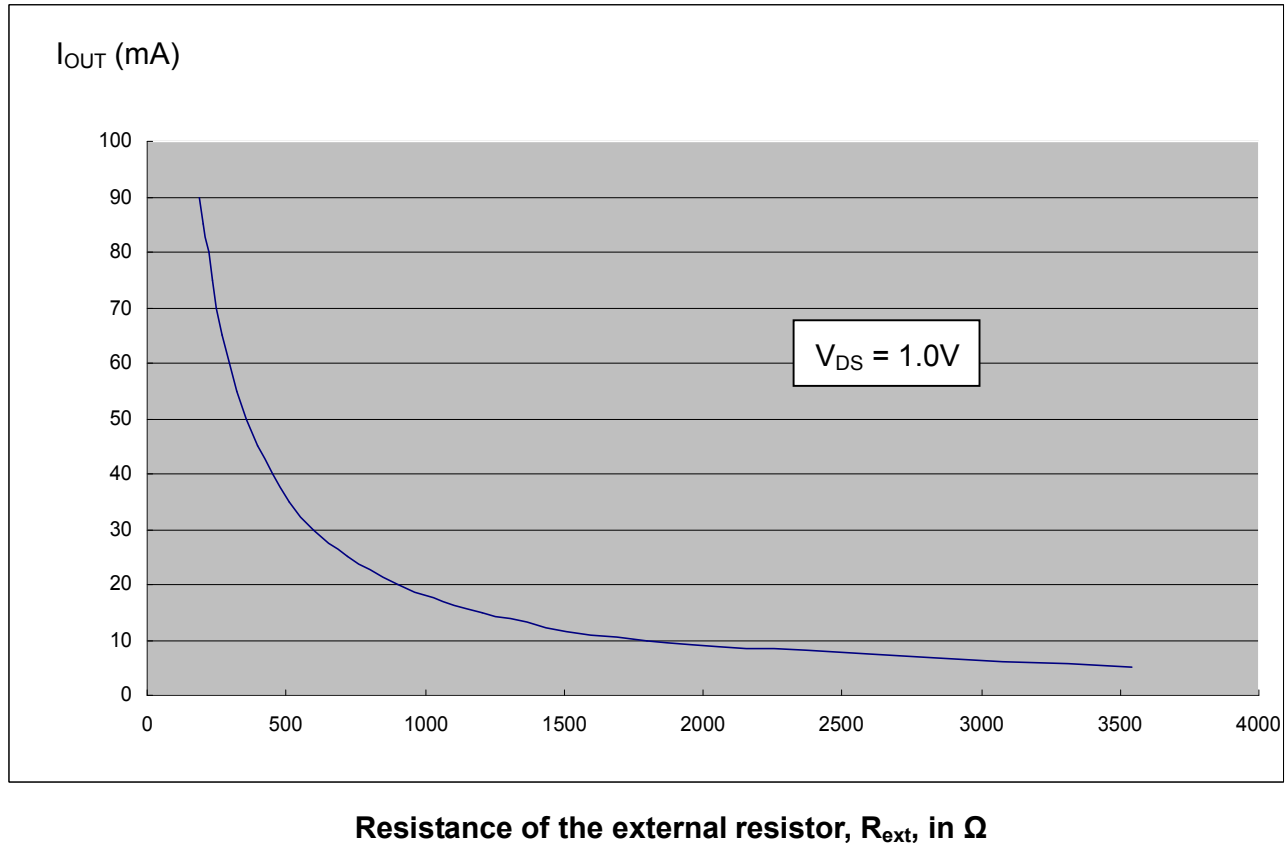

Also, the output current in milliamps can be calculated from the equation:

I_{OUT} is $(625 / R_{ext}) \times 28.8$, approximately,

where R_{ext} , in Ω , is the resistance of the external resistor connected to R-EXT terminal.

The magnitude of current is around 50mA at 360 Ω and 25mA at 720 Ω .

Entering Error Detection Mode

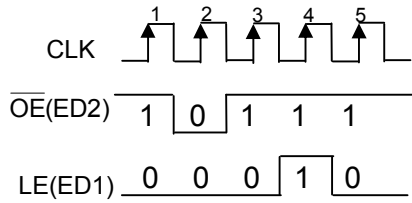

Each time the system controller sends the sequence patterns shown above, MBI5027 can enter the Error Detection mode. During this phase, the system controller can still send data through SDI pin.

The state of \overline{OE} (ED2) and LE(ED1) is sampled by the rising edge of each CLK. We use “0” and “1” to represent the state of “Voltage Low” and “Voltage High” respectively. The states of the successive five \overline{OE} (ED2) and LE(ED1) are (1, 0), (0, 0), (1, 0), (1, 1) and (1, 0).

Reading Error Status Code

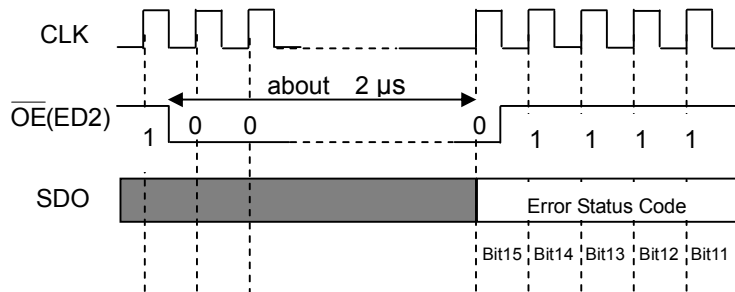

Once entering the Error Detection mode, the Error Detection takes place by changing the state of \overline{OE} (ED2) from “Voltage High” to “Voltage Low”. The built-in current detection circuit will detect the effective current $I_{OUT, effective}$ of each output channel, and compare it to the target current $I_{OUT, target}$, defined by R_{ext} . If the $I_{OUT, effective}$ is much less than the target current $I_{OUT, target}$, an error status code will be represented as “0” state. During the period of detecting errors, data cannot be sent into MBI5027 through SDI pin. The “Voltage Low” state of \overline{OE} (ED2) requires at least three “0” of which the last “0” should be at least 2 μ s after the falling edge of \overline{OE} (ED2). The occurrence of the last “0” results in the event that MBI5027 saves the error status in the built-in register. The mentioned state of each “0” is sampled by the rising edge of each CLK. Before the error status saved in the built-in register is read, the state of \overline{OE} (ED2) should be pulled up from “Voltage Low” to “Voltage High”. Then, by sending CLK, MBI5027 shifts out, through SDO pin, the error status bit by bit.

Resuming to Normal Mode

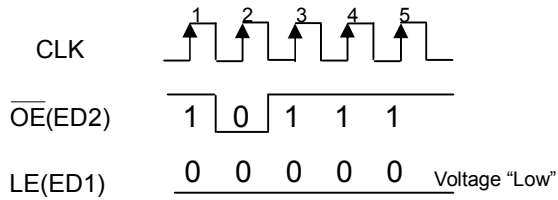

Each time the system controller sends the sequence patterns shown above, MBI5027 can resume to the Normal mode. During this phase, the system controller can still send data through SDI pin.

The state of $\overline{OE}(ED2)$ and LE(ED1) is sampled by the rising edge of each CLK. We use "0" and "1" to represent the state of "Voltage Low" and "Voltage High" respectively. The states of the successive five $\overline{OE}(ED2)$ and LE(ED1) are (1, 0), (0, 0), (1, 0), (1, 0) and (1, 0).

Timing Chart for Error Detection Mode (An Example)

N x MBI5027 are connected in cascade, ie, SDO, k → SDI, k+1.
 And, all MBI5027 ICs are connected to the same CLK, LE(ED1) and OE(ED2) signals.

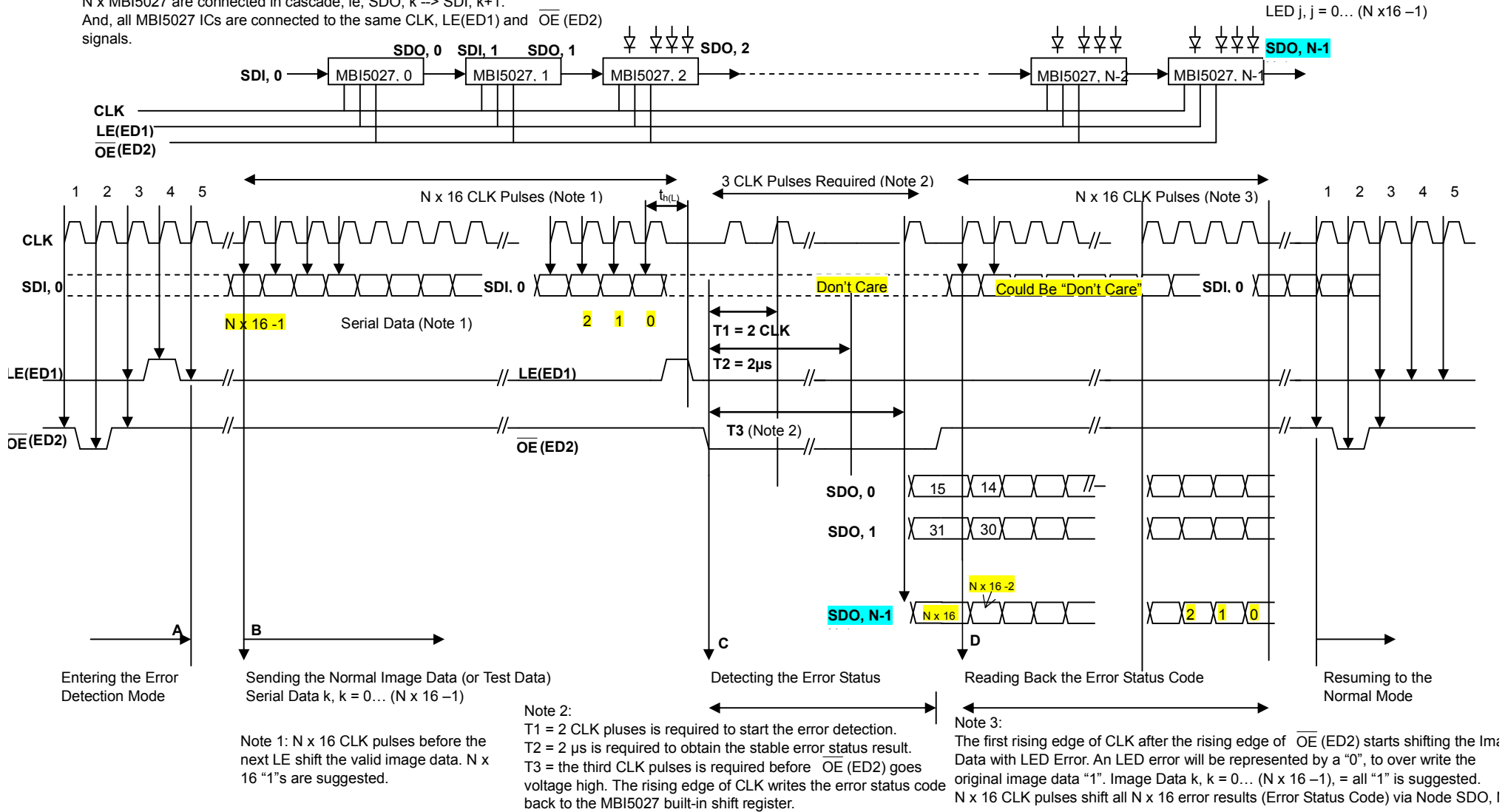

Note 1: N x 16 CLK pulses before the next LE shift the valid image data. N x 16 "1"s are suggested.

Note 2:
 T1 = 2 CLK pluses is required to start the error detection.
 T2 = 2 μs is required to obtain the stable error status result.
 T3 = the third CLK pulses is required before OE(ED2) goes voltage high. The rising edge of CLK writes the error status code back to the MBI5027 built-in shift register.

Note 3:
 The first rising edge of CLK after the rising edge of OE(ED2) starts shifting the Image Data with LED Error. An LED error will be represented by a "0", to over write the original image data "1". Image Data k, k = 0... (N x 16 - 1), = all "1" is suggested. N x 16 CLK pulses shift all N x 16 error results (Error Status Code) via Node SDO, 1

Package Power Dissipation (P_D)

The maximum allowable package power dissipation is determined as $P_D(max) = (T_j - T_a) / R_{th(j-a)}$. When 16 output channels are turned on simultaneously, the actual package power dissipation is $P_D(act) = (I_{DD} \times V_{DD}) + (I_{OUT} \times Duty \times V_{DS} \times 16)$. Therefore, to keep $P_D(act) \leq P_D(max)$, the allowable maximum output current as a function of duty cycle is:

$$I_{OUT} = \{ [(T_j - T_a) / R_{th(j-a)}] - (I_{DD} \times V_{DD}) \} / V_{DS} / Duty / 16,$$

where $T_j = 150^\circ C$.

(A) I_{out} = 90mA, V_{DS} = 1.0V, 16 output channels active

For CNS type package, the thermal resistance is $R_{th(j-a)} = 82 (^\circ C/W)$

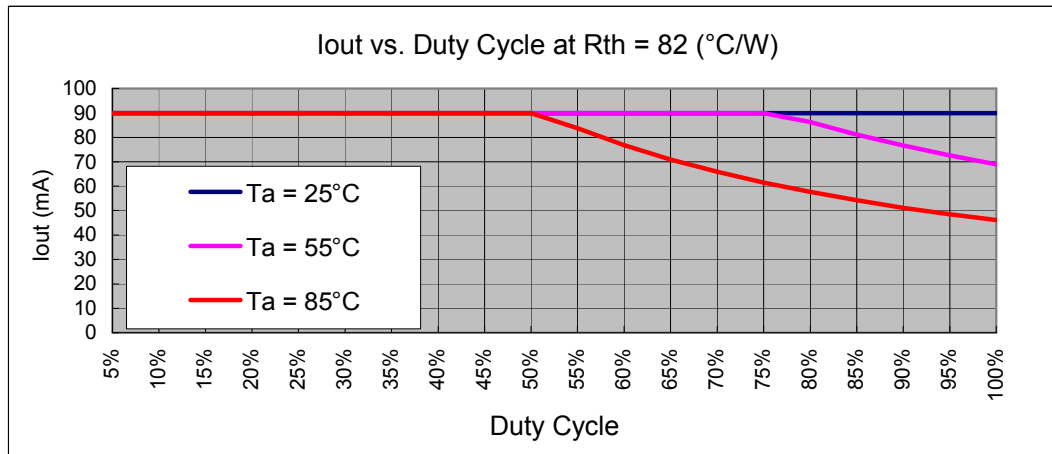

For CF type package, the thermal resistance is $R_{th(j-a)} = 96 (^\circ C/W)$

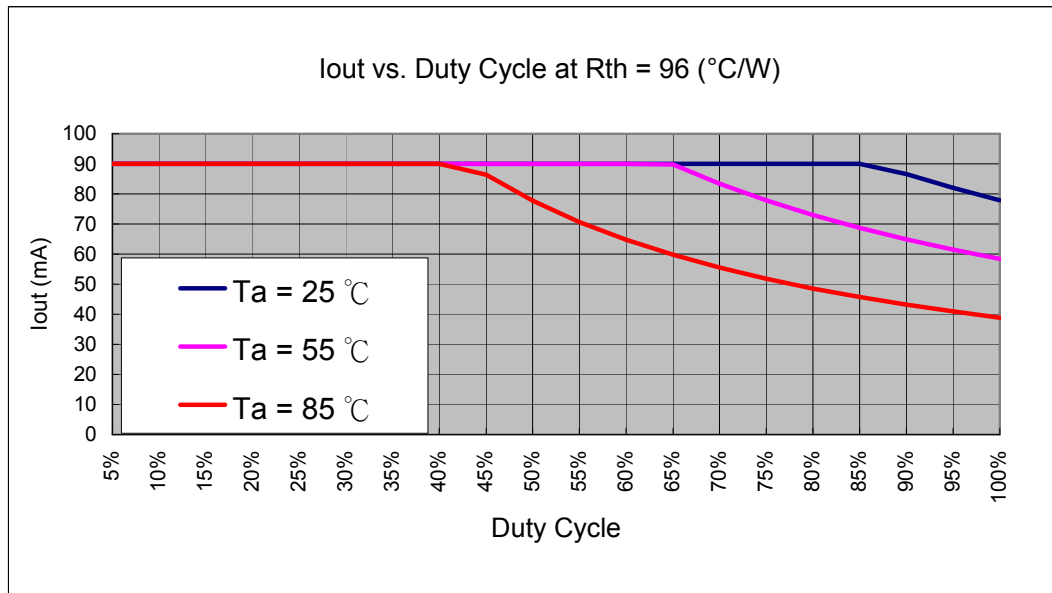

For CP type package, the thermal resistance is $R_{th(j-a)} = 112 \text{ (}^\circ\text{C/W)}$

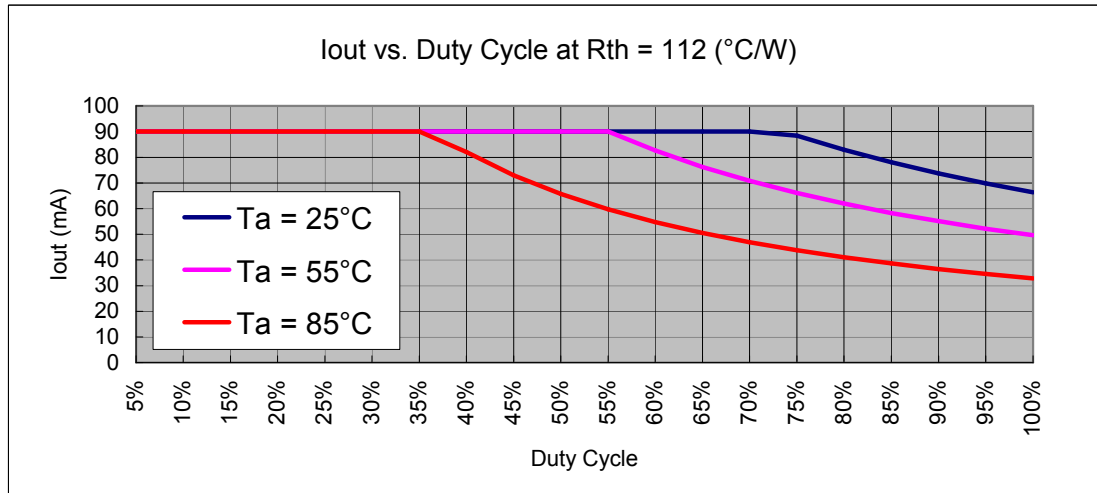

(B) $I_{out} = 60\text{mA}$, $V_{DS} = 0.8\text{V}$, 16 output channels active

For CNS type package, the thermal resistance is $R_{th(j-a)} = 82 \text{ (}^\circ\text{C/W)}$

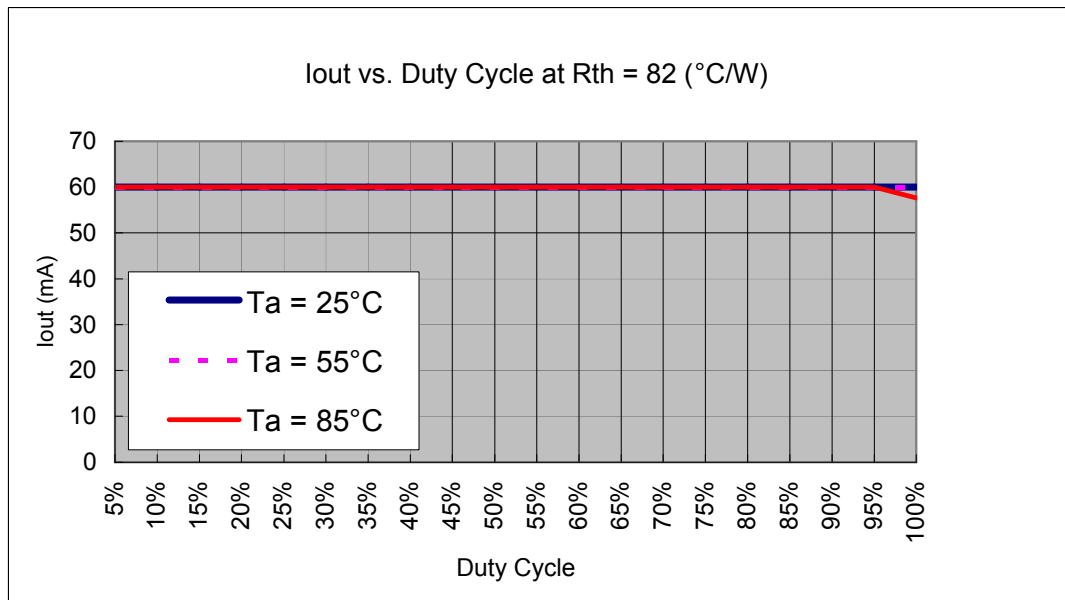

For CF type package, the thermal resistance is $R_{th(j-a)} = 96$ ($^{\circ}C/W$)

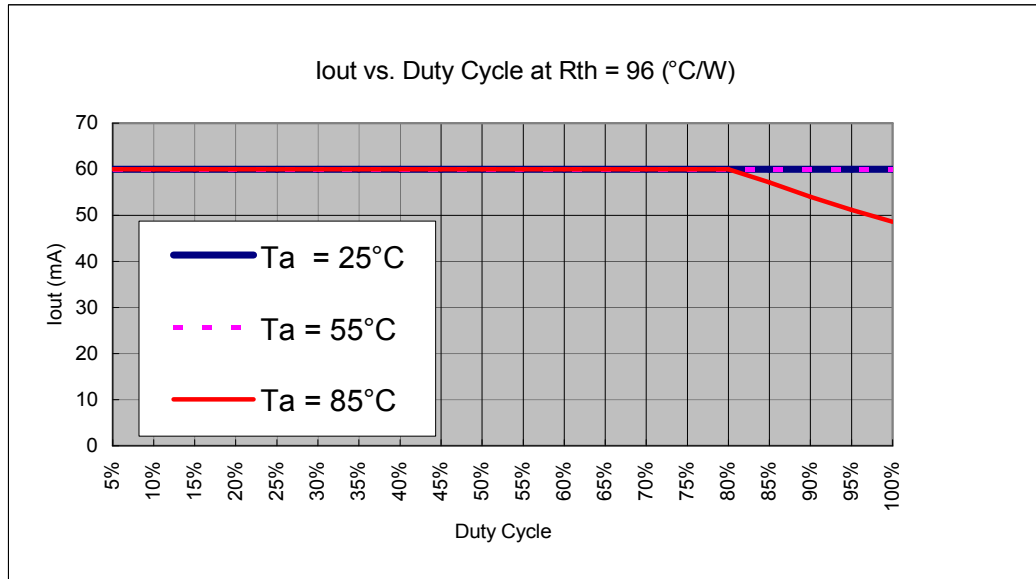

For CP type package, the thermal resistance is $R_{th(j-a)} = 112$ ($^{\circ}C/W$)

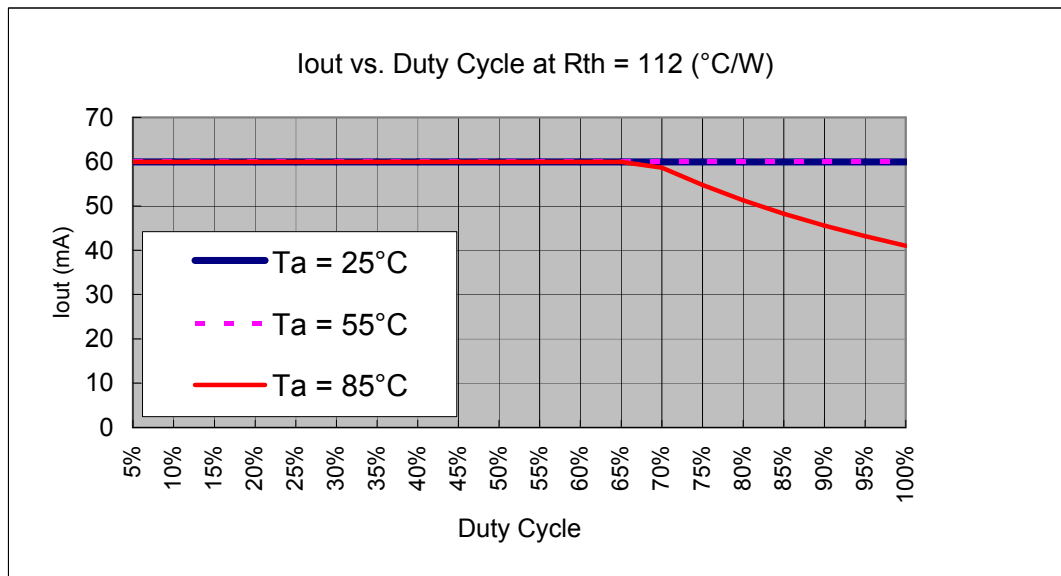

The maximum power dissipation, $P_D(\max) = (T_j - T_a) / R_{th(j-a)}$, decreases as the ambient temperature increases.

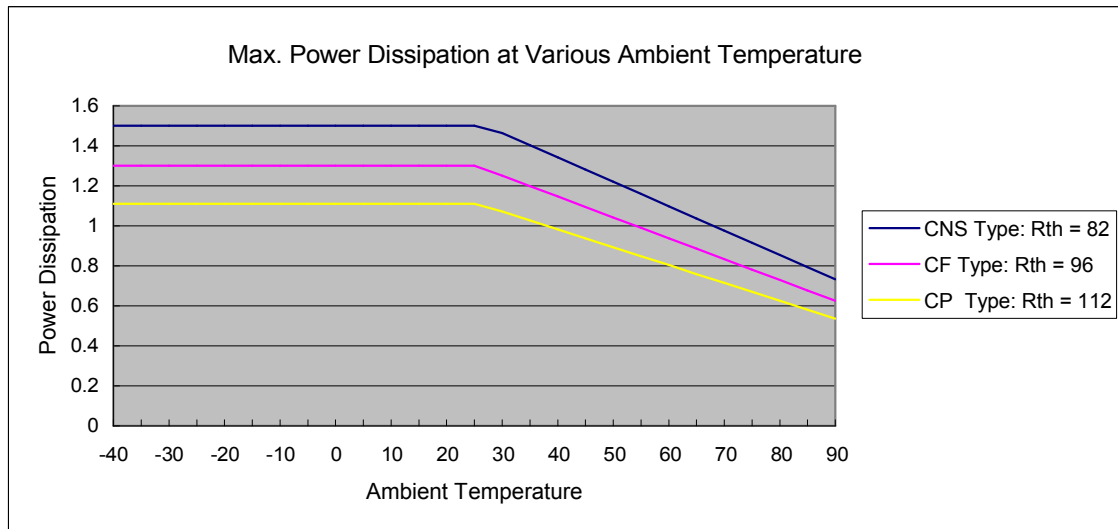

Load Supply Voltage (V_{LED})

MBI5027 are designed to operate with V_{DS} ranging from 0.4V to 1.0V considering the package power dissipating limits. V_{DS} may be higher enough to make $P_{D(act)} > P_{D(max)}$ when $V_{LED} = 5V$ and $V_{DS} = V_{LED} - V_f$, in which V_{LED} is the load supply voltage. In this case, it is recommended to use the lowest possible supply voltage or to set an external voltage reducer, V_{DROP} .

A voltage reducer lets $V_{DS} = (V_{LED} - V_f) - V_{DROP}$.

Resistors or Zener diode can be used in the applications as the following figures.

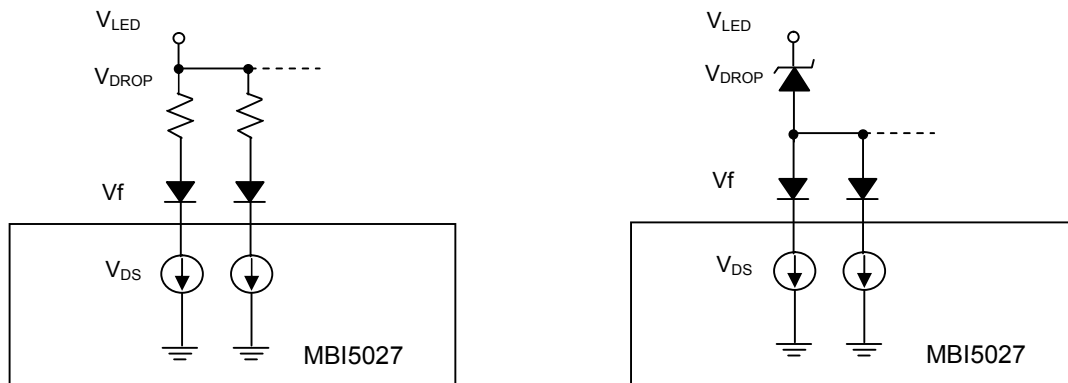

MBI5027CP Outline Drawing

