

features

- Small size power type resistor
- Coated with UL94V0 equivalent flameproof material
- Suitable for automatic machine insertion
- Marking: Pink body color with color-coded bands or alpha-numeric black marking
- Products with lead-free terminations meet EU RoHS and China RoHS requirements
- Surface mount style “N” forming is suitable for automatic mounting

dimensions and construction

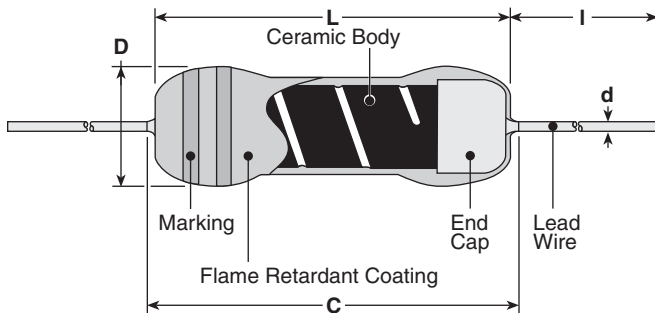

Type	Dimensions inches (mm)				
	L	C (max.)	D	d (nom.)	I*
MOS1/2 MOSX1/2	.244±.02 (6.2±0.5)	.280 (7.1)	.098±.02 (2.5±0.5)	.024 (0.6)	.945 Min. (24.0 Min.)
MOS1 MOSX1	.354±.039 (9.0±1.0)	.437 (11.1)	.118±.02 (3.0±0.5)	.031 (0.8)	
MOS2 MOSX2	.472±.039 (12.0±1.0)	.591 (15.0)	.157±.02 (4.0±0.5)		
MOS3 MOSX3	.610±.039 (15.5±1.0)	.709 (18.0)	.236±.039 (6.0±1.0)		1.18±.118 (30.0±3.0)
MOS5 MOSX5	.965±.039 (24.5±1.0)	1.10 (28.0)	.354±.039 (9.0±1.0)	1.50±.118 (38.0±3.0)	

* Lead length changes depending on taping and forming type.

ordering information

New Part #	MOS	1/2	C	T52	A	103	J
Type	MOS MOSX	Power Rating 1/2: 0.5W 1: 1W 2: 2W 3: 3W 5: 5W	Termination Material C: SnCu	Taping and Forming Axial: T26, T52, T521, T631 Stand-off Axial: L52, L521, L631 Radial: VTP, VTE, GT, GT4, VTF L, U, M, N Forming	Packaging A: Ammo R: Reel TEB, TEG: Plastic embossed (N forming)	Nominal Resistance ±2%, ±5%: 2 significant figures + 1 multiplier “R” indicates decimal on value <10Ω ±1%: 3 significant figures + 1 multiplier “R” indicates decimal on value <100Ω	Tolerance F: ±1% G: ±2% J: ±5%

For further information on packaging, please refer to Appendix C.

reduced size metal oxide power type leaded resistor

applications and ratings

Part Designation	Power Rating @ 70°C	Minimum Dielectric Withstanding Voltage	T.C.R. (ppm/°C) Max.	Resistance Range			Absolute Maximum Working Voltage	Absolute Maximum Overload Voltage	Operating Temperature Range
				E-24, E-96* (F±1%)	E-24* (G±2%)	E-24 (J±5%)			
MOS1/2	0.5W	400V	±300	10Ω - 47kΩ	10Ω - 47kΩ	10Ω - 47kΩ	300V	600V	-55°C to +200°C
MOS1	1.0W	500V		10Ω - 68kΩ	10Ω - 68kΩ	10Ω - 100kΩ	350V		
MOS2	2.0W			10Ω - 100kΩ	10Ω - 100kΩ			500V	
MOS3	3.0W	700V		—	10Ω - 100kΩ	10Ω - 100kΩ			
MOS5	5.0W	800V		—	—	—	500V	1000V	
MOSX1/2	0.5W	400V		—	—	—	—	—	
MOSX1	1.0W	500V		1Ω - 9.1Ω	—	—	$E = \sqrt{P \times R}$	E x 2.5	
MOSX2	2.0W			0.22Ω - 9.1Ω	0.1Ω - 9.1Ω				
MOSX3	3.0W	700V		—	—	—	—	—	
MOSX5	5.0W	800V		—	—	—	—	—	

* Please consult when there is a demand of the resistance besides the 1% and 2% range.

environmental applications

Derating Curve

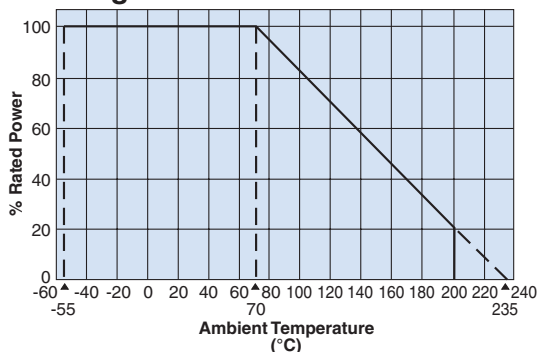

Surface Temperature Rise

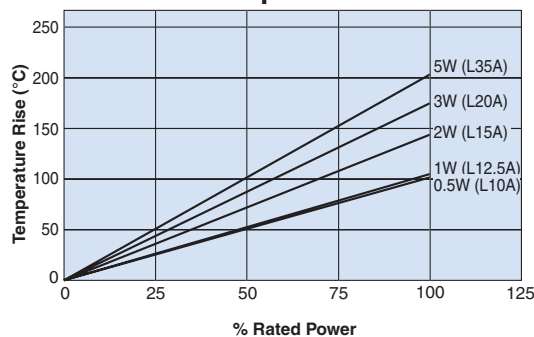

For resistors operated at an ambient temperature of 70°C or above, a power rating shall be derated in accordance with the above derating curve.

Performance Characteristics

Parameter	Requirement $\Delta R \pm(\% + 0.05\Omega)$		Test Method
	Limit	Typical	
Resistance	Within specified tolerance	—	Measuring points are at 10mm ±1mm from the end cap.
T.C.R.	Within specified T.C.R.	—	Room temperature +100°C
Overload (Short time)	±(2% +0.1Ω)	±1%	Rated voltage x 2.5 for 5 seconds
Resistance to Solder Heat	±1%	±0.5%	260°C ±5°C, 10 seconds ± 1 second
Terminal Strength	No lead-coming off and loose terminals	—	Twist 360°C, 5 times
Rapid Change of Temperature	±1%	±0.5%	-55°C (30 minutes), +155°C (30 minutes), 5 cycles
Moisture Resistance	±(5%+0.1Ω)	±2.5%	40°C ± 2°C, 90 - 95% RH, 1000 hours, 1.5 hr ON, 0.5 hr OFF cycle
Endurance at 70°C	±(5%+0.1Ω)	±2.5%	70°C ± 2°C, 1000 hours, 1.5 hr ON, 0.5 hr OFF cycle
Resistance to Solvent	No abnormality in appearance. Marking shall be easily legible	—	Ultrasonic washing with isopropyl alcohol for 2 minutes. Power: 0.3W/cm ³ , f: 28kHz, Temp: 35°C ±5°C
Flame Retardant	No evidence of flaming or self-flaming	—	Flame test: the test flame shall be applied and removed for each 15 seconds respectively to repeat the cycle 5 times. Overload flame retardant: power (AC) corresponding to 2, 4, 8, 16 and 32 times the power rating shall be applied for each 1 minute until disconnection occurs. However the applied voltage shall not exceed the value of 4 times of the maximum operating voltage

secondary processed products

L Forming

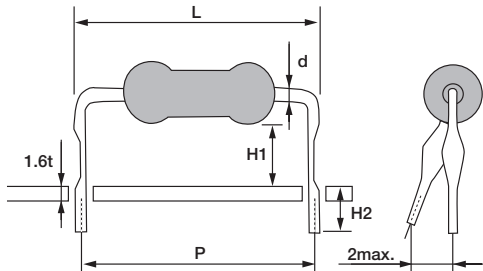

Type	Dimensions millimeters				Substrate Hole Dia.
	P	H1	H2	d (Nom.)	
1/2CL10A	10.0±1.0	5.3±1.0	4.0	0.6	ø0.8
1CL12.5A	12.5±1.0	7.0±1.0		17.5	
1CL15A	15.0±1.0	6.5±1.0			
2CL15A		7.0±1.0			
2CL15F	4.5±1.0				
2CL20A	20.0±1.0	9.0±1.0			
2CL20D		4.8±1.0			
3CL20A		8.0±1.0			
3CL20C		10.0±1.0			
3CL20T	4.0±1.0	7.0±1.0			
3CL25A	25.0±1.0				
3CL30A	30.0±1.0				
5CL30A	35.0±1.0	8.5±1.0	0.8	ø1.0	
5CL35A		5.5±1.0			

M Forming

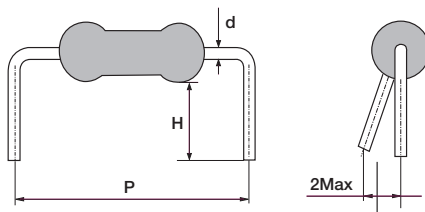

Type	Dimensions millimeters			Substrate Hole Dia.
	P	H	d (Nom.)	
1/2CM10C	10.0±1.0	3.5±1.0	0.6	ø0.8
1/2CM10F	10.0±1.0	5.0±1.0	0.6	
1CM12.5C	12.5±1.0	3.5±1.0	0.8	ø1.0
1CM12.5D	12.5±1.0	4.0±1.0	0.8	
1CM15F	15.0±1.0	5.0±1.0	0.8	
1CM15J	15.0±1.0	6.3±1.0	0.8	
1CM15S	15.0±1.0	11.0±1.0	0.8	
2CM15C	15.0±1.0	3.5±1.0	0.8	
2CM15E	15.0±1.0	4.5±1.0	0.8	
2CM16D	16.0±1.0	4.0±1.0	0.8	
2CM20D	20.0±1.0	4.0±1.0	0.8	
2CM20U	20.0±1.0	13.5±1.0	0.8	
3CM20E	20.0±1.0	4.6±1.0	0.8	
3CM26E	26.0±1.0	4.7±1.0	0.8	
5CM30U	30.0±1.0	13.0±1.0	0.8	

UCL Forming

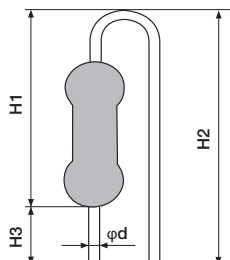

Type	Dimensions millimeters				Insertion Pitch	Substrate Hole Dia.
	H1	H2	H3	d (Nom.)		
1CUCL	13.0±1.0	16.0±1.0	3.5±1.0	0.8	5.0	ø1.0
2CUCL	14.5±1.0	17.5±1.0	3.5±1.0			
3CUCL	18.0±1.0	22.0±1.0	4.0±1.0			

secondary processed products (continued)

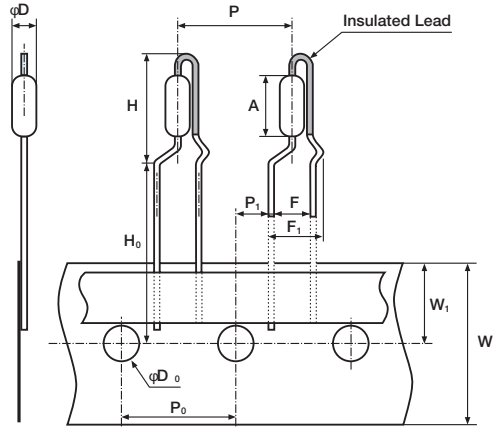
VTF Radial Taping

Type	1/2C	1C	2C	2C
	VTP	VTP	VTP	VTF
A	6.2±0.5	9.0±1.0	12.0±1.0	12.0±1.0
øD	2.5±0.5	3.0±0.5	4.0±0.5	4.0±0.5
d (Nom.)	0.6	0.6	0.65	0.8
F	5.0±0.5	5.0±0.5	5.0±0.5	5.0±0.5
F1	—	—	—	7.3 max.
H	13 max.	16 max.	22.5 max.	22.5 max.
H0	16.0+1.0/-0	16.0+1.0/-0	16.0+1.0/-0	16.0+1.0/-0
P	12.7±1.0	12.7±1.0	12.7±1.0	12.7±1.0
P0	12.7±0.3	12.7±0.3	12.7±0.3	12.7±0.3
P1	3.85±0.7	3.85±0.7	3.85±0.7	3.85±0.7
W	18.0±0.5	18.0±0.5	18.0±0.5	18.0±0.5
W1	9.0±0.5	9.0±0.5	9.0±0.5	9.0±0.5
øD0	4.0±0.2	4.0±0.2	4.0±0.2	4.0±0.2
Substrate Hole Dia.	ø0.8	ø0.8	ø0.8	ø1.0

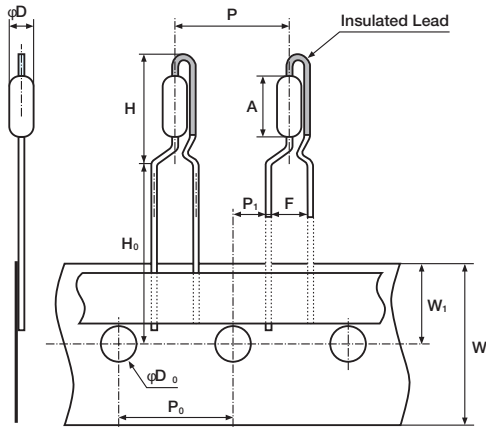
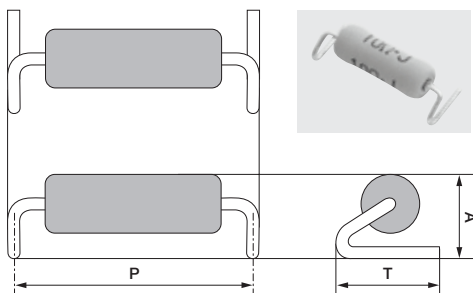
VTP Radial Taping

N Forming

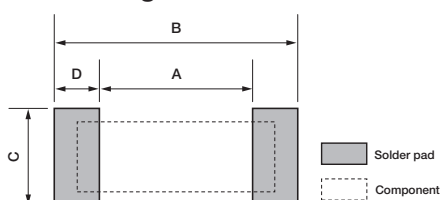
Type	1C	2C	3C
	N14.5TEB	N17TEB	N20TEG
P±1	14.5	17.0	20.0
T±0.5	5.0	6.0	7.5±1.0
A±0.5	4.8	5.8	6.5
d (Nom.)	0.8	0.8	0.8

UCL Forming

Type	1C	2C	3C
	N14.5TEB	N17TEB	N20TEG
A	12.5	14.6	17.6
B	16.5	19.4	22.4
C	7.0	8.0	9.5
D	2.0	2.4	2.4