



Precision JFET-Input Operational Amplifier

ANALOG DEVICES INC

65E D

OP-16

1.0 SCOPE

This specification covers the detail requirements for a precision JFET operational amplifier.

It is highly recommended that this data sheet be used as a baseline for new military or aerospace spec control drawings.

1.2 Part Number. The complete part numbers per Table I of this specification follow:

Device	Part Number	Package
A	OP-16AJ/883	J
B	OP-16BJ/883	J
B	OP-16BZ/883	Z
C	OP-16CZ/883	Z

1.2.3 Case Outline.

Letter	Case Outline (Lead finish per MIL-M-38510)
J	8-lead metal can (TO-99)
Z	8-lead ceramic dual-in-line package (CERDIP)

1.3 Absolute Maximum Ratings. ($T_A = 25^\circ\text{C}$, unless otherwise noted)

Supply Voltage.....	$\pm 22\text{V}$
C Grade Only	$\pm 18\text{V}$
Internal Power Dissipation	500mW
Maximum Junction Temperature	$+150^\circ\text{C}$
DICE Junction Temperature Range (T_J)	-65°C to $+150^\circ\text{C}$
Differential Input Voltage.....	$\pm 40\text{V}$
C Grade Only	$\pm 30\text{V}$
Input Voltage (Note 1)	$\pm 20\text{V}$
C Grade Only	$\pm 16\text{V}$
Output Short-Circuit Duration	Indefinite
Storage Temperature Range.....	-65°C to $+150^\circ\text{C}$
Lead Temperature (Soldering, 60 sec).....	$+300^\circ\text{C}$
Operating Temperature Range	-55°C to $+125^\circ\text{C}$

NOTES:

1. For supply voltages less than $\pm 22\text{V}$, the absolute maximum input voltage is equal to the supply voltages.

1.5 Thermal Characteristics:

Thermal Resistance, TO-99 (J) package:
 Junction-to-Case (θ_{JC}) = 45°C/W MAX
 Junction-to-Ambient (θ_{JA}) = 150°C/W MAX

Thermal Resistance, CERDIP (Z) package:
 Junction-to-Case (θ_{JC}) = 26°C/W MAX
 Junction-to-Ambient (θ_{JA}) = 119°C/W MAX

12 OPERATIONAL AMPLIFIERS

ANALOG DEVICES INC

TABLE 1

$V_S = \pm 15V$; $R_S = 50\Omega$; $V_{CM} = 0V$; $T_A = 25^\circ C$ unless otherwise specified.

Characteristics	Symbol	Special Conditions	OP-16/883				Units
			LIMITS A		LIMITS B		
			Min	Max	Min	Max	
Input Offset Voltage	V_{OS}	$-55^\circ C \leq T_A \leq +125^\circ C$	--	0.5	--	1.0	mV
			--	0.9	--	2.0	mV
Input Offset Current	I_{OS}	$V_S = \pm 20V, T_J = +25^\circ C$	--	10.0	--	20.0	pA
		$V_S = \pm 20V, T_J = +125^\circ C$	--	4.0	--	6.0	nA
Input Bias Current	I_B	$V_S = \pm 20V, T_J = +25^\circ C$	--	± 50.0	--	± 100.0	pA
		$V_S = \pm 20V, T_J = +125^\circ C$	--	± 5.0	--	± 7.5	nA
Large-Signal Voltage Gain	A_{VO}	$V_O = \pm 10V, R_L \geq 2k\Omega$	100.0	--	75.0	--	V/mV
		$V_O = \pm 10V, R_L \geq 2k\Omega$	35.0	--	30.0	--	V/mV
		$-55^\circ C \leq T_A \leq +125^\circ C$					
Output Voltage Swing	V_O	$R_L \geq 2k\Omega$	± 11.0	--	± 11.0	--	V
		$R_L \geq 10k\Omega$	± 12.0	--	± 12.0	--	V
		$-55^\circ C \leq T_A \leq +125^\circ C$					
Supply Current	I_{SY}	$V_O = 0V$	--	7.0	--	7.0	mA
Power Dissipation	P_d	$V_O = 0V$	--	210	--	210	mW
Slew Rate	SR	$A_{VCL} = +1$ $R_L \geq 2k\Omega, C_L = 100pF$	18.0	--	12.0	--	V/ μs
Common-Mode Rejection	CMR	$V_{CM} = I_{VR} = \pm 10.5V$	86	--	86	--	dB
		$V_{CM} = I_{VR} = \pm 10.4V$	85	--	85	--	dB
		$-55^\circ C \leq T_A \leq +125^\circ C$					
Power Supply Rejection	PSR	$V_S = \pm 10V$ to $\pm 18V$	86	--	86	--	dB
		$V_S = \pm 10V$ to $\pm 18V$	85	--	85	--	dB
		$-55^\circ C \leq T_A \leq +125^\circ C$					
Input Voltage Range (Note 1)	IVR	$-55^\circ C \leq T_A \leq +125^\circ C$	± 10.5	--	± 10.5	--	V
			± 10.4	--	± 10.4	--	V

TABLE 1 (Continued)

$V_S = \pm 15V$; $R_S = 50\Omega$; $V_{CM} = 0V$; $T_A = 25^\circ C$ unless otherwise specified.

Characteristics	Symbol	Special Conditions	OP-16/883				Units
			LIMITS A		LIMITS B		
			Min	Max	Min	Max	
Gain Bandwidth Product	GBW	$f_O = 100kHz$	6.0	—	5.5	—	MHz

NOTES:

1. IVR is defined as the V_{CM} range used for the CMR test.

TABLE 1 (Continued)

$V_S = \pm 15V$; $R_S = 50\Omega$; $V_{CM} = 0V$; $T_A = 25^\circ C$ unless otherwise specified.

Characteristics	Symbol	Special Conditions	OP-16/883		Units
			LIMITS C		
			Min	Max	
Input Offset Voltage	V_{OS}	$-55^\circ C \leq T_A \leq +125^\circ C$	--	3.0	mV
			--	4.5	mV
Input Offset Current	I_{OS}	$V_S = \pm 20V, T_J = +25^\circ C$	--	50.0	pA
		$V_S = \pm 20V, T_J = +125^\circ C$	--	9.0	nA
Input Bias Current	I_B	$V_S = \pm 20V, T_J = +25^\circ C$	--	± 200.0	pA
		$V_S = \pm 20V, T_J = +125^\circ C$	--	± 10.0	nA
Large-Signal Voltage Gain	A_{VO}	$V_O = \pm 10V, R_L \geq 2k\Omega$	50.0	--	V/mV
		$V_O = \pm 10V, R_L \geq 2k\Omega$ $-55^\circ C \leq T_A \leq +125^\circ C$	25.0	--	V/mV
Output Voltage Swing	V_O	$R_L \geq 2k\Omega$	± 11.0	--	V
		$R_L \geq 10k\Omega$ $-55^\circ C \leq T_A \leq +125^\circ C$	± 12.0	--	V
Supply Current	I_{SY}	$V_O = 0V$	--	8.0	mA
Power Dissipation	P_d	$V_O = 0V$	--	240	mW
Slew Rate	SR	$A_{VCL} = +1$ $R_L \geq 2k\Omega, C_L = 100pF$	9.0	--	V/ μs
Common-Mode Rejection	CMR	$V_{CM} = IVR = \pm 10.3V$	82	--	dB
		$V_{CM} = IVR = \pm 10.25V$ $-55^\circ C \leq T_A \leq +125^\circ C$	80	--	dB
Power Supply Rejection	PSR	$V_S = \pm 10V$ to $\pm 15V$	82	--	dB
		$V_S = \pm 10V$ to $\pm 15V$ $-55^\circ C \leq T_A \leq +125^\circ C$	80	--	dB

ANALOG DEVICES INC

TABLE 1 (Continued)

$V_S = \pm 15V$; $R_S = 50\Omega$; $V_{CM} = 0V$; $T_A = 25^\circ C$ unless otherwise specified.

Characteristics	Symbol	Special Conditions	OP-16/883		Units
			LIMITS C		
			Min	Max	
Input Voltage Range (Note 1)	IVR	$-55^\circ C \leq T_A \leq +125^\circ C$	± 10.3	--	V
Gain Bandwidth Product	GBW	$f_O = 100kHz$	5	--	MHz

NOTES:

1. IVR is defined as the V_{CM} range used for the CMR test.

TABLE 2

OP-16/883

**Electrical Test Requirements
For Class B Devices**

MIL-STD-883 Test Requirements	Subgroups (see Table 3)
Interim Electrical Parameters (pre Burn-In)	1
Final Electrical Test Parameters	1*, 2, 3, 4, 5, 6
Group A Test Requirements	1, 2, 3, 4, 5, 6, 7

* PDA applies to Subgroup 1 only.
For "A" grade product, V_{OS} and I_{OS} are excluded from PDA.
For "B" grade product, V_{OS} is excluded from PDA.

TABLE 3

Group A Inspection

$V_S = \pm 15V$; $R_S = 50\Omega$; $V_{CM} = 0V$; $T_A = T_J$ unless otherwise specified.

Subgroup	Symbol	Special Conditions	OP-16/883				Units
			LIMITS A		LIMITS B		
			Min	Max	Min	Max	
Subgroup 1 $T_A = +25^\circ C$	V_{OS}		--	0.5	--	1.0	mV
	I_{OS}	$V_S = \pm 20V$	--	10.0	--	20.0	pA
	I_B	$V_S = \pm 20V$	--	± 50.0	--	± 100.0	pA
	I_{SY}		--	7.0	--	7.0	mA
	CMR	$V_{CM} = \pm 10.5V$	86	--	86	--	dB
	PSR	$V_S = \pm 10V, \pm 18V$	86	--	86	--	dB
Subgroup 2 $T_A = +125^\circ C$	V_{OS}		--	0.9	--	2.0	mV
	I_{OS}	$V_S = \pm 20V$	--	4.0	--	6.0	nA
	I_B	$V_S = \pm 20V$	--	± 5.0	--	± 7.5	nA
	CMR	$V_{CM} = \pm 10.4V$	85	--	85	--	dB
	PSR	$V_S = \pm 10V, \pm 18V$	85	--	85	--	dB
Subgroup 3 $T_A = -55^\circ C$	V_{OS}		--	0.9	--	2.0	mV
	CMR	$V_{CM} = \pm 10.4V$	85	--	85	--	dB
	PSR	$V_S = \pm 10V, \pm 18V$	85	--	85	--	dB
Subgroup 4 $T_A = +25^\circ C$	V_O	$R_L = 2k\Omega$	± 11.0	--	± 11.0	--	V
	A_{VO}	$V_O = \pm 10V, R_L = 2k\Omega$	100.0	--	75.0	--	V/mV
Subgroup 5 $T_A = +125^\circ C$	V_O	$R_L = 10k\Omega$	± 12.0	--	± 12.0	--	V
	A_{VO}	$V_O = \pm 10V, R_L = 2k\Omega$	35.0	--	30.0	--	V/mV

ANALOG DEVICES INC

TABLE 3

Group A Inspection (Continued)

$V_S = \pm 15V$; $R_S = 50\Omega$; $V_{CM} = 0V$; $T_A = T_J$ unless otherwise specified.

Subgroup	Symbol	Special Conditions	OP-16/883				Units
			LIMITS A		LIMITS B		
			Min	Max	Min	Max	
Subgroup 6 $T_A = -55^\circ C$		All Tests, Limits and Conditions are the same as for Subgroup 5.					
Subgroup 7 $T_A = +25^\circ C$	SR	$A_{VCL} = +1$ $R_L = 2k\Omega, C_L = 100pF$	18.0	—	12.0	—	V/ μ s
	GBW	$f_O = 100kHz$	6	—	5.5	—	MHz

TABLE 3

Group A Inspection (Continued)

$V_S = \pm 15V$; $R_S = 50\Omega$; $V_{CM} = 0V$; $T_A = T_J$ unless otherwise specified.

Subgroup	Symbol	Special Conditions	LIMITS C		Units
			Min	Max	
OP-16/883					
Subgroup 1	V_{OS}		--	3.0	mV
$T_A = +25^\circ C$	I_{OS}	$V_S = \pm 20V$	--	50.0	pA
	I_B	$V_S = \pm 20V$	--	± 200.0	pA
	I_{SY}		--	8.0	mA
	CMR	$V_{CM} = \pm 10.3V$	82	--	dB
	PSR	$V_S = \pm 10V, \pm 15V$	82	--	dB
Subgroup 2	V_{OS}		--	4.5	mV
$T_A = +125^\circ C$	I_{OS}	$V_S = \pm 20V$	--	9.0	nA
	I_B	$V_S = \pm 20V$	--	± 10.0	nA
	CMR	$V_{CM} = \pm 10.25V$	80	--	dB
	PSR	$V_S = \pm 10V, \pm 15V$	80	--	dB
	Subgroup 3	V_{OS}		--	4.5
$T_A = -55^\circ C$	CMR	$V_{CM} = \pm 10.25V$	80	--	dB
	PSR	$V_S = \pm 10V, \pm 15V$	80	--	dB
Subgroup 4	V_O	$R_L = 2k\Omega$	± 11.0	--	V
$T_A = +25^\circ C$	A_{VO}	$V_O = \pm 10V, R_L = 2k\Omega$	50.0	--	V/mV
Subgroup 5	V_O	$R_L = 10k\Omega$	± 12.0	--	V
$T_A = +125^\circ C$	A_{VO}	$V_O = \pm 10V, R_L = 2k\Omega$	25.0	--	V/mV

TABLE 3

Group A Inspection (Continued)

$V_S = \pm 15V$; $R_S = 50\Omega$; $V_{CM} = 0V$; $T_A = T_J$ unless otherwise specified.

Subgroup	Symbol	Special Conditions	OP-16/883		Units
			<u>LIMITS C</u>		
			Min	Max	
Subgroup 6 $T_A = -55^\circ C$		All Tests, Limits and Conditions are the same as for Subgroup 5.			
Subgroup 7 $T_A = +25^\circ C$	SR	$A_{VCL} = +1$ $R_L = 2k\Omega, C_L = 100pF$	9.0	—	V/ μs
	GBW	$f_O = 100kHz$	5	—	MHz

3.2.1 Simplified Schematic and Pin Connections.

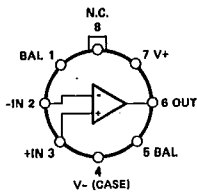
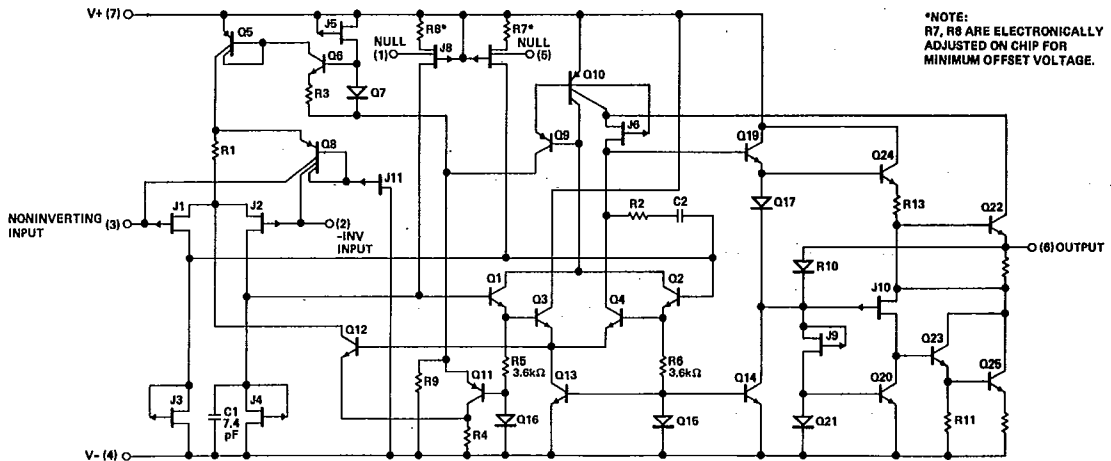

**TO-99
(J-Suffix)**

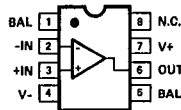

**8-PIN HERMETIC DIP
(Z-Suffix)**

3.2.4 Microcircuit Group Assignment. This microcircuit is covered by microcircuit group 61.

4.2 Life Test/Burn-In Circuit.

