

M Series



Applications

Submarine : Sonars, degaussing, bulkhead
 Subsea defense : mines, TAS
 Underwater instrumentation : Cameras, hydrophones, diving
 Water pollution control : Pumps, valves
 Offshore and oceanography : ROV, subsea control, platform

Standard

Proprietary product line



Description

• Rugged screw coupling connectors in high corrosion resistant shells which are made in nickel aluminum bronze alloy. The design provides a very high reliability with dry mate sealing down to 2.000 meters immersion (deeper depth with special backshells). The M marine connector series is approved by VERITAS and LLOYD'S Register of shipping.

Mechanical

Pressures	Test pressure	Insert in Teflon®		Insert in Kel'f®	
		Mated	Unmated	Mated	Unmated
Size 9 M	Test pressure	-	-	200 bars	100 bars
	Operating pressure	-	-	100 bars	50 bars
Other Sizes 10, 14, 20, 24	Test pressure	200 bars	60 bars	200 bars	120 bars
	Operating pressure	100 bars	30 bars	100 bars	60 bars

Connectors double watertightness can withstand higher pressures than those above (test pressure : 300 bars mated connectors).

Note 1 : For long unmated immersion use watertight caps.

Note 2 : Please consult us about higher operating pressure than those above.

Shells : Nickel aluminum bronze :
 Cu A1 9 Ni 3 Fe 2, Scoop-Proof

Inserts : Teflon® = PTFE
 Polytetrafluorethylene.
 or Kel'f® = PCTFE
 Polymonochlorotrifluorethylene
 © Trade marks of Dupont de Nemours Inc.

Types of contacts : Solder unremovable except power contacts (sizes 2 and 6).

Plating of contacts: Gold on nickel

Watertight washers : Neoprene

Polarization : With 5 keys

O-Rings : Nitrile elastomer

Endurance : 500 cycles mating/unmating

Free-Fall : Connecting plug or plug harness < 1,5 m

Electrical features

Service rating at sea level test voltage :

- Voltage rating 1 - 1 500 Vrms 50 Hz
- Voltage rating 2 - 2 300 Vrms 50 Hz
- Voltage rating 3 - 15 000 Vrms 50 Hz

Operation voltage :

- Voltage rating 1 - 600 Vrms 50 Hz
- Voltage rating 2 - 1 000 Vrms 50 Hz
- Voltage rating 3 - 7 000 Vrms 50 Hz

Dielectric resistance : ≥ 5000 megohms at 20°C and 60 % relative humidity

Grounding resistance : (receptacle and plug assembled) ≤ 10 mΩ at 20 °C and 60 % relative humidity

Environmental

Temperature range : -20°C +70°C -68°F +158°F

Marine environment : 30 years ageing

Vibrations :

From 0,1Hz to 1 Hz : amplitude = 25 mm
 From 1Hz to 5 Hz : acceleration = 0,1 g
 From 5Hz to 22Hz : amplitude = 1 mm
 From 22Hz to 50Hz : acceleration = 2 g
 Duration 1 hour on each axis

Shocks : Static acceleration of 120 g on each axis

Fluids resistance : oil, alcohol, petrol, diesel fuel, sea water

Various gases : natural, butane, propane, freon

Various acids

M Series



Dimensions and electrical features of contacts

	Size	Ø (mm)	Solder well Ø (mm)	Contacts		cables		
				Nominal current (Amp.)	Contact resistance (mΩ)	AWG Gauge		
						Cross section in mm ²		
For connectors size 9M	20	1.02	0.9 +0.1 0	7	≤ 4	22	24	26
	16	1.59	1.2 +0.1 0	14	≤ 3	0.38	0.21	0.14
						20	22	24
For connectors sizes 10 M, 14 M, 20 M and 24 M	20	1.02	0.9 +0.1 0	7	≤ 4	22	24	26
	16	1.59	1.4 +0.1 0	14	≤ 3	0.38	0.21	0.14
						18	20	22
	14	1.93	1.9 +0.1 0	20	≤ 2.5	0.93	0.60	0.38
						14	16	18
	12	2.39	2.3 +0.1 0	26	≤ 2	1.91	1.34	0.93
						12	14	16
	6	5	6.2 +0.1 0	65	≤ 1	3.15	1.91	1.30
						6	8	10
	2	7	9.0 +0.1 0	115	≤ 0.6	13.4	8.43	5.15
2						4	6	
TX 50	3	2.6 +0.1 0	26	≤ 2	34.5	21.8	13.4	
TX 75	1.59	1.4 +0.1 0	14	≤ 3	Consult us			
					Consult us			

General configuration

- FED : plug with single watertightness
- PCE : cable connecting plug with single watertightness
- FDED : plug with double watertightness
- PCDE : cable connecting plug with double watertightness
- TER : jam-nut bulkhead
- TEC : square flange bulkhead

- RER : jam-nut receptacle
- REC : square flange receptacle
- BEF : sealing cap for plug
- BER : sealing cap for receptacle or cable connecting plug
- LREC : 105° elbow mounting
- REC-SC : cable clamp receptacle

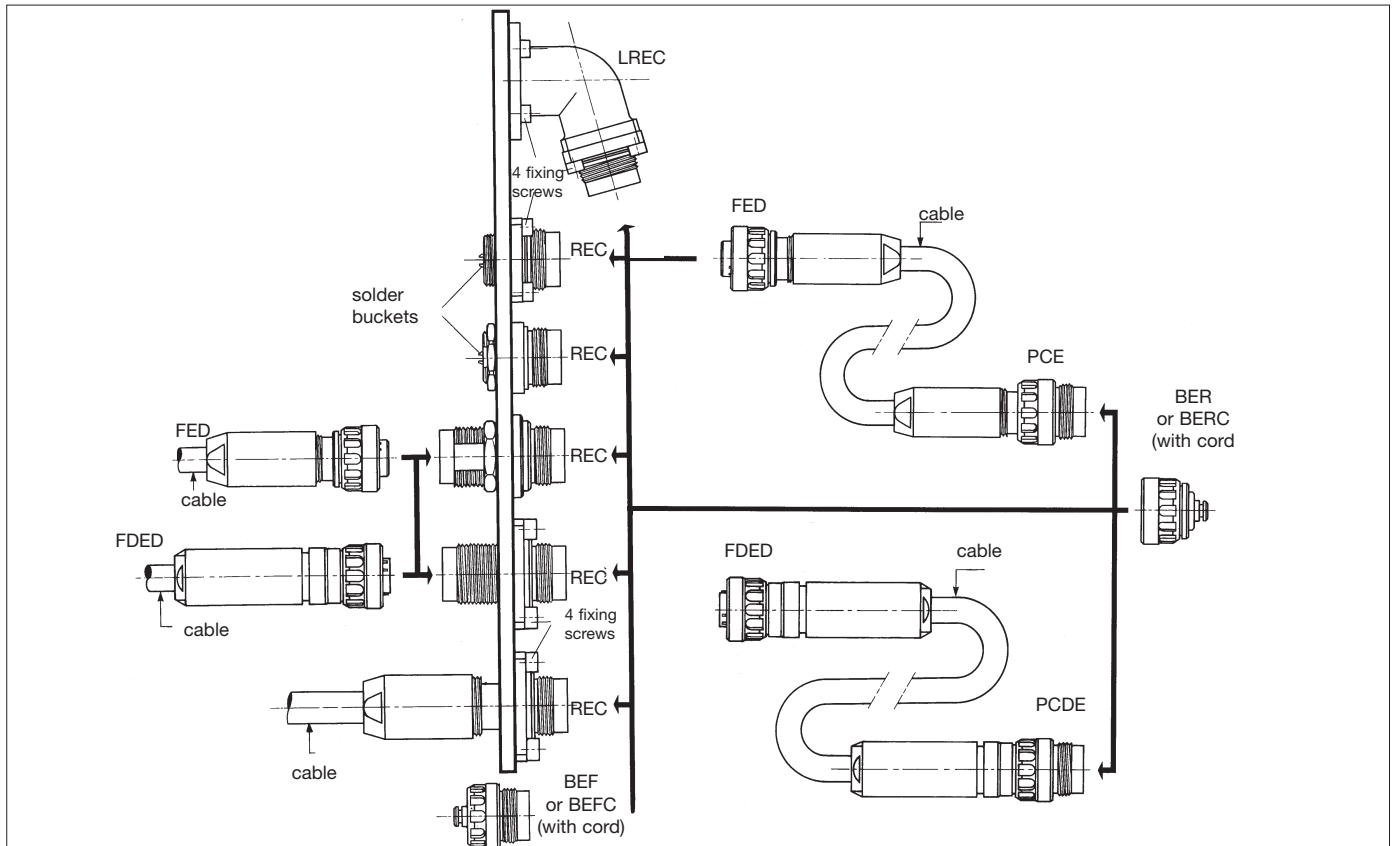

M Series













Ordering information

shell	FED - straight plug/single watertightness PCE - cable connecting plug/single watertightness FDED - straight plug/double watertightness PCDE - cable connecting plug/double watertightness TEC - square flange bulkhead RER - round flange receptacle REC - square flange receptacle TER - feed through bulkhead REC-SC - cable clamp square flange receptacle	FED	M	24 M	T	48.16	M	265
contacts	M - pin F - socket 1- pins and sockets for feed through bulkheads							
shell size	9 M 10 M 14 M 20 M 24 M							
insulating material	T - teflon K - kel'f							
contact layouts	- see table page below							
part number of cable clamp accessories	- see table page 250 nothing for RER - REC and TER							
outside maximum diameter	- of cable (in 1/10th of mm) - for standard cables mention maximum diameter of the specification - for double watertightness version mention diameter on inner sheath too - nothing for RER - REC and TER							

Example : To order a cable connecting plug size 20M with Teflon insulating insert, 16 pins size 12 and standard cable clamp without grounding for cable outside diameter 22.6 mm give part number : PCE M 20 M. T. 16-12. A. 226

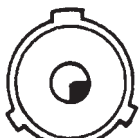
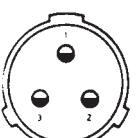





Contact layouts

9 M	 04 - 16 4 contacts size 16 voltage rating : 2 300 V	 07 - 20 7 contacts size 20 voltage rating : 1 500 V		
	 02 - 14 2 contacts size 14 voltage rating : 2 300 V	 03 - 14 3 contacts size 14 voltage rating : 2 300 V	 04 - 16 4 contacts size 16 voltage rating : 2 300 V	 05 - 16 5 contacts size 16 voltage rating : 1 500 V
10 M	 07 - 20 7 contacts size 20 voltage rating : 1 500 V	 1C - 50 1C - 75 1 COAX 50 Ω or 75 Ω voltage rating : 1 500 V	 01 - HT 1 high voltage voltage rating : 15 000 V	
	 01 - 06 1 contact size 06 voltage rating : 2 300 V	 03 - 12 3 contacts size 12 voltage rating : 2 300 V	 04 - 12 4 contacts size 12 voltage rating : 2 300 V	 07 - 14 7 contacts size 14 voltage rating : 2 300 V
14 M				

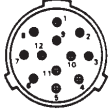
M Series

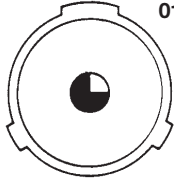

Contact layouts

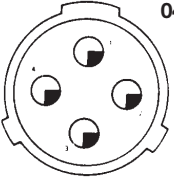
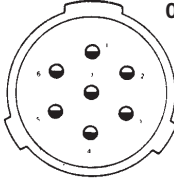
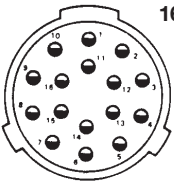
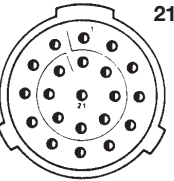
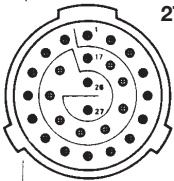
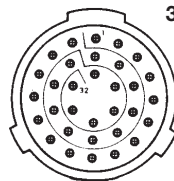
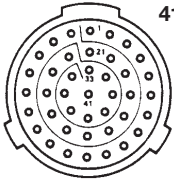
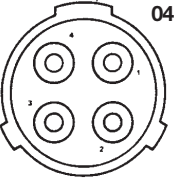
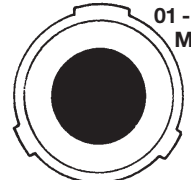
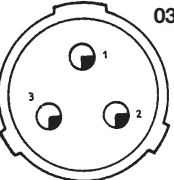
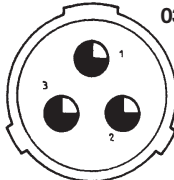
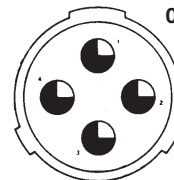
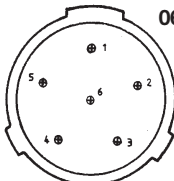
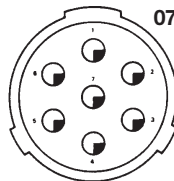
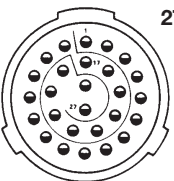
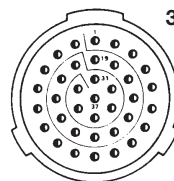
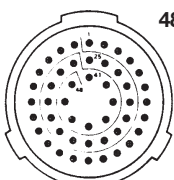
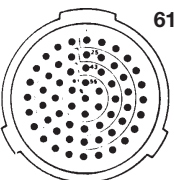
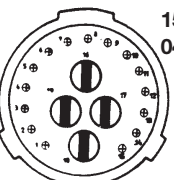
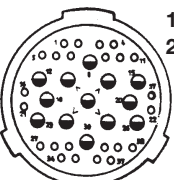
14 M	 <p>12 - 16</p> <p>12 contacts size 16 voltage rating : 2 300 V</p>	 <p>19 - 20</p> <p>19 contacts size 20 voltage rating : 1 500 V</p>	 <p>1 C - 50</p> <p>1 COAX 50 Ω voltage rating : 2 300 V</p>	 <p>TX - 50 or TX - 75</p> <p>1 TRIAX 50 Ω or 75 Ω voltage rating : 2 300 V</p>
	 <p>01 - 02</p> <p>1 contact size 2 voltage rating : 2 300 V</p>	 <p>03 - 06</p> <p>3 contacts size 6 voltage rating : 2 300 V</p>	 <p>04 - 06</p> <p>4 contacts size 6 voltage rating : 2 300 V</p>	 <p>07 - 12</p> <p>7 contacts size 12 voltage rating : 2 300 V</p>
20 M	 <p>16 - 12</p> <p>16 contacts size 12 voltage rating : 2 300 V</p>	 <p>21 - 14</p> <p>21 contacts size 14 voltage rating : 1 500 V</p>	 <p>27 - 16</p> <p>27 contacts size 16 voltage rating : 1 500 V</p>	 <p>32 - 16</p> <p>32 contacts size 16 voltage rating : 1 500 V</p>
	 <p>41 - 20</p> <p>41 contacts size 20 voltage rating : 1 500 V</p>	 <p>04 - HT</p> <p>4 contacts high voltage voltage rating : 15 000 V</p>		
24 M	 <p>01 - 120 MC</p> <p>1 contact cross section 120 mm² nominal current 600 A</p>	 <p>03 - 06</p> <p>3 contacts size 6 voltage rating : 2 300 V</p>	 <p>03 - 02</p> <p>3 contacts size 2 voltage rating : 2 300 V</p>	 <p>04 - 02</p> <p>4 contacts size 2 voltage rating : 2 300 V</p>
	 <p>06 - 16</p> <p>6 contacts size 16 voltage rating : 3 000 V</p>	 <p>07 - 06</p> <p>7 contacts size 6 voltage rating : 2 300 V</p>	 <p>27 - 12</p> <p>27 contacts size 12 voltage rating : 2 300 V</p>	 <p>37 - 14</p> <p>37 contacts size 14 voltage rating : 2 300 V</p>
	 <p>48 - 16</p> <p>48 contacts size 16 voltage rating : 1 500 V</p>	 <p>61 - 16</p> <p>61 contacts size 16 voltage rating : 1 500 V</p>	 <p>15 - 16 04 - 10</p> <p>15 contacts size 16 and 4 contacts size 10 voltage rating : 1 500 V - insulator in kel'f</p>	 <p>13 - 12 24 - 20</p> <p>13 contacts size 12 and 24 contacts size 20 voltage rating : 1 500 V - insulator in kel'f</p>

M Series



The M Series offer two versions :

- Single watertightness for cables with single jacket
- Double watertightness for cables with inner and outer sheaths

Single Watertightness on outer sheath :

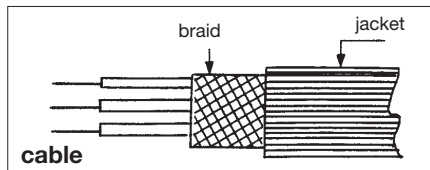
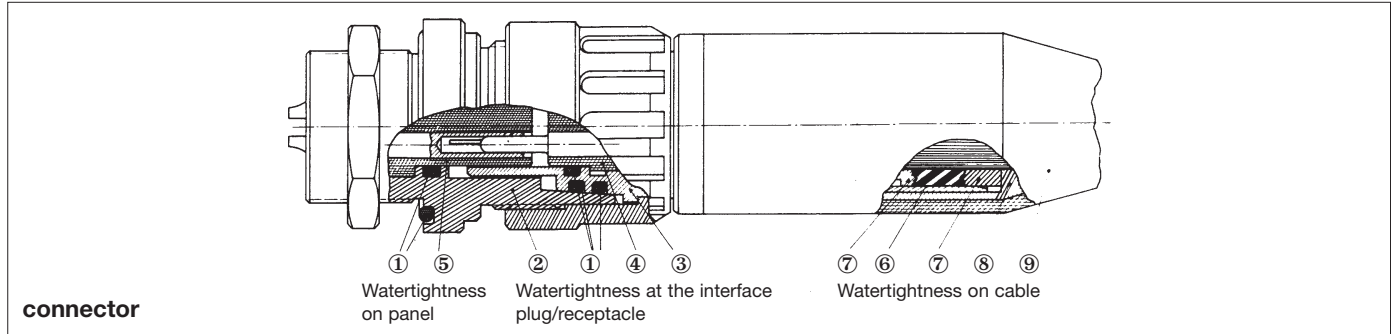

Options : With steel armor / CU braid
Without steel armor / CU braid

- The M Series Single watertightness connectors are available in 5 standard sizes, 9M, 10M, 14M, 20M and 24M. 100 % watertightness is achieved by both o-rings and packing washers inside the metal housings. The packing washers offer waterproofing independently of the cable clamps so that a brutal traction on the cable cannot reduce the watertightness.
- Since the watertightness is not achieved through overmolding or heat vulcanization the assembling of connectors can be made outside

- workshop on the spot when necessary.
- The main parts achieving watertightness can be seen on fig. 1.
 - O-rings (1) are located on receptacles (2), plugs (3) and pin and socket inserts (4) and (5).
 - The packing washer (6) is compressed by metal washers (7) through screwing of the rear tightening metal sleeve (8).
 - The neoprene boot is intended to limit the cable radius curvature.

Double Watertightness on inner and outer sheaths

- FDED straight plug
- PCDE cable connecting plug

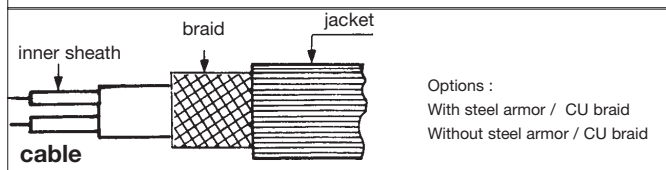
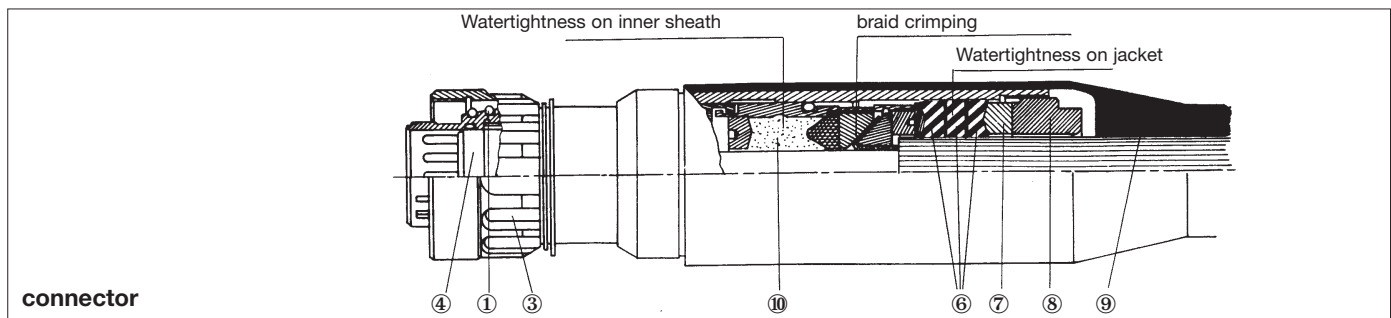

Options :
With steel armor / CU braid
Without steel armor / CU braid

- The M Series double watertightness connectors are available in 3 sizes 14M, 20M and 24M. The watertightness is ensured at two levels :
 - on the outer jacket
 - on the inner sheath.
 Mechanical cable strength is provided by :
 - a mechanical capture of the braid armor
 - a clamping thanks to a metal clamping sleeve on sheath in the event there is no armour.

- The main parts achieving watertightness at the level of the plug can be seen on fig. 2.
 - On the outer jacket, packing washer (6) are compressed by metal tightening sleeve (8).
 - On the inner sheath, compound injection inside a compounding housing (10) ensures a second watertightness level (watertightness relay).
 - The neoprene boot (9) has the same roles as preceding version.

Note : The two versions are compatible with in the following standard M series shells :

- RER receptacle with round flange, front fitting and rear axial nut
- REC receptacle with square flange, front fitting with 4 screws
- TER bulkhead with round flange, front fitting and rear axial nut
- TEC bulkhead with square flange

M Series



Dimensions

Single watertightness version

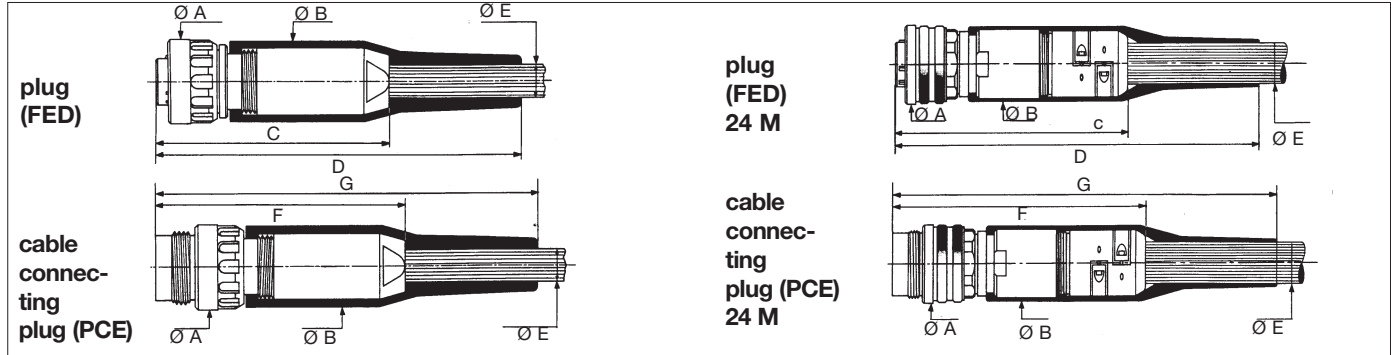

Shell size	Ø A	Ø B	Ø C	Ø D	Ø E Max	Ø F	Ø G
9 M	20.00 .787	18.00 .709	53.00 2.087	79.00 3.110	6.20 .244	57.00 2.244	83.00 3.268
10 M	24.50 .965	21.00 .827	72.00 2.835	110.00 4.331	13.00 .512	81.50 3.209	119.00 4.685
14 M	33.50 1.319	30.00 1.181	90.00 3.543	144.00 5.669	16.00 .630	99.50 3.917	153.00 6.024
20 M	46.00 1.811	42.00 1.654	114.00 4.488	186.00 7.323	26.00 1.024	126.00 4.961	198.00 7.795
24 M	68.00 2.677	62.00 2.441	200.00 7.874	310.00 12.205	31.00 1.220	220.00 8.661	330.00 12.992

Double watertightness version

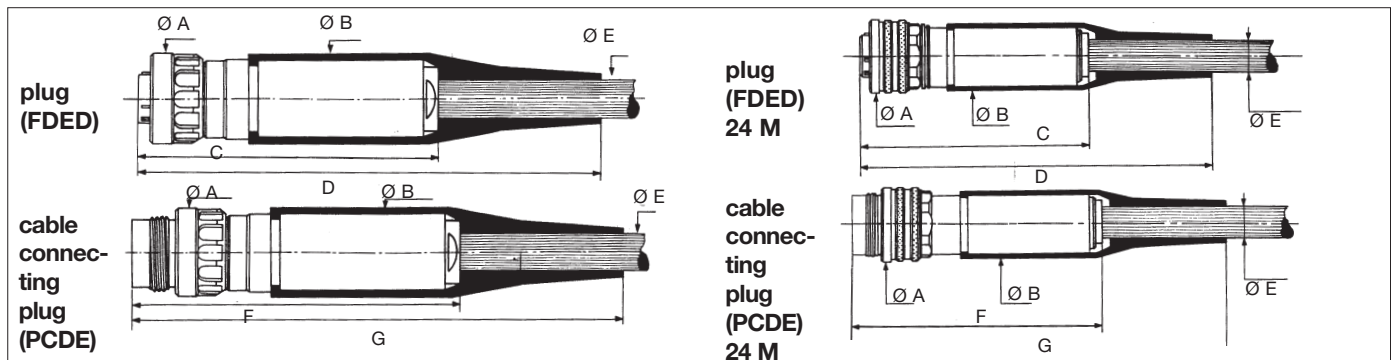

Shell size	Ø A	Ø B	Ø C	Ø D	Ø E Max	Ø F	Ø G
14 M	33.50 1.319	33.50 1.319	115.00 4.528	188.00 7.402	16.00 .630	124.00 4.882	197.00 7.756
20 M	46.00 1.811	51.00 2.008	185.00 7.283	275.00 10.827	22.00 .866	197.00 7.756	287.00 11.299
24 M	68.00 2.677	56.50 2.224	200.00 7.874	310.00 12.205	28.50 1.122	220.00 8.661	330.00 12.992

M Series



Receptacle with round flange (RER)

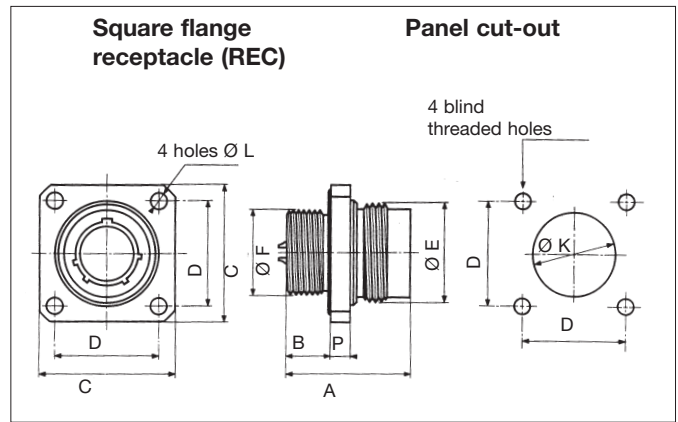
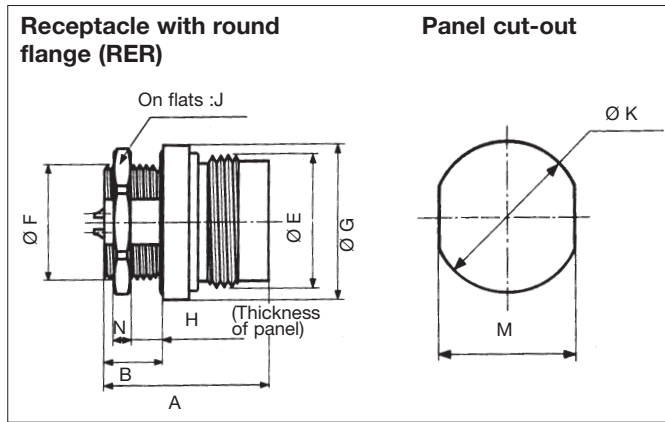

Shell size	A	B	B1	C	D	E	F	F1	G	H	J	K	L	M	N	P	Q	R
9 M	22.00 .866	6.50 .256	7.50 .295	29.00 1.142	20.00 .787	M 17x0.7	M 13x0.7	13.00 .512	20.00 .787	4.00 .157	15.00 .591	13.20 .520	4.50 .177	12.10 .476	3.00 .118	4.00 .157	40.50 1.594	M 4
10 M	37.00 1.457	14.00 .551	14.00 .551	32.00 1.260	24.00 .945	M 21 x 1	M 18x0.75	18.00 .709	25.00 .984	10.00 .394	22.00 .866	18.20 .717	4.20 .165	16.20 .638	4.00 .157	5.00 .197	42.50 1.673	M 4
14 M	37.00 1.457	13.00 .512	13.00 .512	40.00 1.575	31.00 1.220	M 29 x 1	M 25 x 0.75	25.00 .984	34.00 1.339	9.00 .354	30.00 1.181	25.20 .992	5.20 .205	23.20 .913	4.00 .157	6.00 .236	53.50 2.106	M 5
20 M	49.50 1.949	17.00 .669	17.00 .669	52.00 2.047	42.00 1.654	M 41 x 1	M 36 x 1	36.00 1.417	46.00 1.811	12.00 .472	41.00 1.614	36.20 1.425	6.30 .248	33.20 1.307	5.00 .197	8.00 .315	70.50 2.776	M 6
24 M	58.00 2.283	20.00 .787	20.00 .787	76.00 2.992	60.00 2.362	M 56 x 1.5	M 46 x 1.5	46.00 1.811	64.00 2.520	14.00 .551	56.00 2.205	46.20 1.819	8.50 .335	42.20 1.661	6.00 .236	9.00 .354	100.50 3.957	M 8

Square flange bulkhead (TEC)

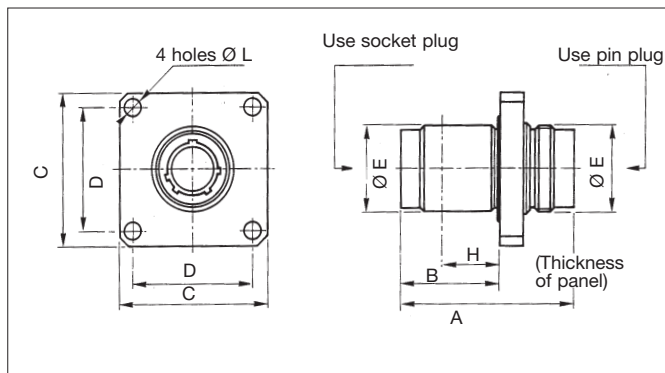

Panel cut-out

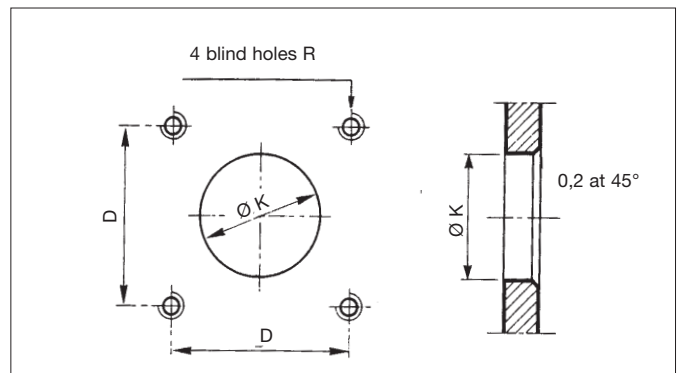

Shell size	A	B	C	D ±0,1	E	H Maxi	K 0 0,1	L	R
10 M	60.00 2.362	35.50 1.398	40.00 1.575	31.00 1.220	21.00 .827	20.00 .787	21.20 .835	5.30 .209	M 5
14 M	60.00 2.362	34.50 1.358	52.00 2.047	42.00 1.654	29.00 1.142	20.00 .787	29.20 1.150	6.30 .248	M 6
20 M	82.00 3.228	47.50 1.870	76.00 2.992	60.00 2.362	41.00 1.614	27.00 1.063	41.20 1.622	8.50 .335	M 8

M Series



Jam-nut bulkhead (TER)

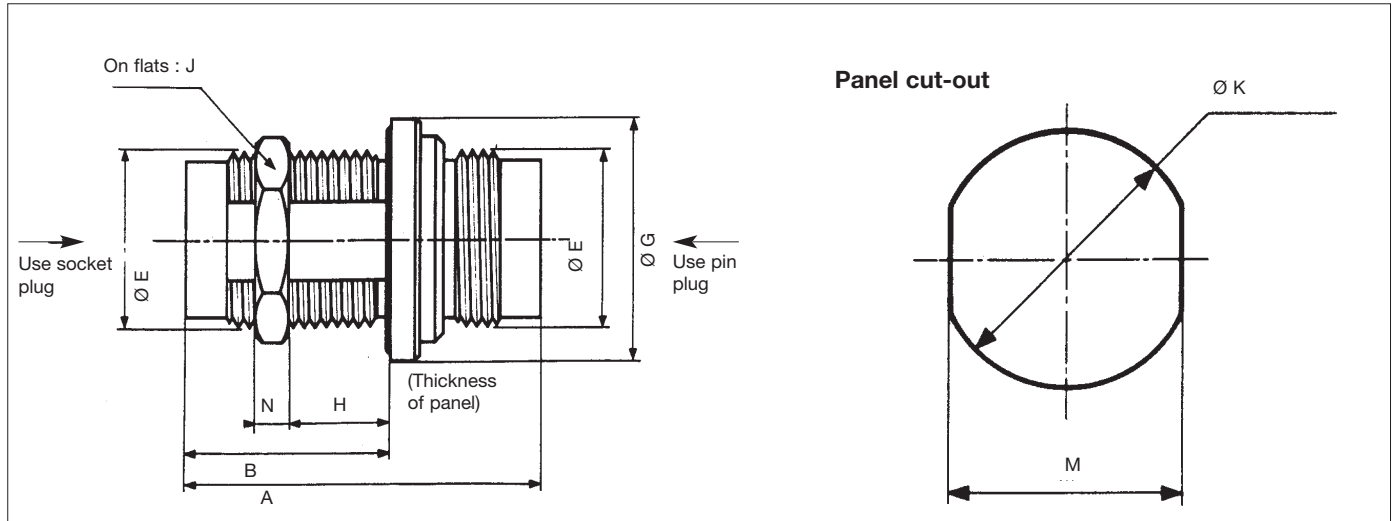

Shell size	A	B	E	G	H Maxi	J	M	K	N
9 M	50.00 1.969	34.00 1.339	M 17 x1	23.00 .906	20.00 .787	20.00 .787	14.20 .559	17.20 .677	4.00 .157
10 M	60.00 2.362	35.50 1.398	M 21 x1	28.00 1.102	16.00 .630	24.00 .945	19.20 .756	21.20 .835	4.00 .157
14 M	60.00 2.362	34.50 1.358	M 29 x 1	40.00 1.575	14.00 .551	34.00 1.339	27.20 1.071	29.20 1.150	5.00 .197
20 M	82.00 3.228	47.50 1.870	M 41 x 1	52.00 2.047	22.00 .866	46.00 1.811	39.20 1.543	41.20 1.622	6.00 .236
24 M	98.00 3.858	57.00 2.244	M 56x1.5	70.00 2.756	24.00 .945	63.00 2.480	50.20 1.976	56.20 2.213	8.00 .315

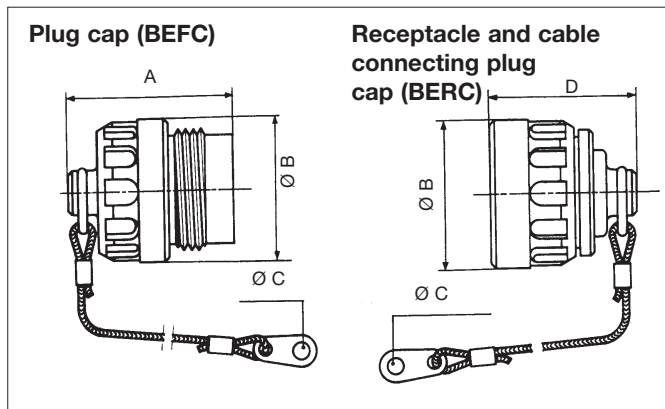

Shell size	PART NUMBER			
	Plug		Receptacle or cable connecting plug	
	with cord	without cord	with cord	without cord
9 M	BEFC - 9 M	BEF - 9 M	BERC - 9 M	BER - 9 M
10 M	BEFC - 10 M	BEF - 10 M	BERC - 10 M	BER - 10 M
14 M	BEFC - 14 M	BEF - 14 M	BERC - 14 M	BER - 14 M
20 M	BEFC - 20 M	BEF - 20 M	BERC - 20 M	BER - 20 M
24 M	BEFC - 24 M	BEF - 24 M	BERC - 24 M	BER - 24 M

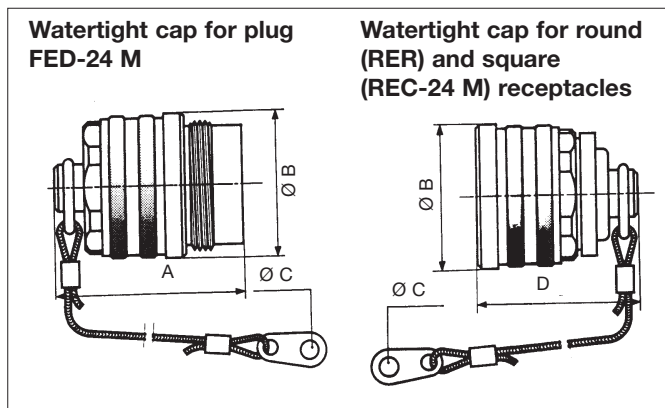

Shell size	A	B	C	D
9 M	30 1.181	21 .827	4.2 .165	27 1.063
10 M	39 1.535	24 .945	4.2 .165	34 1.339
14 M	40 1.575	34 1.339	4.2 .165	34 1.339
20 M	51 2.008	46 1.811	4.2 .165	48.5 1.909
24 M	71 2.795	BEF 64 2.520 BER 68 2.677	4.2 .165	69 2.717

M Series



105 ° Elbow mounting

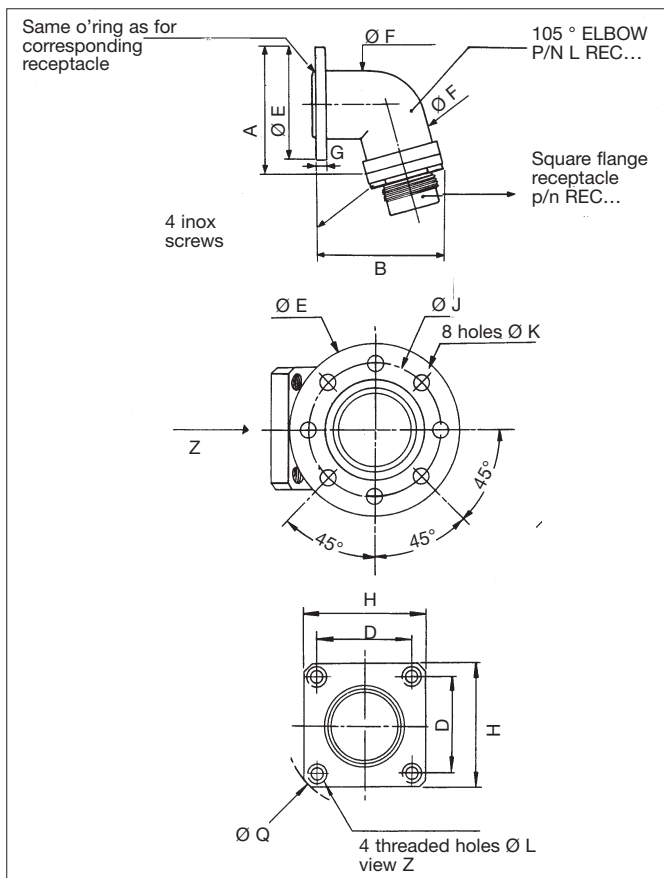

Shell sizes	A	B	D	E	F	G	H	J	K	L	Q	Part number
9 M	Please consult factory											
10 M	49 1.929	55 2.165	24 .945	42 1.654	24 .945	5 .197	32 1.260	34 1.339	4.2 .165	M 4	42.5 1.673	L-REC-10 M
14 M	58 2.283	66 2.598	31 1.220	53 2.087	33 1.299	6 .236	40 1.575	44 1.732	5.2 .205	M 5	53.5 2.106	L-REC-14 M
20 M	83 3.268	86 3.386	42 1.654	72 2.835	45 1.772	8 .315	52 2.047	59.5 2.343	6.3 .248	M 6	70.5 2.776	L-REC-20 M
24 M	122 4.803	123 4.843	60 2.362	102 4.016	60 2.362	9 .354	76 2.992	84.9 3.343	8.3 .327	M 8		L-REC-24 M

Mated connectors

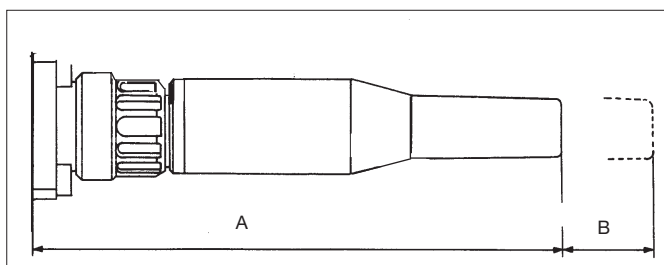

	Shell size	9 M (mm)	10 M (mm)	14 M (mm)	20 M (mm)	24 M (mm)
	Dimensions					
Single water-tightness version	A	84	115	150	195	315
	B	13	21	21	27	35
Double water-tightness version	A	-	-	193	283	315
	B	-	-	21	27	35

Inside diameters and part numbers of protection boots

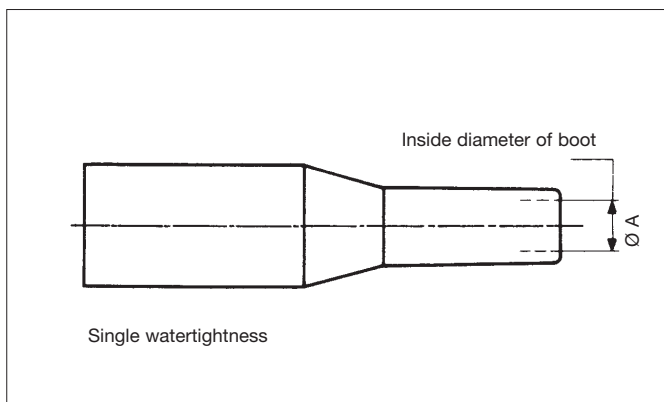

Shell size	Ø Cable	FOR OTHER DIAMETERS PLEASE CONSULT US			
9 M	4 to 6.2 .157 to .244				
	A	5 .197			
	P.N.	MDP 9 M 050			
10 M	6 to 7 .236 to .276	7 to 8.5 .276 to .335	8.5 to 10 .335 to .394	10 to 13 .394 to .512	
	A	5 .197	6.8 .268	8.5 .335	10 .394
	P.N.	MDP 10 M 050	MDP 10 M 068	MDP 10 M 085	MDP 10 M 100
14 M	9 to 11 .354 to .433	11 to 13 .433 to .512	13 to 15 .512 to .591	15 to 16 .591 to .630	
	A	9 .354	11 .433	13 .512	15 .591
	P.N.	MDP 14 M 090	MDP 14 M 110	MDP 14 M 130	MDP 14 M 150
20 M	16 to 19 .630 to .748	19 to 23 .748 to .906	23 to 25 .906 to .984	25 to 26 .984 to 1.024	
	A	16 .630	19 .748	22 .866	25 .984
	P.N.	MDP 20 M 160	MDP 20 M 190	MDP 20 M 220	MDP 20 M 250
24 M	20 to 24 .787 to .945	24 to 27 .945 to 1.063	27 to 28 1.063 to 1.102	28 to 29 1.102 to 1.142	29 to 31 1.142 to 1.220
	A	20 .787	23 .906	26 1.024	27.5 1.083
	P.N.	MDP 24 M 200	MDP 24 M 230	MDP 24 M 260	MDP 24 M 275

M Series



Mated connectors with 105° elbow mounting

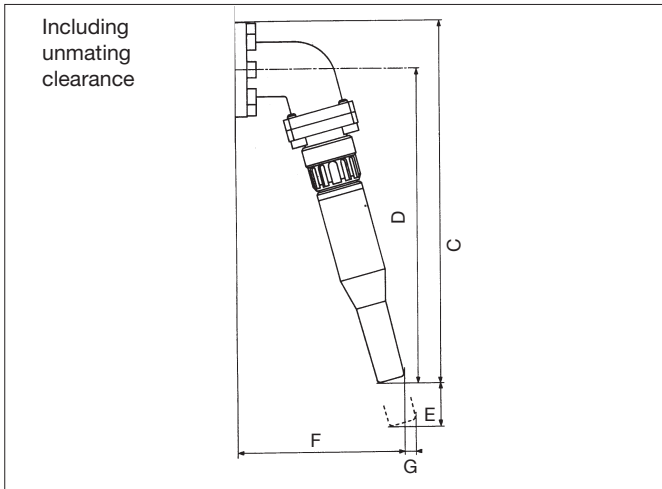

	Shell size	C	D	E	F	G
Single watertightness version	9 M	Please consult factory				
	10 M	150 5.906	134 5.276	18.5 .728	68 2.677	5 .197
	14 M	194 7.638	174 6.850	18.5 .728	84 3.307	5 .197
	20 M	256 10.079	230 9.055	25 .984	110 4.331	7 .276
	24 M	403 15.866	365 14.370	32 1.260	166 6.35	9 .354
Double watertightness version	14 M	236 9.291	216 8.504	18.5 .728	92 3.622	5 .197
	20 M	323 12.717	297 11.693	25 .984	128 5.039	7 .276
	24 M	423 16.654	385 15.157	32 1.260	171 6.732	9 .354

Cable clamping accessories

	PART NUMBER	DESCRIPTION	9 M	10 M	14 M	20 M	24 M
SINGLE WATERTIGHTNESS	A	Standard cable clamp without grounding or armor crimping	Ø 4 to 6.2 .157 to 0.244	Ø 5 to 11 .197 to .244	Ø 9 to 16 .354 to .433	Ø 16 to 26 .630 to 1.024	Ø 20 to 31 .787 to 1.220
	B	Standard cable clamp with grounding or armor crimping	Ø 6.2 .244	Ø 5 to 11 .197 to .433	Ø 9 to 16 .354 to .630		
	D	Crimp spacing sleeve for multipin insert with grounding or armor crimping		Ø 11 to 13 .433 to .512			
	E	Cable clamping sleeve with ligarex and grounding or armor crimping		O.D. 9.2/.362 O.D. 10.8/.425 O.D. 11.8/.465			
	G	Cable clamping sleeve with 2 half collars with grounding or armor crimping				O.D. 16 to 20 .630 to .787	
	H	Cable clamp for coaxial cable		RG 59 BU RG 213 U RG 11 AU	O.D. 16 .630		
	J	Cable clamp for triaxial cable		consult us	consult us		
	K	Cable clamp for high voltage		O.D. 11.5 .453 DSM 40	O.D. 14 0.551 DSM 41	O.D. 18.5 0.728 DSM 37	
	L	Outside cable clamping sleeve with 2 shifted half collars without grounding and armor crimping					Ø Max. 31 1.220
	M	Outside cable clamping sleeve with 2 shifted half collars with grounding or armor crimping			O.D. 9 to 14 .354 to .551		Ø Max. 31 1.220
DOUBLE WATERTIGHTNESS	P	Cable clamp with grounding or armor crimping			O.D. 16 .630	O.D. 22 .866	O.D. 28.5 1.122
	S	Cable clamp without grounding nor armor crimping			O.D. 16 .630	O.D. 22 .866	O.D. 28.5 1.122