

1,048,576 WORD x 4 BIT DYNAMIC RAM

**PRELIMINARY**

**DESCRIPTION**

The TC514400AP/AJ/ASJ/AZ is the new generation dynamic RAM organized 1,048,576 words by 4 bits. The TC514400AP/AJ/ASJ/AZ utilizes TOSHIBA's CMOS Silicon gate process technology as well as advanced circuit techniques to provide wide operating margins, both internally and to the system user. Multiplexed address inputs permit the TC514400AP/AJ/ASJ/AZ to be packaged in a standard 20 pin plastic DIP, 26/20 pin plastic SOJ (300/350mil) and 20 pin plastic ZIP. The package size provides high system bit densities and is compatible with widely available automated testing and insertion equipment. System oriented features include single power supply of  $5V \pm 10\%$  tolerance, direct interfacing capability with high performance logic families such as Schottky TTL.

**FEATURES**

- 1,048,576 word by 4 bit organization
- Fast access time and cycle time

TC514400AP/AJ/ASJ/AZ - 70/ - 80/ - 10				
$t_{RAC}$	RAS Access Time	70ns	80ns	100ns
$t_{AA}$	Column Address Access Time	35ns	40ns	50ns
$t_{CAC}$	CAS Access Time	20ns	20ns	25ns
$t_{RC}$	Cycle Time	130ns	150ns	180ns
$t_{PC}$	Fast Page Mode Cycle Time	45ns	50ns	60ns

- Single power supply of  $5V \pm 10\%$  with a built-in VBB generator

**PIN NAMES**

Symbol	Function	Symbol	Function
A0~A9	Address Inputs	OE	Output Enable
RAS	Row Address Strobe	I/O1~I/O4	Data input/Output
CAS	Column Address Strobe	V <sub>CC</sub>	Power (+5V)
WRITE	Read/Write Input	V <sub>SS</sub>	Ground

- Low Power
  - 550mW MAX. Operating (TC514400AP/AJ/ASJ/AZ - 70)
  - 468mW MAX. Operating (TC514400AP/AJ/ASJ/AZ - 80)
  - 413mW MAX. Operating (TC514400AP/AJ/ASJ/AZ - 10)
  - 5.5mW MAX. Standby
- Outputs unlatched at cycle end allows two-dimensional chip selection
- Read-Modify-Write, CAS before RAS refresh, RAS-only refresh, Hidden refresh, Fast Page Mode and Test Mode capability
- All inputs and outputs TTL compatible
- 1024 refresh cycles/16ms
- Package
  - TC514400AP : DIP20-P-300C
  - TC514400AJ : SOJ26-P-350
  - TC514400ASJ : SOJ26-P-300A
  - TC514400AZ : ZIP20-P-400A

**PIN CONNECTION (TOP VIEW)**

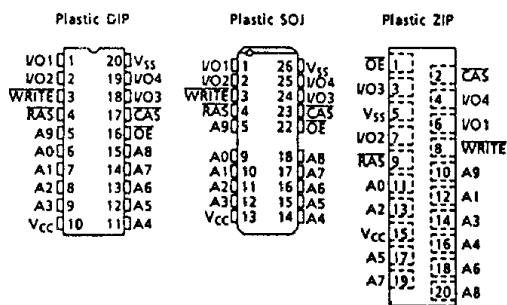

**BLOCK DIAGRAM**

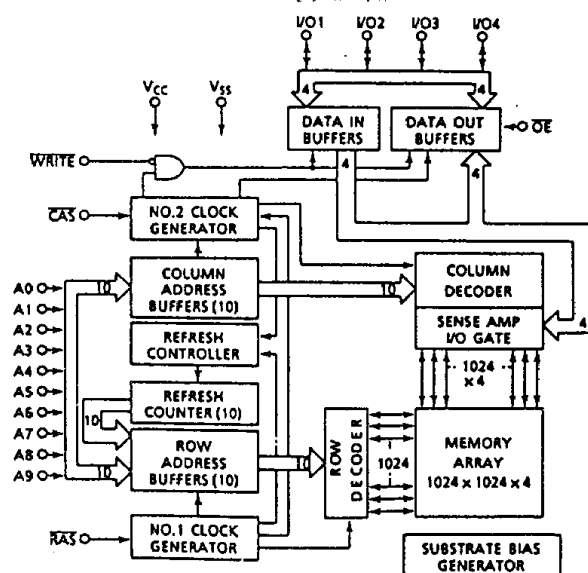

# TC514400AP/AJ/ASJ/AZ-70, TC514400AP/AJ/ASJ/AZ-80 TC514400AP/AJ/ASJ/AZ-10

## ABSOLUTE MAXIMUM RATINGS

ITEM	SYMBOL	RATING	UNITS	NOTES
Input Voltage	$V_{IN}$	-1~7	V	1
Output Voltage	$V_{OUT}$	-1~7	V	1
Power Supply Voltage	$V_{CC}$	-1~7	V	1
Operating Temperature	$T_{OPR}$	0~70	°C	1
Storage Temperature	$T_{STG}$	-55~150	°C	1
Soldering Temperature · Time	$T_{SOLDER}$	260 · 10	°C · sec	1
Power Dissipation	$P_D$	700	mW	1
Short Circuit Output Current	$I_{OUT}$	50	mA	1

## RECOMMENDED DC OPERATING CONDITIONS ( $T_a = 0\sim 70^\circ\text{C}$ )

SYMBOL	PARAMETER	MIN.	TYP.	MAX.	UNIT	NOTES
$V_{CC}$	Supply Voltage	4.5	5.0	5.5	V	2
$V_{IH}$	Input High Voltage	2.4	-	6.5	V	2
$V_{IL}$	Input Low Voltage	-1.0	-	0.8	V	2

# TC514400AP/AJ/ASJ/AZ-70, TC514400AP/AJ/ASJ/AZ-80 TC514400AP/AJ/ASJ/AZ-10

## DC ELECTRICAL CHARACTERISTICS ( $V_{CC} = 5V \pm 10\%$ , $T_a = 0 \sim 70^\circ\text{C}$ )

SYMBOL	PARAMETER	MIN.	MAX.	UNITS	NOTES	
I <sub>CC1</sub>	OPERATING CURRENT					
	Average Power Supply Operating Current ( $\overline{RAS}$ , $\overline{CAS}$ , Address Cycling: $t_{RC} = t_{RC}$ MIN.)	TC514400AP/AJ/ASJ/AZ-70	-	100	mA	3, 4
		TC514400AP/AJ/ASJ/AZ-80	-	85		5
	TC514400AP/AJ/ASJ/AZ-10	-	75			
I <sub>CC2</sub>	STANDBY CURRENT Power Supply Standby Current ( $\overline{RAS} = \overline{CAS} = V_{IH}$ )	-	2	mA		
I <sub>CC3</sub>	$\overline{RAS}$ ONLY REFRESH CURRENT					
	Average Power Supply Current, $\overline{RAS}$ Only Mode ( $\overline{RAS}$ Cycling, $\overline{CAS} = V_{IH}$ ; $t_{RC} = t_{RC}$ MIN.)	TC514400AP/AJ/ASJ/AZ-70	-	100	mA	3, 5
		TC514400AP/AJ/ASJ/AZ-80	-	85		
	TC514400AP/AJ/ASJ/AZ-10	-	75			
I <sub>CC4</sub>	FAST PAGE MODE CURRENT					
	Average Power Supply Current, Fast Page Mode ( $\overline{RAS} = V_{IL}$ , $\overline{CAS}$ , Address Cycling: $t_{PC} = t_{PC}$ MIN.)	TC514400AP/AJ/ASJ/AZ-70	-	70	mA	3, 4 5
		TC514400AP/AJ/ASJ/AZ-80	-	60		
	TC514400AP/AJ/ASJ/AZ-10	-	55			
I <sub>CC5</sub>	STANDBY CURRENT Power Supply Standby Current ( $\overline{RAS} = \overline{CAS} = V_{CC} - 0.2V$ )	-	1	mA		
I <sub>CC6</sub>	$\overline{CAS}$ BEFORE $\overline{RAS}$ REFRESH CURRENT					
	Average Power Supply Current, $\overline{CAS}$ Before $\overline{RAS}$ Mode ( $\overline{RAS}$ , $\overline{CAS}$ Cycling: $t_{RC} = t_{RC}$ MIN.)	TC514400AP/AJ/ASJ/AZ-70	-	100	mA	3, 5
		TC514400AP/AJ/ASJ/AZ-80	-	85		
	TC514400AP/AJ/ASJ/AZ-10	-	75			
I <sub>I (L)</sub>	INPUT LEAKAGE CURRENT Input Leakage Current, any input ( $0V \leq V_{IN} \leq 6.5V$ , All Other Pins Not Under Test = $0V$ )	- 10	10	$\mu\text{A}$		
I <sub>O (L)</sub>	OUTPUT LEAKAGE CURRENT ( $D_{OUT}$ is disabled, $0V \leq V_{OUT} \leq 5.5V$ )	- 10	10	$\mu\text{A}$		
V <sub>OH</sub>	OUTPUT LEVEL Output "H" Level Voltage ( $I_{OUT} = -5\text{mA}$ )	2.4	-	V		
V <sub>OL</sub>	OUTPUT LEVEL Output "L" Level Voltage ( $I_{OUT} = 4.2\text{mA}$ )	-	0.4	V		

# TC514400AP/AJ/ASJ/AZ-70, TC514400AP/AJ/ASJ/AZ-80 TC514400AP/AJ/ASJ/AZ-10

## ELECTRICAL CHARACTERISTICS AND RECOMMENDED AC OPERATING CONDITIONS

( $V_{CC} = 5V \pm 10\%$ ,  $T_a = 0 \sim 70^\circ\text{C}$ ) (Notes 6, 7, 8)

SYMBOL	PARAMETER	TC514400AP/ AJ/ASJ/AZ-70		TC514400AP/ AJ/ASJ/AZ-80		TC514400AP/ AJ/ASJ/AZ-10		UNIT	NOTES
		MIN.	MAX.	MIN.	MAX.	MIN.	MAX.		
$t_{RC}$	Random Read or Write Cycle Time	130	-	150	-	180	-	ns	
$t_{RMW}$	Read-Modify-Write Cycle Time	185	-	205	-	245	-	ns	
$t_{PC}$	Fast Page Mode Cycle Time	45	-	50	-	60	-	ns	
$t_{PRMW}$	Fast Page Mode Read-Modify-Write Cycle Time	100	-	105	-	125	-	ns	
$t_{RAC}$	Access Time from $\overline{RAS}$	-	70	-	80	-	100	ns	9,14 15
$t_{CAC}$	Access Time from $\overline{CAS}$	-	20	-	20	-	25	ns	9,14
$t_{AA}$	Access Time from Column Address	-	35	-	40	-	50	ns	9,15
$t_{CPA}$	Access Time from $\overline{CAS}$ Precharge	-	40	-	45	-	55	ns	9
$t_{CLZ}$	$\overline{CAS}$ to output in Low-Z	0	-	0	-	0	-	ns	9
$t_{OFF}$	Output Buffer Turn-off Delay	0	20	0	20	0	20	ns	10
$t_T$	Transition Time (Rise and Fall)	3	50	3	50	3	50	ns	8
$t_{RP}$	$\overline{RAS}$ Precharge Time	50	-	60	-	70	-	ns	
$t_{RAS}$	$\overline{RAS}$ Pulse Width	70	10,000	80	10,000	100	10,000	ns	
$t_{RASP}$	$\overline{RAS}$ Pulse Width (Fast Page Mode)	70	200,000	80	200,000	100	200,000	ns	
$t_{RSH}$	$\overline{RAS}$ Hold Time	20	-	20	-	25	-	ns	
$t_{RHCP}$	$\overline{RAS}$ Hold Time From $\overline{CAS}$ Precharge (Fast Page Mode)	40	-	45	-	55	-	ns	
$t_{CSH}$	$\overline{CAS}$ Hold Time	70	-	80	-	100	-	ns	
$t_{CAS}$	$\overline{CAS}$ Pulse Width	20	10,000	20	10,000	25	10,000	ns	
$t_{RCD}$	$\overline{RAS}$ to $\overline{CAS}$ Delay Time	20	50	20	60	25	75	ns	14
$t_{RAD}$	$\overline{RAS}$ to Column Address Delay Time	15	35	15	40	20	50	ns	15
$t_{CRP}$	$\overline{CAS}$ to $\overline{RAS}$ Precharge Time	5	-	5	-	10	-	ns	
$t_{CP}$	$\overline{CAS}$ Precharge Time	10	-	10	-	10	-	ns	
$t_{ASR}$	Row Address Set-Up Time	0	-	0	-	0	-	ns	
$t_{RAH}$	Row Address Hold Time	10	-	10	-	15	-	ns	
$t_{ASC}$	Column Address Set-Up Time	0	-	0	-	0	-	ns	
$t_{CAH}$	Column Address Hold Time	15	-	15	-	20	-	ns	
$t_{RAL}$	Column Address to $\overline{RAS}$ Lead Time	35	-	40	-	50	-	ns	
$t_{RCS}$	Read Command Set-Up Time	0	-	0	-	0	-	ns	
$t_{RCH}$	Read Command Hold Time	0	-	0	-	0	-	ns	11

# TC514400AP/AJ/ASJ/AZ-70, TC514400AP/AJ/ASJ/AZ-80 TC514400AP/AJ/ASJ/AZ-10

## ELECTRICAL CHARACTERISTICS AND RECOMMENDED AC OPERATING CONDITIONS (Continued)

SYMBOL	PARAMETER	TC514400AP/ AJ/ASJ/AZ-70		TC514400AP/ AJ/ASJ/AZ-80		TC514400AP/ AJ/ASJ/AZ-10		UNITS	NOTES
		MIN.	MAX.	MIN.	MAX.	MIN.	MAX.		
t <sub>RRH</sub>	Read Command Hold Time referenced to $\overline{RAS}$	0	-	0	-	0	-	ns	11
t <sub>WCH</sub>	Write Command Hold Time	15	-	15	-	20	-	ns	
t <sub>WP</sub>	Write Command Pulse Width	15	-	15	-	20	-	ns	
t <sub>RWL</sub>	Write Command to $\overline{RAS}$ Lead Time	20	-	20	-	25	-	ns	
t <sub>CWL</sub>	Write Command to $\overline{CAS}$ Lead Time	20	-	20	-	25	-	ns	
t <sub>DS</sub>	Data Set-Up Time	0	-	0	-	0	-	ns	12
t <sub>DH</sub>	Data Hold Time	15	-	15	-	20	-	ns	12
t <sub>REF</sub>	Refresh Period	-	16	-	16	-	16	ms	
t <sub>WCS</sub>	Write Command Set-Up Time	0	-	0	-	0	-	ns	13
t <sub>CWD</sub>	$\overline{CAS}$ to WRITE Delay Time	50	-	50	-	60	-	ns	13
t <sub>RWD</sub>	$\overline{RAS}$ to WRITE Delay Time	100	-	110	-	135	-	ns	13
t <sub>AWD</sub>	Column Address to WRITE Delay Time	65	-	70	-	85	-	ns	13
t <sub>CPWD</sub>	$\overline{CAS}$ Precharge to WRITE Delay Time	70	-	75	-	90	-	ns	13
t <sub>CSR</sub>	$\overline{CAS}$ Set-Up Time ( $\overline{CAS}$ before $\overline{RAS}$ Cycle)	5	-	5	-	5	-	ns	
t <sub>CHR</sub>	$\overline{CAS}$ Hold Time ( $\overline{CAS}$ before $\overline{RAS}$ Cycle)	15	-	15	-	20	-	ns	
t <sub>RPC</sub>	$\overline{RAS}$ to $\overline{CAS}$ Precharge Time	0	-	0	-	0	-	ns	
t <sub>CPT</sub>	$\overline{CAS}$ Precharge Time ( $\overline{CAS}$ before $\overline{RAS}$ Counter Test Cycle)	40	-	40	-	50	-	ns	
t <sub>ROH</sub>	$\overline{RAS}$ Hold Time referenced to $\overline{OE}$	10	-	10	-	20	-	ns	
t <sub>OEa</sub>	$\overline{OE}$ Access Time	-	20	-	20	-	25	ns	
t <sub>oED</sub>	$\overline{OE}$ to Data Delay	20	-	20	-	25	-	ns	
t <sub>oEZ</sub>	Output buffer turn off Delay Time from $\overline{OE}$	0	20	0	20	0	20	ns	10
t <sub>oEH</sub>	$\overline{OE}$ Command Hold Time	20	-	20	-	25	-	ns	
t <sub>WTS</sub>	Write Command Set-Up Time (Test Mode In)	10	-	10	-	10	-	ns	
t <sub>WTH</sub>	Write Command Hold Time (Test Mode In)	10	-	10	-	10	-	ns	
t <sub>WRP</sub>	WRITE to $\overline{RAS}$ Precharge Time ( $\overline{CAS}$ before $\overline{RAS}$ Cycle)	10	-	10	-	10	-	ns	
t <sub>WRH</sub>	WRITE to $\overline{RAS}$ Hold Time ( $\overline{CAS}$ before $\overline{RAS}$ Cycle)	10	-	10	-	10	-	ns	

# TC514400AP/AJ/ASJ/AZ-70, TC514400AP/AJ/ASJ/AZ-80 TC514400AP/AJ/ASJ/AZ-10

## ELECTRICAL CHARACTERISTICS AND RECOMMENDED AC OPERATING CONDITIONS IN THE TEST MODE

SYMBOL	PARAMETER	TC514400AP/ AJ/ASJ/AZ-70		TC514400AP/ AJ/ASJ/AZ-80		TC514400AP/ AJ/ASJ/AZ-10		UNITS	NOTES
		MIN.	MAX.	MIN.	MAX.	MIN.	MAX.		
t <sub>RC</sub>	Random Read or Write Cycle Time	135	-	155	-	185	-	ns	
t <sub>RMW</sub>	Read-Modify-Write Cycle Time	190	-	210	-	250	-	ns	
t <sub>PC</sub>	Fast Page Mode Cycle Time	50	-	55	-	65	-	ns	
t <sub>PRMW</sub>	Fast Page Mode Cycle Read-Modify-Write Time	105	-	110	-	130	-	ns	
t <sub>RAC</sub>	Access Time from $\overline{RAS}$	-	75	-	85	-	105	ns	9,14,15
t <sub>CAC</sub>	Access Time from $\overline{CAS}$	-	25	-	25	-	30	ns	9,14
t <sub>AA</sub>	Access Time from Column Address	-	40	-	45	-	55	ns	9,15
t <sub>CPA</sub>	Access Time from $\overline{CAS}$ Precharge	-	45	-	50	-	60	ns	9
t <sub>RAS</sub>	$\overline{RAS}$ Pulse Width	75	10,000	85	10,000	105	10,000	ns	
t <sub>RASP</sub>	$\overline{RAS}$ Pulse Width (Fast Page Mode)	75	200,000	85	200,000	105	200,000	ns	
t <sub>RSH</sub>	$\overline{RAS}$ Hold Time	25	-	25	-	30	-	ns	
t <sub>CSH</sub>	$\overline{CAS}$ Hold Time	75	-	85	-	105	-	ns	
t <sub>RHCP</sub>	$\overline{CAS}$ Precharge to $\overline{RAS}$ Hold Time	45	-	50	-	60	-	ns	
t <sub>CAS</sub>	$\overline{CAS}$ Pulse Width	25	10,000	25	10,000	30	10,000	ns	
t <sub>RAL</sub>	Column Address to $\overline{RAS}$ Lead Time	40	-	45	-	55	-	ns	
t <sub>CWD</sub>	$\overline{CAS}$ to $\overline{WRITE}$ Delay Time	55	-	55	-	65	-	ns	13
t <sub>RWD</sub>	$\overline{RAS}$ to $\overline{WRITE}$ Delay Time	105	-	115	-	140	-	ns	13
t <sub>AWD</sub>	Column Address to $\overline{WRITE}$ Delay Time	70	-	75	-	90	-	ns	13
t <sub>CPWD</sub>	$\overline{CAS}$ Precharge to $\overline{WRITE}$ Delay Time	75	-	80	-	95	-	ns	13
t <sub>OEA</sub>	$\overline{OE}$ Access Time	-	25	-	25	-	30	ns	
t <sub>OEH</sub>	$\overline{OE}$ Command Hold Time	25	-	25	-	30	-	ns	

## CAPACITANCE ( $V_{CC} = 5V \pm 10\%$ , $f = 1MHz$ , $T_a = 0 \sim 70^\circ C$ )

SYMBOL	PARAMETER	MIN.	MAX.	UNIT
C <sub>I1</sub>	Input Capacitance (A0~A9)	-	5	pF
C <sub>I2</sub>	Input Capacitance ( $\overline{RAS}$ , $\overline{CAS}$ , $\overline{WRITE}$ , $\overline{OE}$ )	-	7	pF
C <sub>O</sub>	Input/Output Capacitance (I/O1~I/O4)	-	7	pF

# TC514400AP/AJ/ASJ/AZ-70, TC514400AP/AJ/ASJ/AZ-80 TC514400AP/AJ/ASJ/AZ-10

## NOTES:

1. Stresses greater than those listed under "Absolute Maximum Ratings" may cause permanent damage to the device.
2. All voltages are referenced to  $V_{SS}$ .
3.  $I_{CC1}$ ,  $I_{CC3}$ ,  $I_{CC4}$ ,  $I_{CC6}$  depend on cycle rate.
4.  $I_{CC1}$ ,  $I_{CC4}$  depend on output loading. Specified values are obtained with the output open.
5. Column address can be changed once or less while  $\overline{RAS}=V_{IL}$  and  $\overline{CAS}=V_{IH}$ .
6. An initial pause of 200 $\mu$ s is required after power-up followed by 8  $\overline{RAS}$  only refresh cycles before proper device operation is achieved. In case of using internal refresh counter, a minimum of 8  $\overline{CAS}$  before  $\overline{RAS}$  refresh cycles instead of 8  $\overline{RAS}$  only refresh cycles are required.
7. AC measurements assume  $t_r=5$ ns.
8.  $V_{IH}$  (min.) and  $V_{IL}$  (max.) are reference levels for measuring timing of input signals. Also, transition times are measured between  $V_{IH}$  and  $V_{IL}$ .
9. Measured with a load equivalent to 2 TTL loads and 100pF.
10.  $t_{OFF}$  (max.) and  $t_{OEZ}$  (max.) define the time at which the output achieves the open circuit condition and are not referenced to output voltage levels.
11. Either  $t_{RCH}$  or  $t_{RRH}$  must be satisfied for a read cycle.
12. These parameters are referenced to  $\overline{CAS}$  leading edge in early write cycles and to  $\overline{WRITE}$  leading edge in Read-Modify-Write cycles.
13.  $t_{WCS}$ ,  $t_{RWd}$ ,  $t_{CWD}$ ,  $t_{AWd}$  and  $t_{CPWD}$  are not restrictive operating parameters. They are included in the data sheet as electrical characteristics only. If  $t_{WCS} \geq t_{WCS}(\text{min.})$ , the cycle is an early write cycle and the data out pin will remain open circuit (high impedance) through the entire cycle; If  $t_{RWd} \geq t_{RWd}(\text{min.})$ ,  $t_{CWD} \geq t_{CWD}(\text{min.})$ ,  $t_{AWd} \geq t_{AWd}(\text{min.})$  and  $t_{CPWD} \geq t_{CPWD}(\text{min.})$  (Fast Page Mode), the cycle is a Read-Modify-Write cycle and the data out will contain data read from the selected cell: If neither of the above sets of conditions is satisfied, the condition of the data out (at access time) is indeterminate.
14. Operation within the  $t_{RCD}(\text{max.})$  limit insures that  $t_{RAC}(\text{max.})$  can be met.  $t_{RCD}(\text{max.})$  is specified as a reference point only: If  $t_{RCD}$  is greater than the specified  $t_{RCD}(\text{max.})$  limit, then access time is controlled by  $t_{CAC}$ .
15. Operation within the  $t_{RAD}(\text{max.})$  limit insures that  $t_{RAC}(\text{max.})$  can be met.  $t_{RAD}(\text{max.})$  is specified as a reference point only: If  $t_{RAD}$  is greater than the specified  $t_{RAD}(\text{max.})$  limit, then access time is controlled by  $t_{AA}$ .

TC514400AP/AJ/ASJ/AZ-70, TC514400AP/AJ/ASJ/AZ-80  
 TC514400AP/AJ/ASJ/AZ-10

READ CYCLE

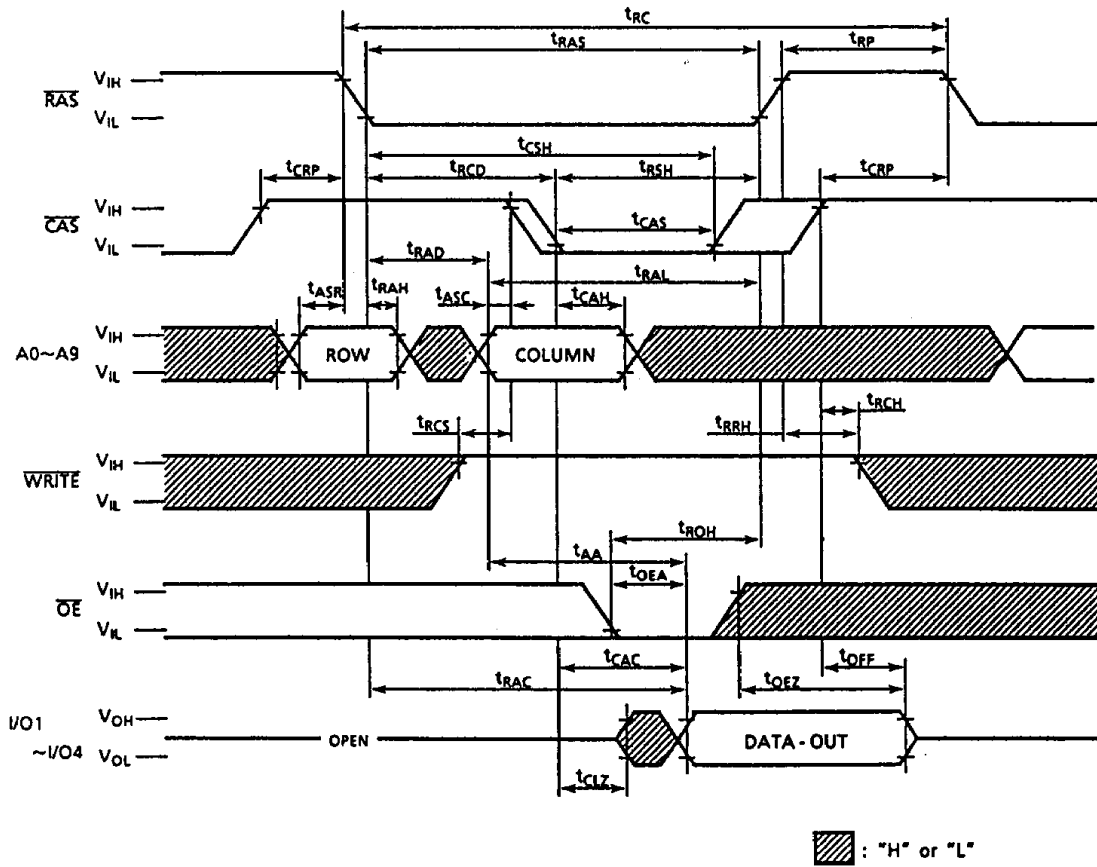





# TC514400AP/AJ/ASJ/AZ-70, TC514400AP/AJ/ASJ/AZ-80 TC514400AP/AJ/ASJ/AZ-10

## WRITE CYCLE (OE CONTROLLED WRITE)

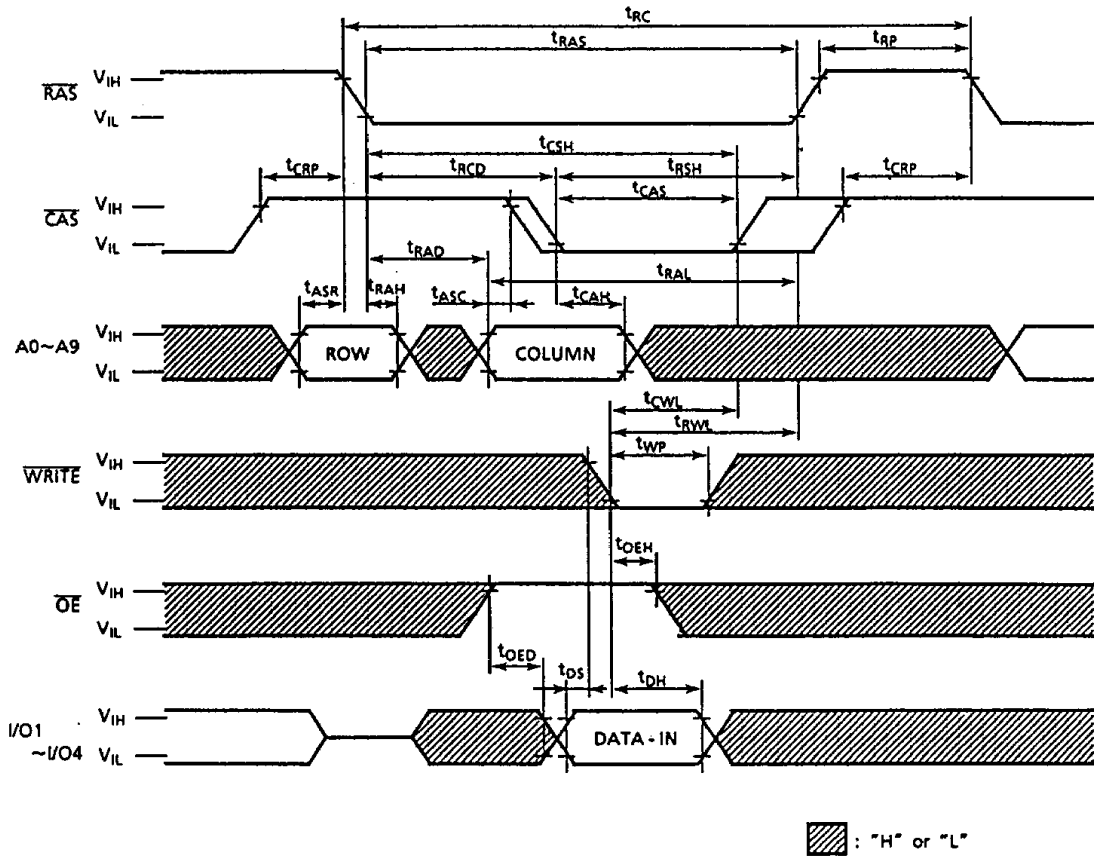

TC514400AP/AJ/ASJ/AZ-70, TC514400AP/AJ/ASJ/AZ-80  
 TC514400AP/AJ/ASJ/AZ-10

READ-MODIFY-WRITE CYCLE

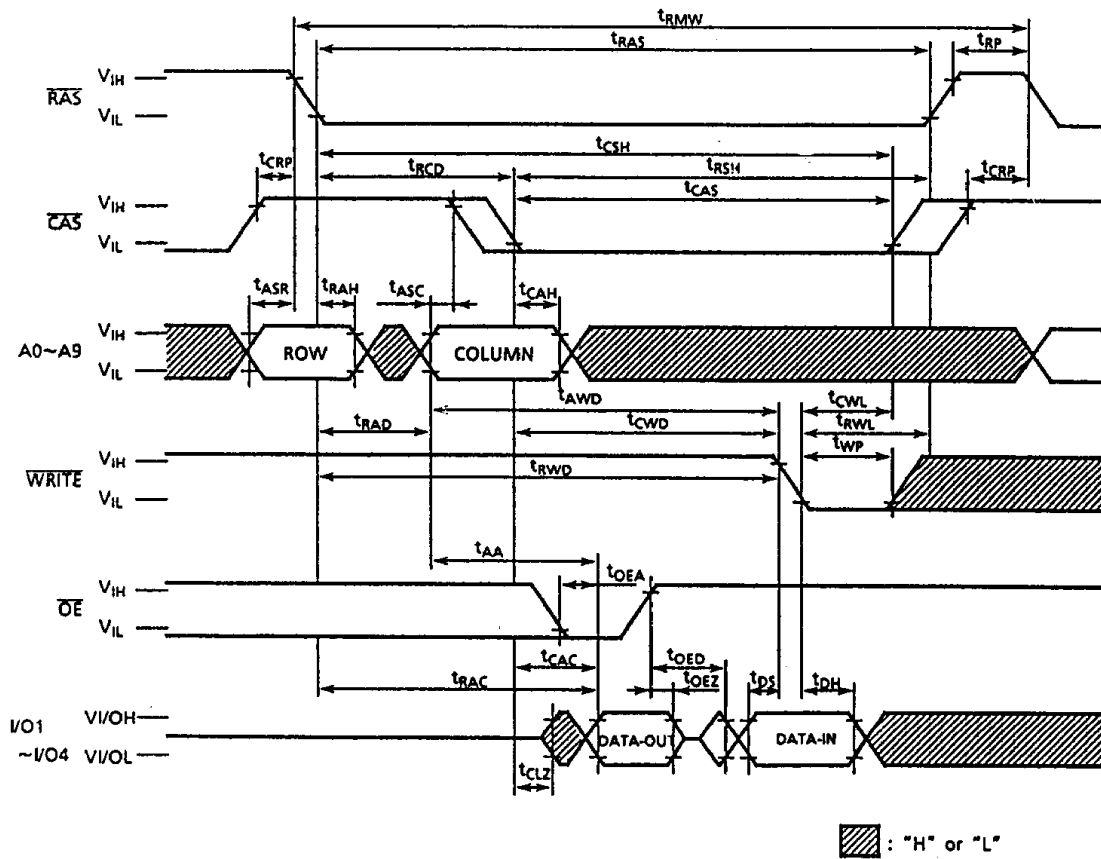

TC514400AP/AJ/ASJ/AZ-70, TC514400AP/AJ/ASJ/AZ-80  
 TC514400AP/AJ/ASJ/AZ-10

FAST PAGE MODE READ CYCLE

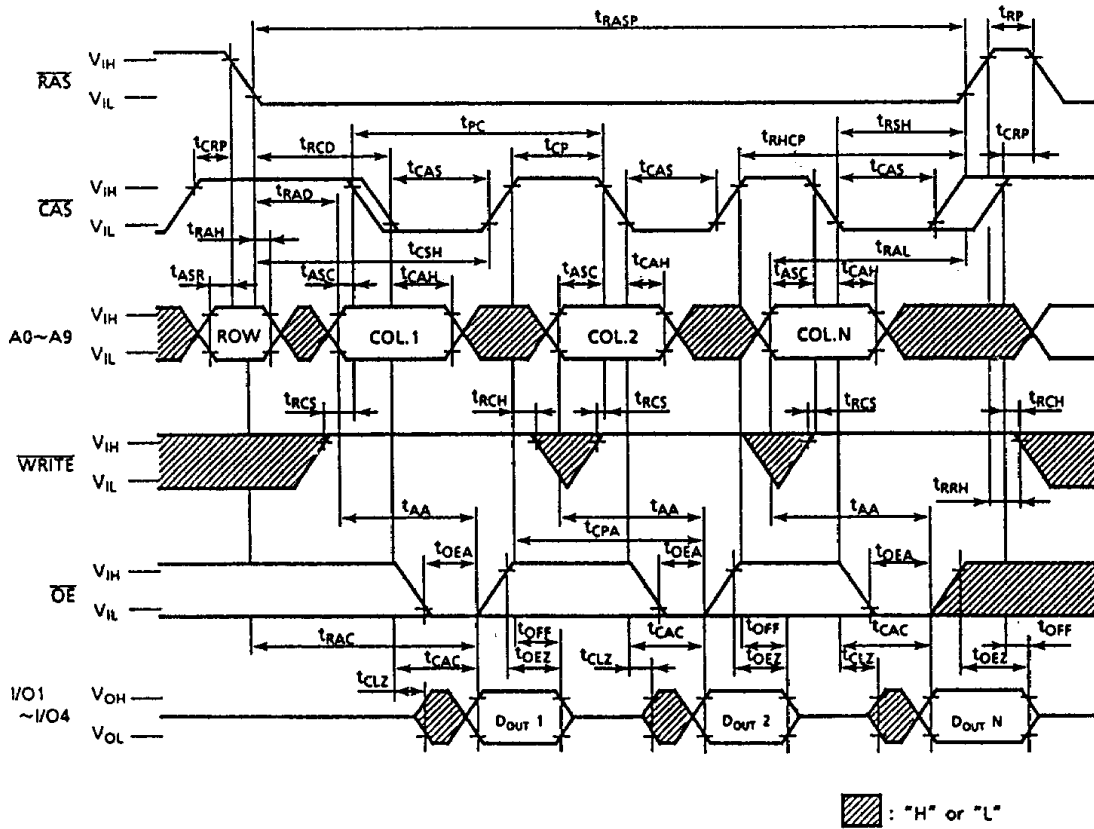



# TC514400AP/AJ/ASJ/AZ-70, TC514400AP/AJ/ASJ/AZ-80 TC514400AP/AJ/ASJ/AZ-10

## FAST PAGE MODE READ-MODIFY-WRITE CYCLE

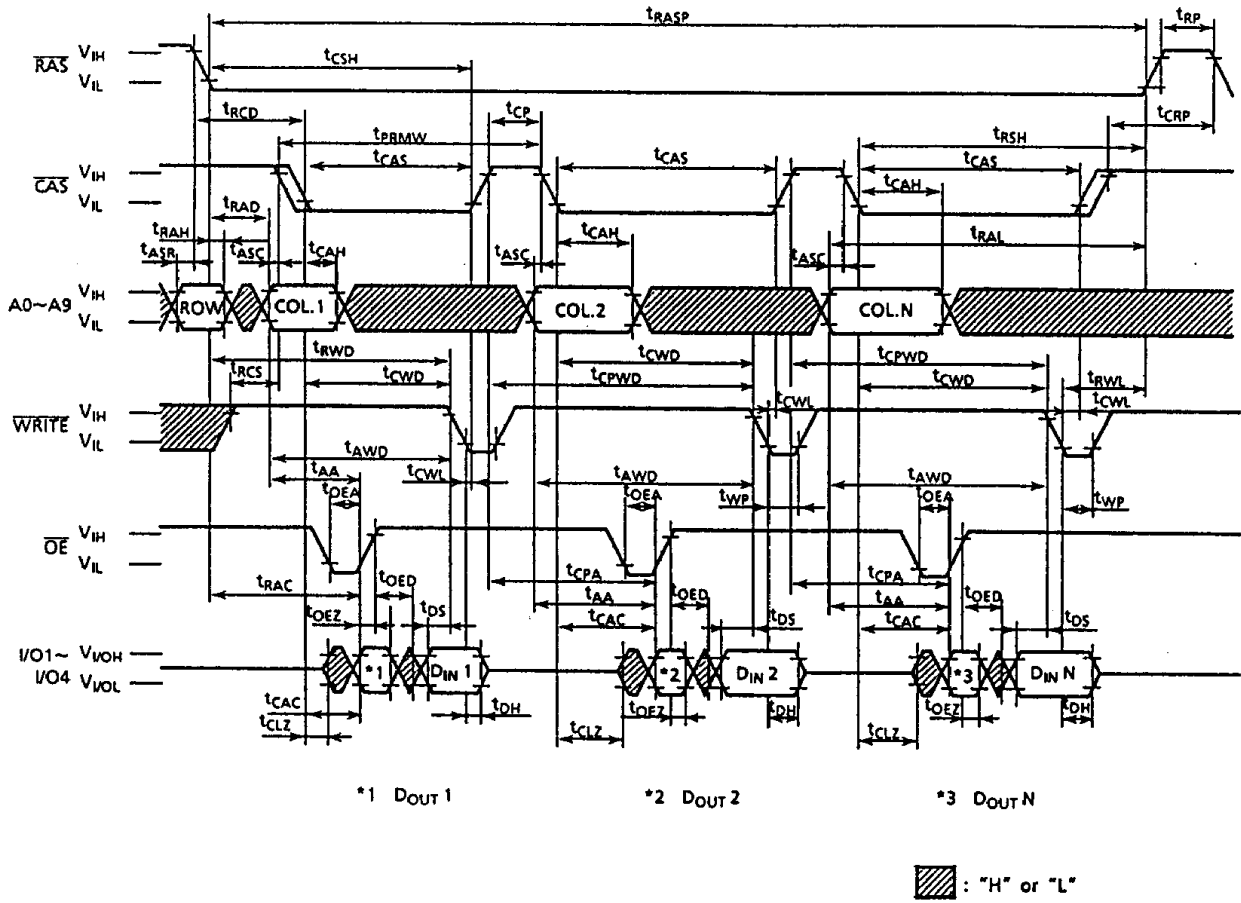

# TC514400AP/AJ/ASJ/AZ-70, TC514400AP/AJ/ASJ/AZ-80 TC514400AP/AJ/ASJ/AZ-10

## RAS ONLY REFRESH CYCLE

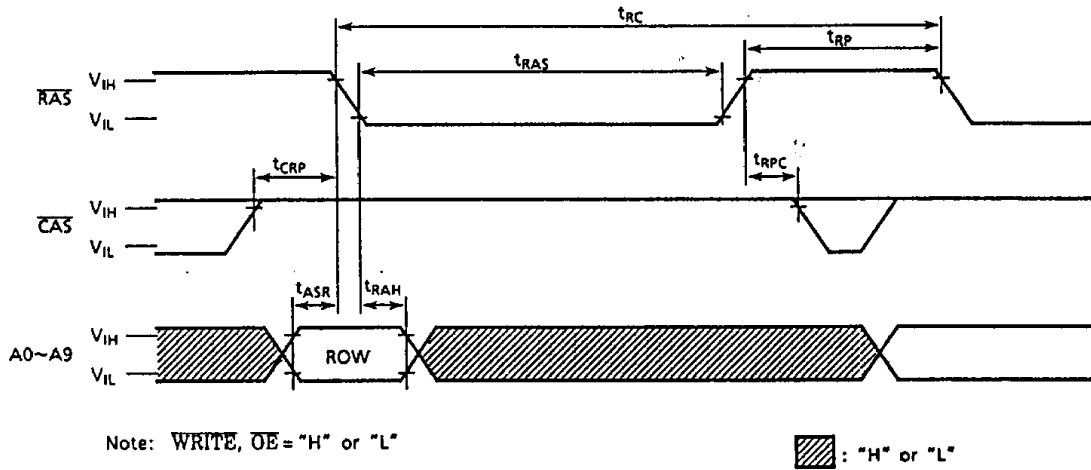

## CAS BEFORE RAS REFRESH CYCLE

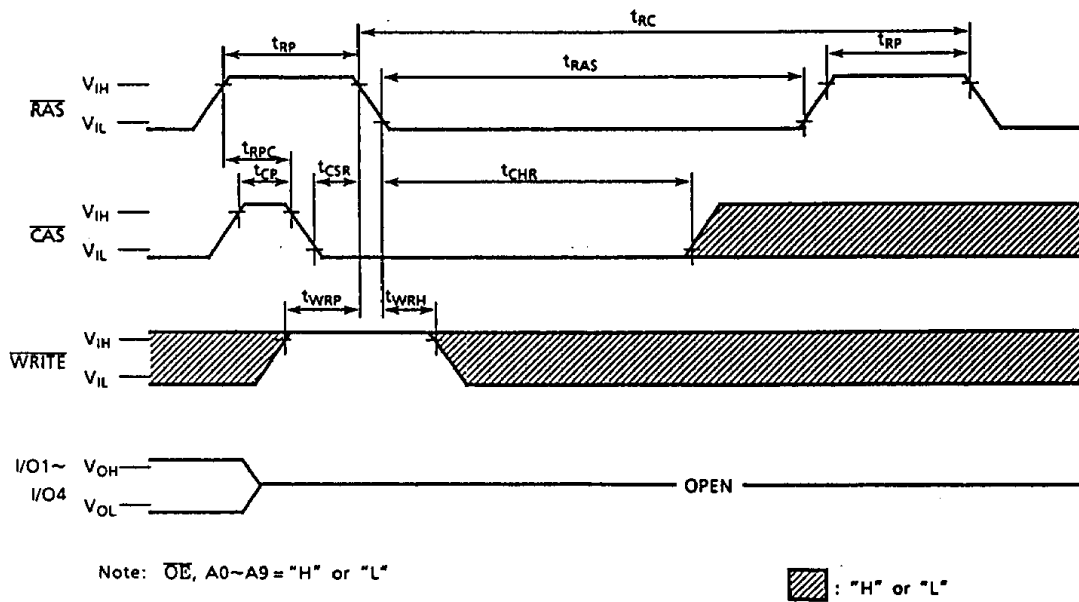

TC514400AP/AJ/ASJ/AZ-70, TC514400AP/AJ/ASJ/AZ-80  
 TC514400AP/AJ/ASJ/AZ-10

HIDDEN REFRESH CYCLE (READ)

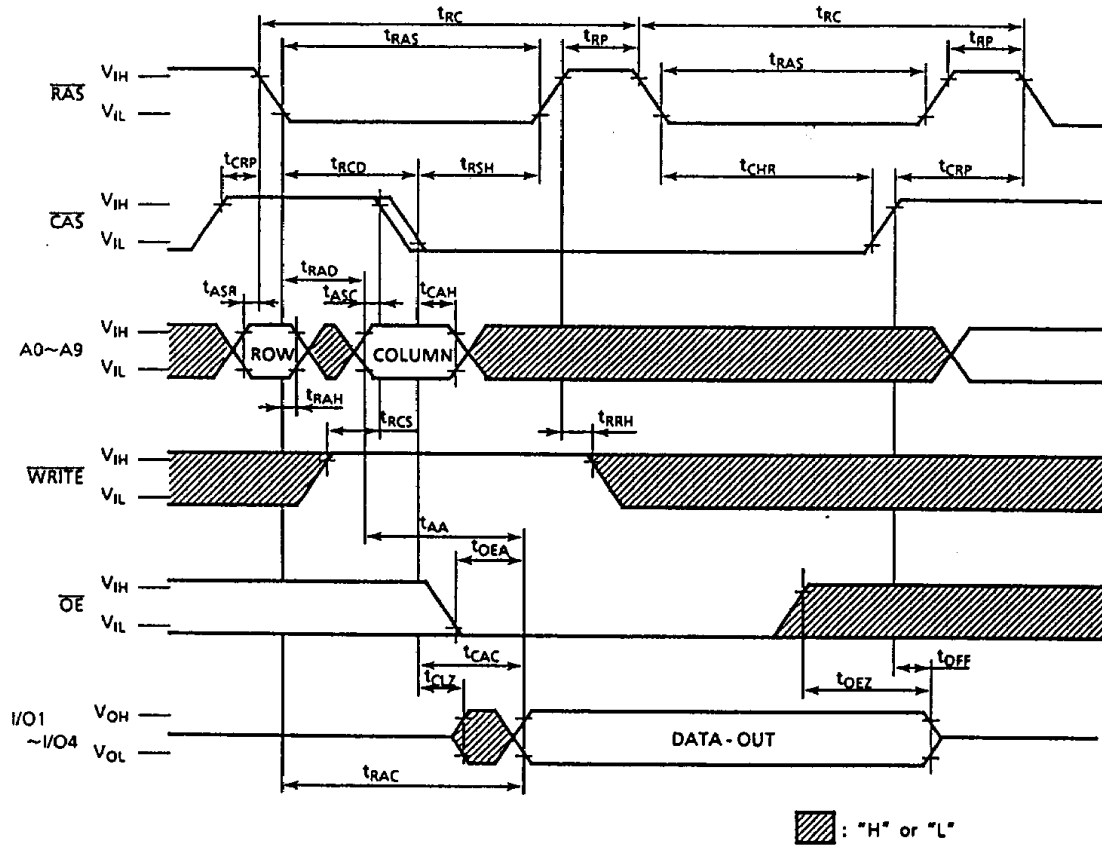



TC514400AP/AJ/ASJ/AZ-70, TC514400AP/AJ/ASJ/AZ-80  
 TC514400AP/AJ/ASJ/AZ-10

HIDDEN REEFRESH CYCLE (WRITE)

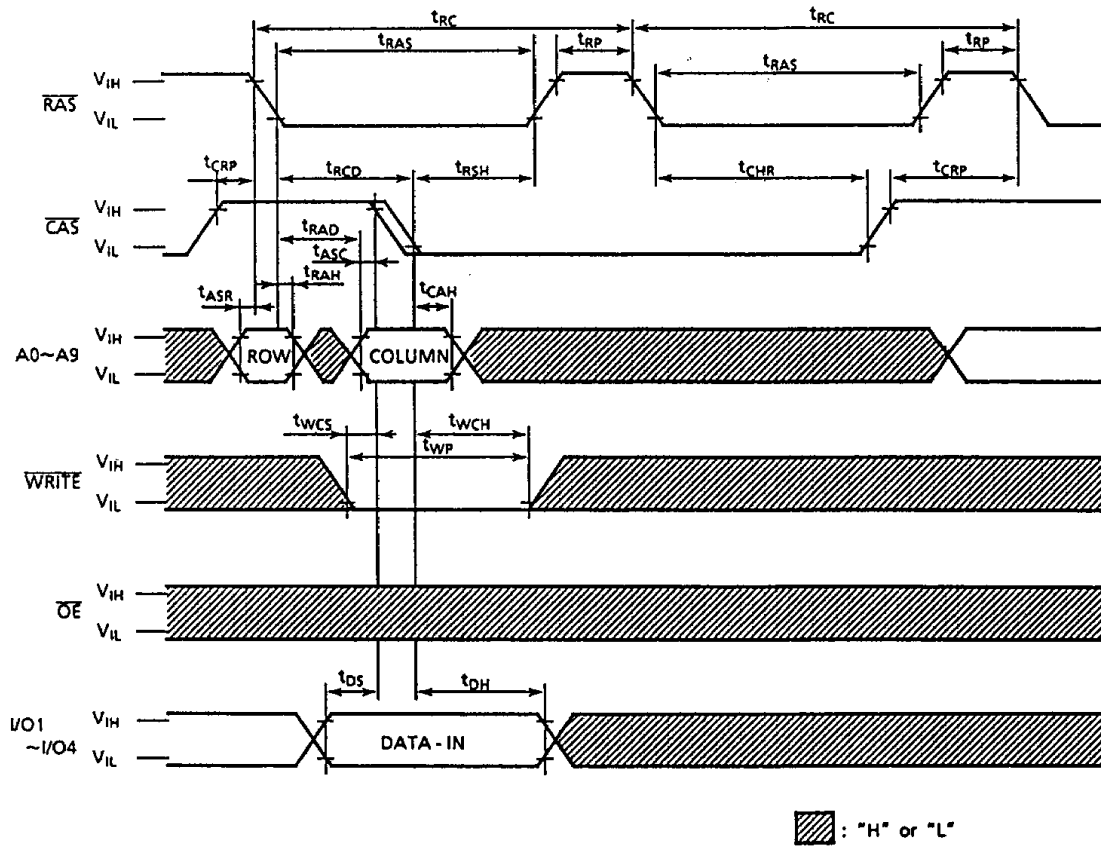

TC514400AP/AJ/ASJ/AZ-70, TC514400AP/AJ/ASJ/AZ-80  
 TC514400AP/AJ/ASJ/AZ-10

CAS BEFORE RAS REFRESH COUNTER TEST CYCLE

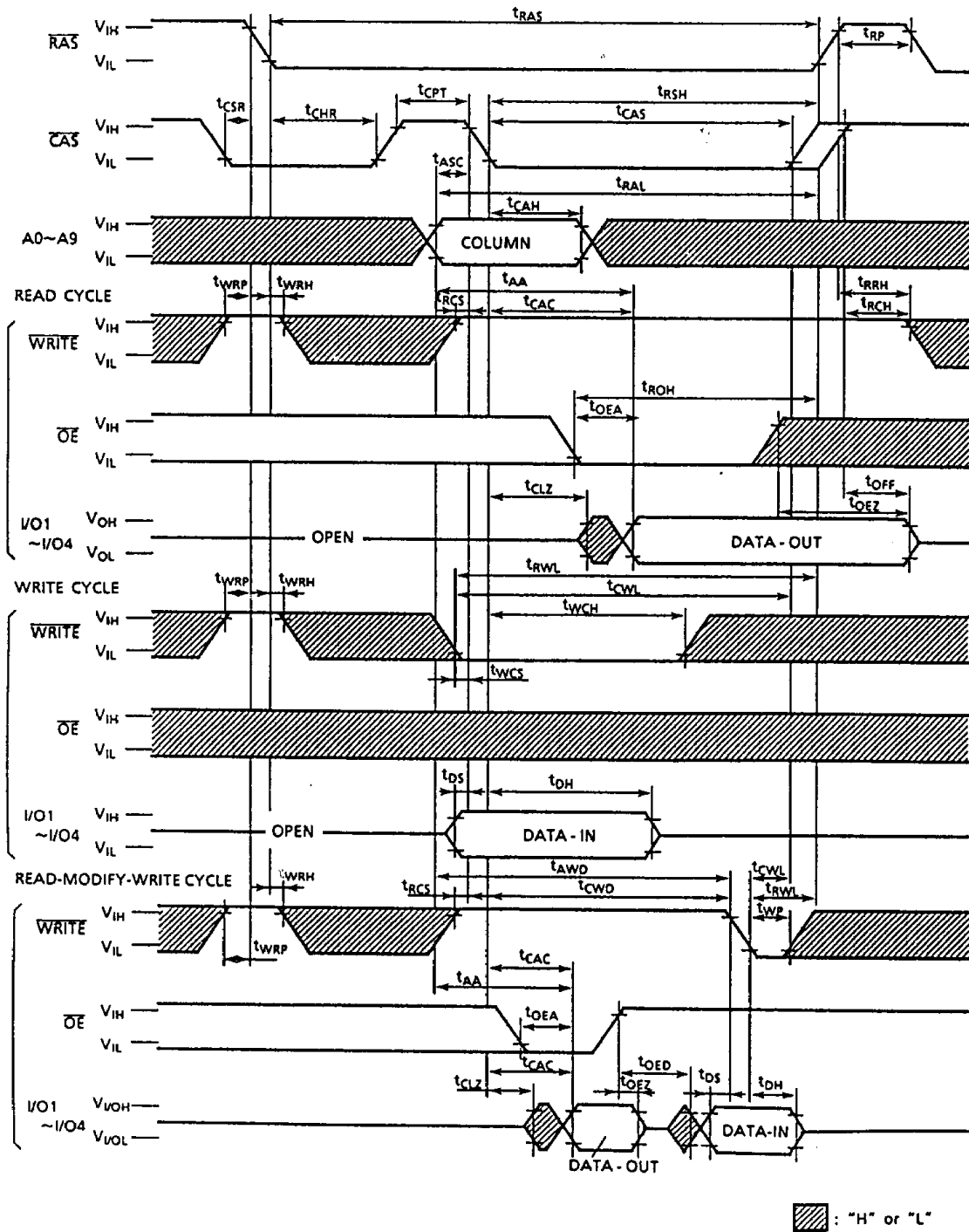

# TC514400AP/AJ/ASJ/AZ-70, TC514400AP/AJ/ASJ/AZ-80 TC514400AP/AJ/ASJ/AZ-10

## WRITE, CAS BEFORE RAS REFRESH CYCLE

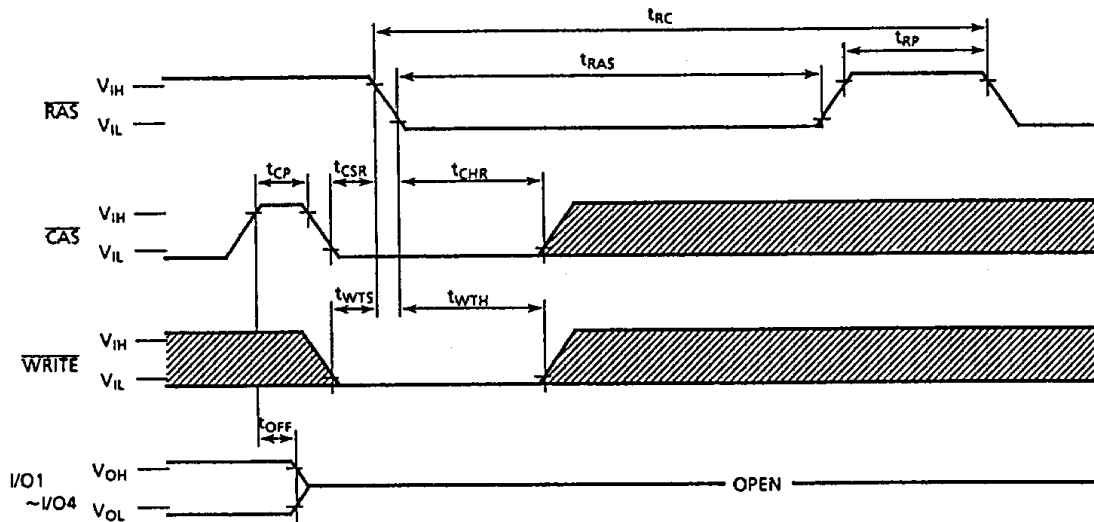

Note:  $\overline{OE}$ , A0~A9 = "H" or "L"

: "H" or "L"

# TC514400AP/AJ/ASJ/AZ-70, TC514400AP/AJ/ASJ/AZ-80 TC514400AP/AJ/ASJ/AZ-10

---

## TEST MODE

The TC514400AP/AJ/ASJ/AZ is the RAM organized 1,048,576 words by 4 bits, it is internally organized 524,288 words by 8 bits. In "Test Mode", data are written into 8 sectors in parallel and retrieved the same way. A0c is not used. If, upon reading, two bits on one I/O pin are equal (all "1"s or "0"s), the I/O pin indicates a "1".

If they were not equal, the I/O pin would indicate a "0". Fig.1 shows the block diagram of TC514400AP/AJ/ASJ/AZ. In "Test Mode", the 1M×4 DRAM can be tested as if it were a 512K×4 DRAM.

" $\overline{\text{WRITE}}$ ,  $\overline{\text{CAS}}$  Before  $\overline{\text{RAS}}$  Refresh Cycle" puts the device into "Test Mode". And " $\overline{\text{CAS}}$  Before  $\overline{\text{RAS}}$  Refresh Cycle" or " $\overline{\text{RAS}}$  Only Refresh Cycle" puts it back into "Normal Mode". In the Test Mode, " $\overline{\text{WRITE}}$ ,  $\overline{\text{CAS}}$  Before  $\overline{\text{RAS}}$  Refresh Cycle" Performs the refresh operation with the internal refresh address counter. The "Test Mode" function reduces test times (1/2 in case of N test pattern).

# TC514400AP/AJ/ASJ/AZ-70, TC514400AP/AJ/ASJ/AZ-80 TC514400AP/AJ/ASJ/AZ-10

## BLOCK DIAGRAM IN THE TEST MODE

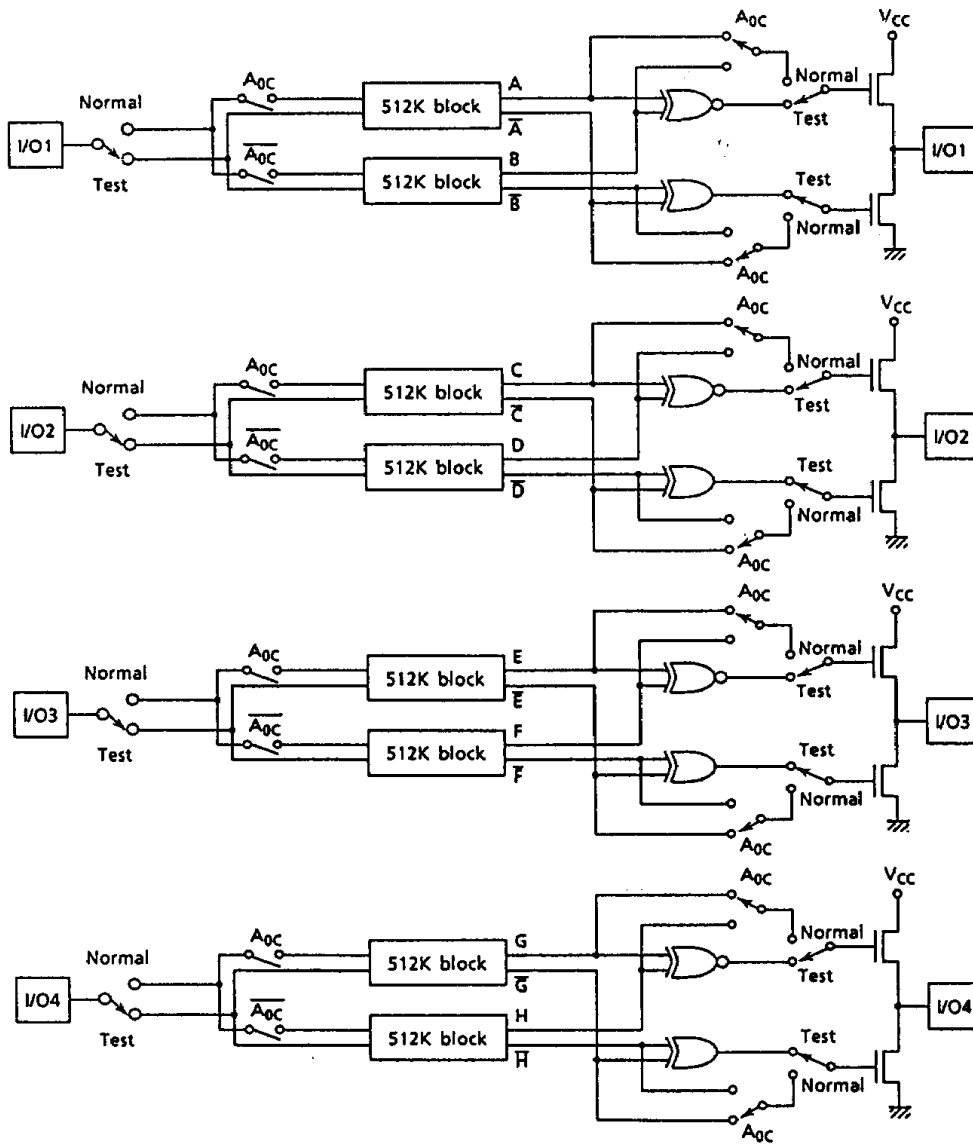

Fig. 1