

High Intensity Red Low Current Seven Segment Display

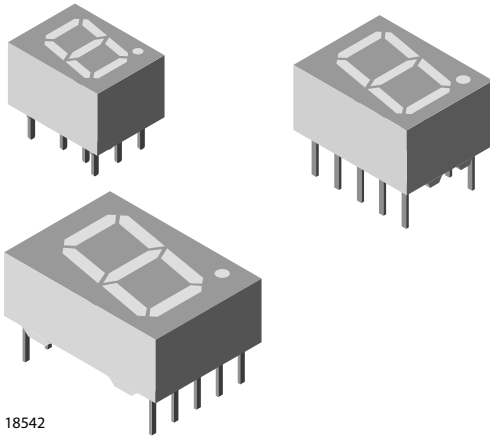

DESCRIPTION

This series defines a new standard for Low Current Displays. It is a single digit 7-segment LED display utilizing AllnGaP technology in color red.

The supreme light intensity allows applications under direct sunlight or "black front" designs by using tinted filter glass in front of the display.

Typical 1500 μcd at 1.0 mA is best in class performance for applications with very limited power supply. The maximum forward current of 10 mA is allowed for an ambient temperature range of - 40 to + 85 °C without current derating.

Crosstalk between segments is possible at drive currents above 5 mA per segment. Therefore it is recommend to apply more than 5 mA only under direct sunlight or with tinted filter glass.

FEATURES

- 1500 μcd typical at 1.0 mA
- Very low power consumption
- Wide viewing angle
- Grey package surface
- Light intensity categorized at $I_F = 1.0 \text{ mA}$
- Lead (Pb)-free component
- Component in accordance to RoHS 2002/95/EC and WEEE 2002/96/EC



APPLICATIONS

- Battery driven instruments
- Telecom devices
- Home appliances
- Instrumentation
- POS Terminals

PRODUCT GROUP AND PACKAGE DATA

- Product group: display
- Package: 7 mm/10 mm/13 mm
- Product series: low current

PARTS TABLE		
PART	COLOR, LUMINOUS INTENSITY	CIRCUITRY
TDSR0750	High intensity low current red	Common anode
TDSR0760	High intensity low current red	Common cathode
TDSR1050	High intensity low current red	Common anode
TDSR1060	High intensity low current red	Common cathode
TDSR1350	High intensity low current red	Common anode
TDSR1360	High intensity low current red	Common cathode

ABSOLUTE MAXIMUM RATINGS¹⁾ TDSR0750/0760, TDSR1050/1060, TDSR1350/1360				
PARAMETER	TEST CONDITION	SYMBOL	VALUE	UNIT
Reverse voltage per segment		V_R	5	V
DC Forward current per segment		I_F	10	mA
Peak forward current per segment	$t_p \leq 10 \mu\text{s}$, duty cycle 1/10	I_{FM}	50	mA
Power dissipation	$T_{amb} \leq 85 \text{ }^\circ\text{C}$	P_V	185	mW
Junction temperature		T_j	105	$^\circ\text{C}$
Operating temperature range		T_{amb}	- 40 to + 85	$^\circ\text{C}$
Storage temperature range		T_{stg}	- 40 to + 85	$^\circ\text{C}$
Soldering temperature	$t \leq 3 \text{ sec}$, 2 mm below seating plane	T_{sd}	260	$^\circ\text{C}$
Thermal resistance LED junction/ambient		R_{thJA}	100	K/W

Note:

¹⁾ $T_{amb} = 25 \text{ }^\circ\text{C}$, unless otherwise specified

OPTICAL AND ELECTRICAL CHARACTERISTICS¹⁾ RED						
PARAMETER	TEST CONDITION	SYMBOL	MIN	TYP.	MAX	UNIT
TDSR0750, TDSR0760						
Luminous intensity per segment (digit average)	$I_F = 1 \text{ mA}$	I_V	180		2200	μcd
Dominant wavelength	$I_F = 1 \text{ mA}$	λ_d		640		nm
Peak wavelength	$I_F = 1 \text{ mA}$	λ_p		650		nm
Forward voltage per segment or DP	$I_F = 1 \text{ mA}$	V_F		1.8	2.4	V
Reverse voltage per segment or DP	$V_R = 6 \text{ V}$	I_R		10		μA
TDSR1050, TDSR1060						
Luminous intensity per segment (digit average)	$I_F = 1 \text{ mA}$	I_V	280		3600	μcd
Dominant wavelength	$I_F = 1 \text{ mA}$	λ_d		640		nm
Peak wavelength	$I_F = 1 \text{ mA}$	λ_p		650		nm
Forward voltage per segment or DP	$I_F = 1 \text{ mA}$	V_F		1.8	2.4	V
Reverse voltage per segment or DP	$V_R = 6 \text{ V}$	I_R		10		μA
TDSR1350, TDSR1360						
Luminous intensity per segment (digit average)	$I_F = 1 \text{ mA}$	I_V	280		3600	μcd
Dominant wavelength	$I_F = 1 \text{ mA}$	λ_d		640		nm
Peak wavelength	$I_F = 1 \text{ mA}$	λ_p		650		nm
Forward voltage per segment or DP	$I_F = 1 \text{ mA}$	V_F		1.8	2.4	V
Reverse voltage per segment or DP	$V_R = 6 \text{ V}$	I_R		10		μA

Note:

¹⁾ $T_{amb} = 25 \text{ }^\circ\text{C}$, unless otherwise specified

TYPICAL CHARACTERISTICS

$T_{amb} = 25\text{ }^{\circ}\text{C}$, unless otherwise specified

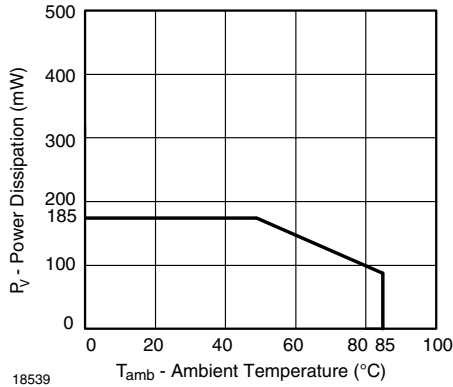

Figure 1. Power Dissipation vs. Ambient Temperature

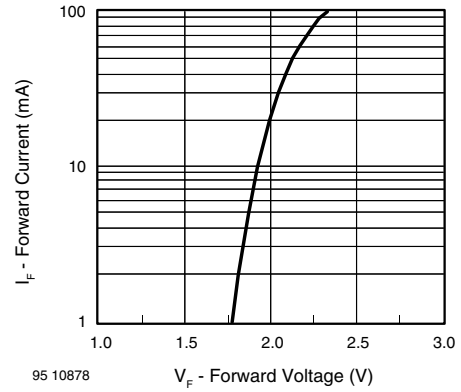

Figure 4. Forward Current vs. Forward Voltage

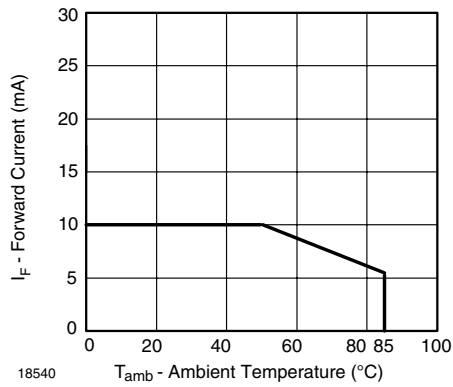

Figure 2. Forward Current vs. Ambient Temperature

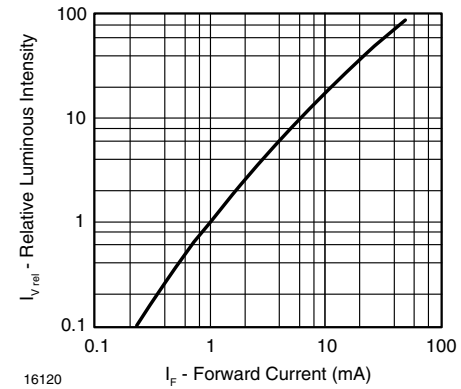

Figure 5. Relative Luminous Intensity vs. Forward Current

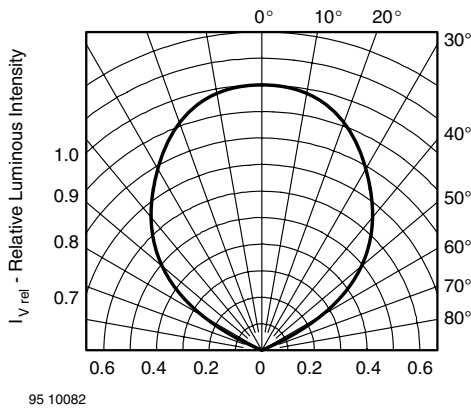

Figure 3. Rel. Luminous Intensity vs. Angular Displacement

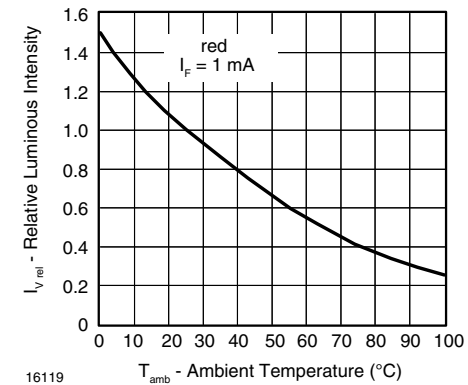

Figure 6. Rel. Luminous Intensity vs. Ambient Temperature

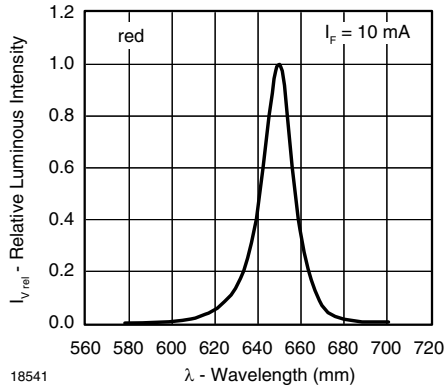

Figure 7. Rel. Luminous Intensity vs. Ambient Temperature

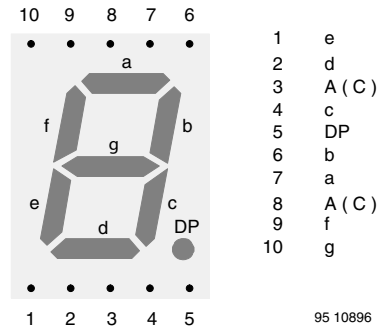

Figure 10. TDSR13..

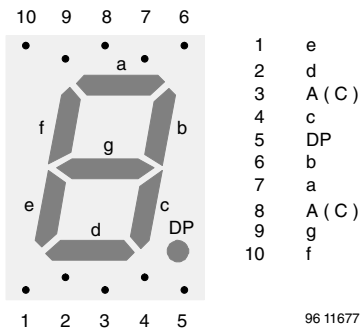

Figure 8. TDSR07..

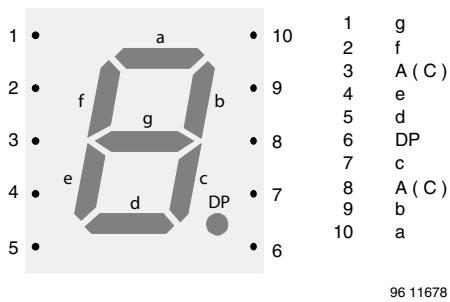
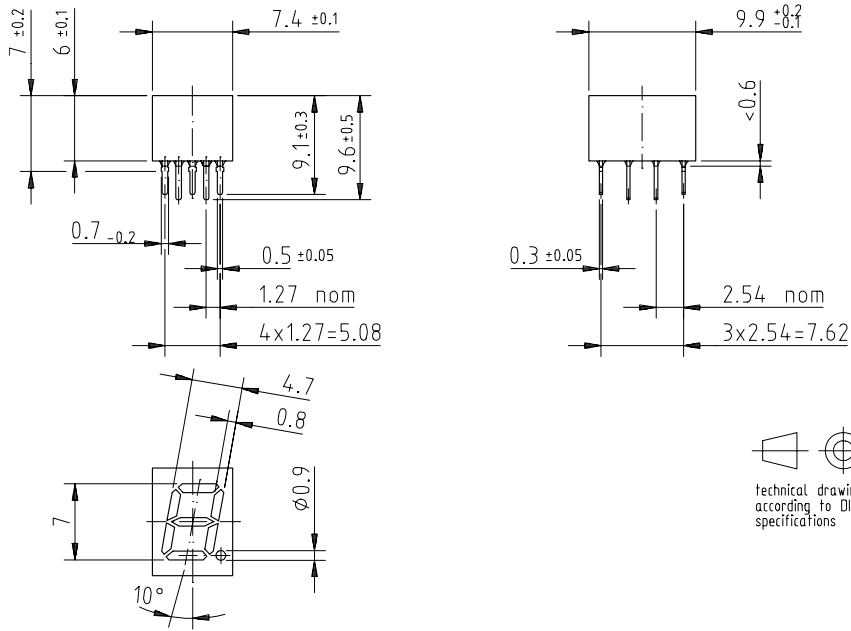

Figure 9. TDSR10..

PACKAGE DIMENSIONS FOR TDSR07.. in millimeters



95 11342

PACKAGE DIMENSIONS FOR TDSR10.. in millimeters

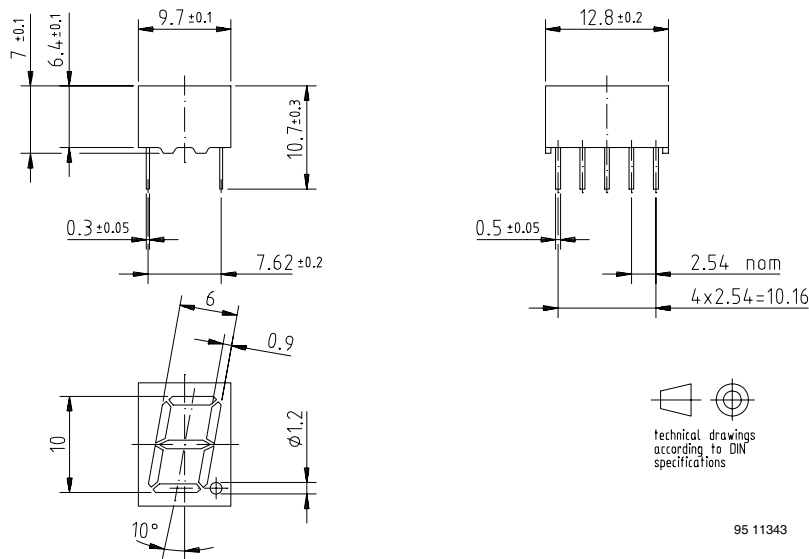

95 11343

PACKAGE DIMENSIONS FOR TDSR13.. in millimeters

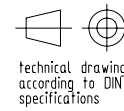
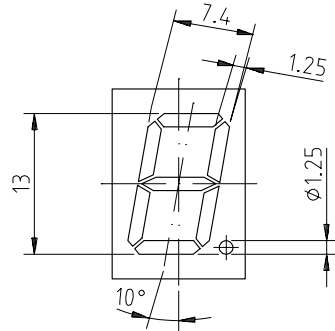
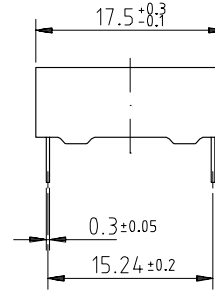
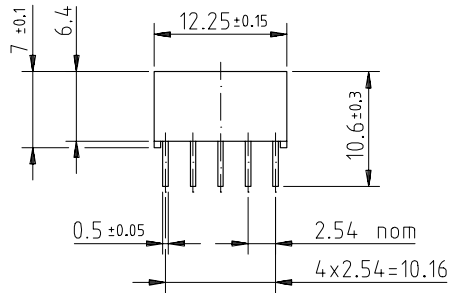

95 11344



OZONE DEPLETING SUBSTANCES POLICY STATEMENT

It is the policy of Vishay Semiconductor GmbH to

1. Meet all present and future national and international statutory requirements.
2. Regularly and continuously improve the performance of our products, processes, distribution and operating systems with respect to their impact on the health and safety of our employees and the public, as well as their impact on the environment.

It is particular concern to control or eliminate releases of those substances into the atmosphere which are known as ozone depleting substances (ODSs).

The Montreal Protocol (1987) and its London Amendments (1990) intend to severely restrict the use of ODSs and forbid their use within the next ten years. Various national and international initiatives are pressing for an earlier ban on these substances.

Vishay Semiconductor GmbH has been able to use its policy of continuous improvements to eliminate the use of ODSs listed in the following documents.

1. Annex A, B and list of transitional substances of the Montreal Protocol and the London Amendments respectively
2. Class I and II ozone depleting substances in the Clean Air Act Amendments of 1990 by the Environmental Protection Agency (EPA) in the USA
3. Council Decision 88/540/EEC and 91/690/EEC Annex A, B and C (transitional substances) respectively.

Vishay Semiconductor GmbH can certify that our semiconductors are not manufactured with ozone depleting substances and do not contain such substances.

We reserve the right to make changes to improve technical design
and may do so without further notice.

Parameters can vary in different applications. All operating parameters must be validated for each customer application by the customer. Should the buyer use Vishay Semiconductors products for any unintended or unauthorized application, the buyer shall indemnify Vishay Semiconductors against all claims, costs, damages, and expenses, arising out of, directly or indirectly, any claim of personal damage, injury or death associated with such unintended or unauthorized use.

Vishay Semiconductor GmbH, P.O.B. 3535, D-74025 Heilbronn, Germany



Disclaimer

All product specifications and data are subject to change without notice.

Vishay Intertechnology, Inc., its affiliates, agents, and employees, and all persons acting on its or their behalf (collectively, "Vishay"), disclaim any and all liability for any errors, inaccuracies or incompleteness contained herein or in any other disclosure relating to any product.

Vishay disclaims any and all liability arising out of the use or application of any product described herein or of any information provided herein to the maximum extent permitted by law. The product specifications do not expand or otherwise modify Vishay's terms and conditions of purchase, including but not limited to the warranty expressed therein, which apply to these products.

No license, express or implied, by estoppel or otherwise, to any intellectual property rights is granted by this document or by any conduct of Vishay.

The products shown herein are not designed for use in medical, life-saving, or life-sustaining applications unless otherwise expressly indicated. Customers using or selling Vishay products not expressly indicated for use in such applications do so entirely at their own risk and agree to fully indemnify Vishay for any damages arising or resulting from such use or sale. Please contact authorized Vishay personnel to obtain written terms and conditions regarding products designed for such applications.

Product names and markings noted herein may be trademarks of their respective owners.