

AXICOM

Telecom-, Signal and RF Relays

Cradle Relay Accessories and Mounting

108-98016 • Nov. 07 • Rev. C • ECOC: JM10

 **Tyco Electronics**

Our commitment. Your advantage.

Cradle Relay Accessories and Mounting

Disclaimer

While Tyco Electronics has made every reasonable effort to ensure the accuracy of the information in this datasheet, Tyco Electronics does not guarantee that it is error-free, nor does Tyco Electronics make any other representation, warranty or guarantee that the information is accurate, correct, reliable or current. Tyco Electronics reserves the right to make any adjustments to the information contained herein at any time without notice. Tyco Electronics expressly disclaims all implied warranties (and all express warranties, except as otherwise stated in this datasheet) regarding the information contained herein, including but not limited to any implied warranties or merchantability or fitness for a particular purpose. It is recommended that you test any new or replacement product before incorporating into a system.

The dimensions in this datasheet are for reference purpose only and are subject to change without notice. Specifications are subject to change without notice.

Index

Dimensions	5
General Data / Ordering Information	6
Dimensions	7

Cradle Relay Accessories and Mounting

Sockets with hand solder terminals

ROHS compliant (Directive 2002/95/EC)
as per product date code 0501.

Size I

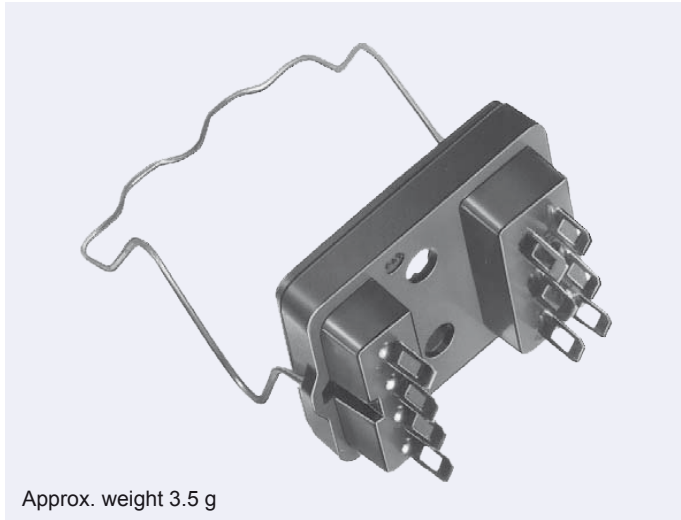

Size II

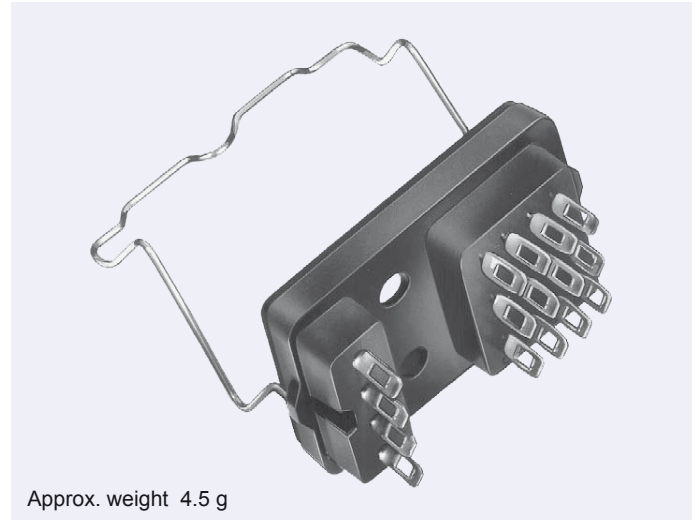

Size III

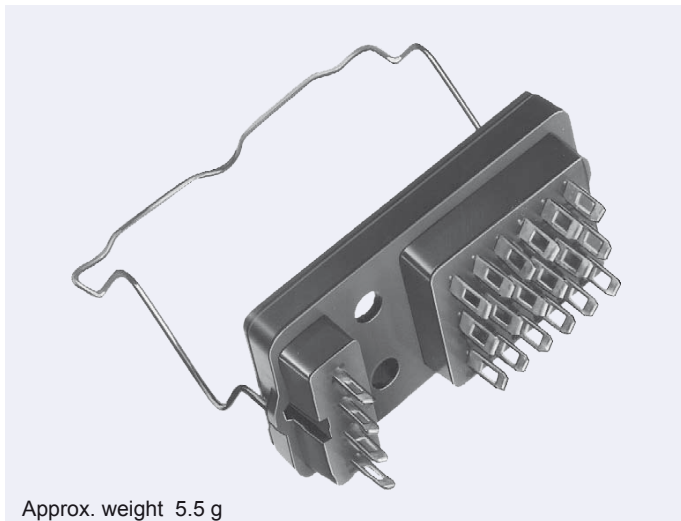

Cradle Relay Accessories and Mounting

Sockets with PCB terminals

ROHS compliant (Directive 2002/95/EC)
as per product date code 0501.

Size I

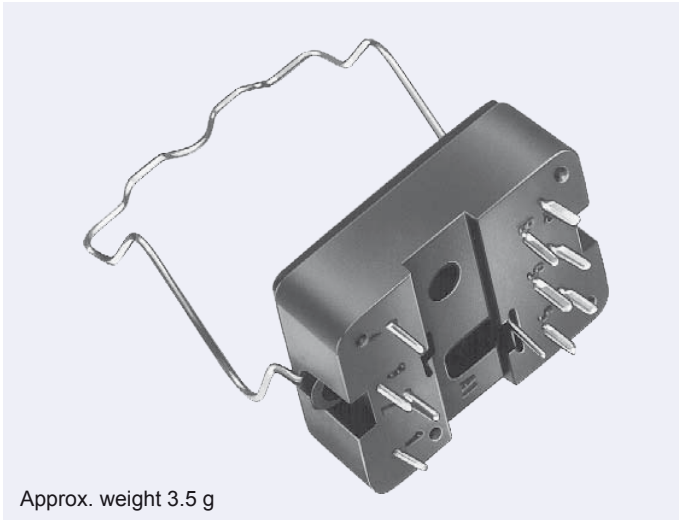

Size II

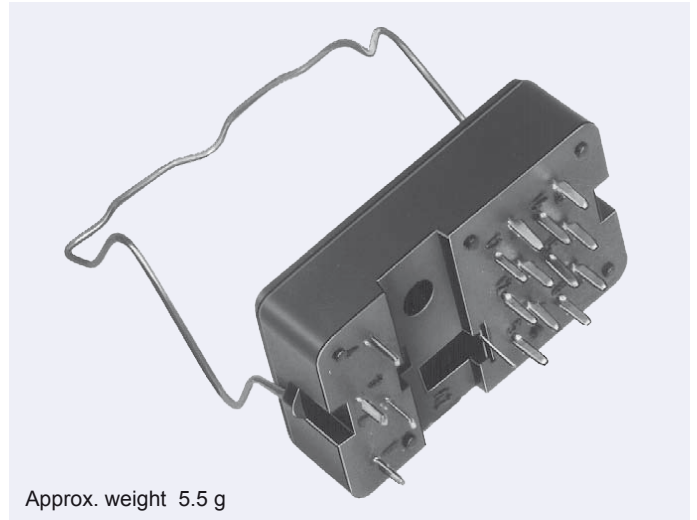

Size III

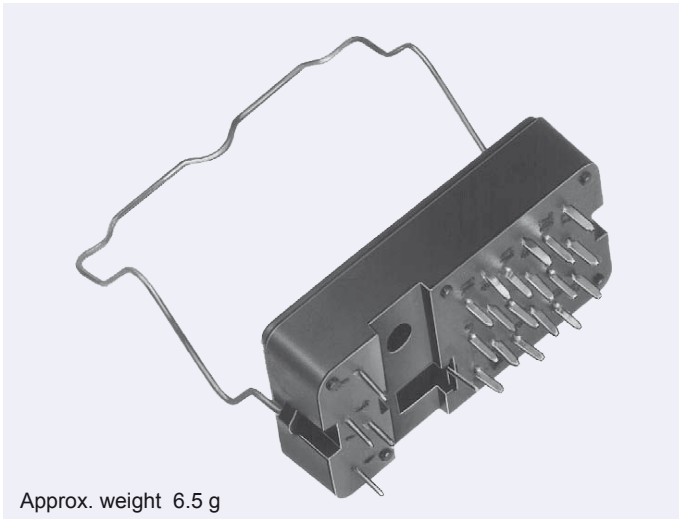

Cradle Relay Accessories and Mounting

Dimensions

Dimensions in mm

Sockets with hand solder terminals

with hold-down spring for cradle relays N, S and P

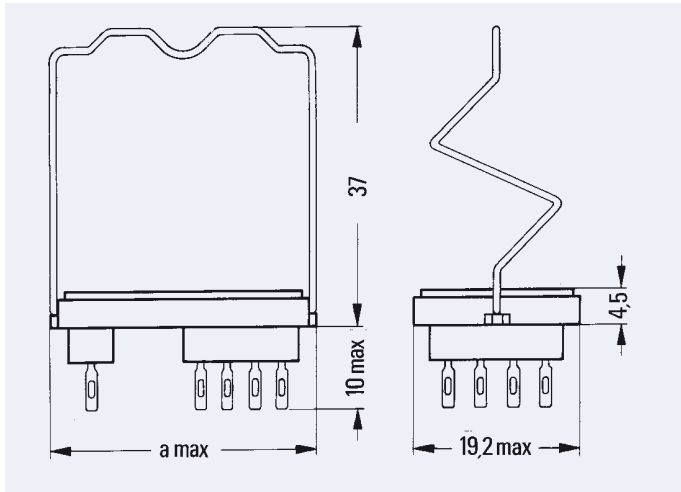

with hold-down spring for cradle relay W

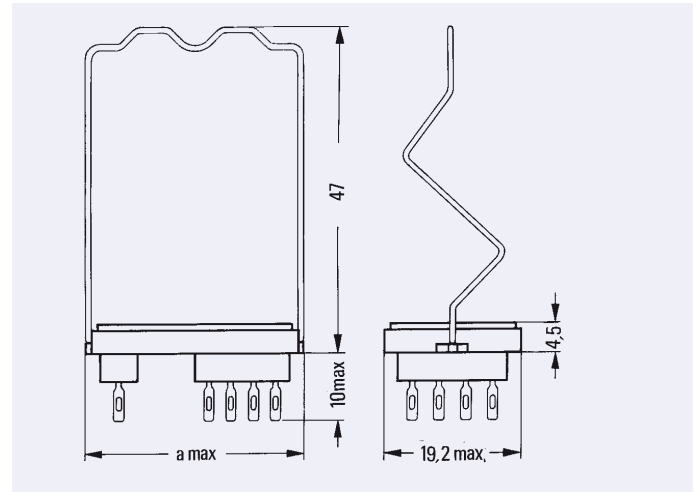

Sockets with PCB terminals

with hold-down spring for cradle relays N, S and P

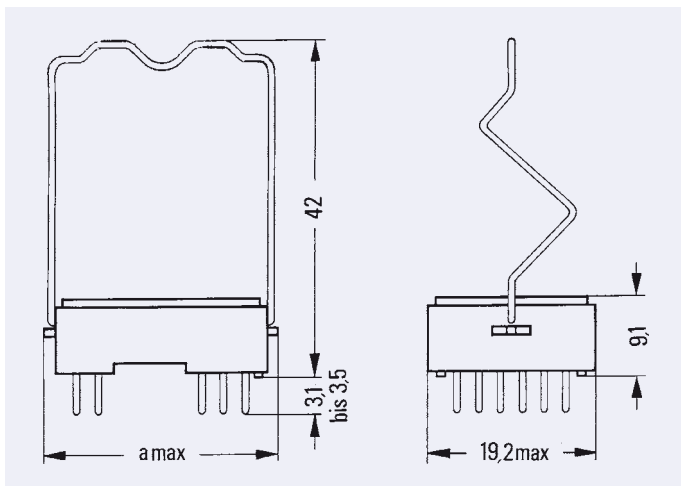

with hold-down spring for cradle relay W

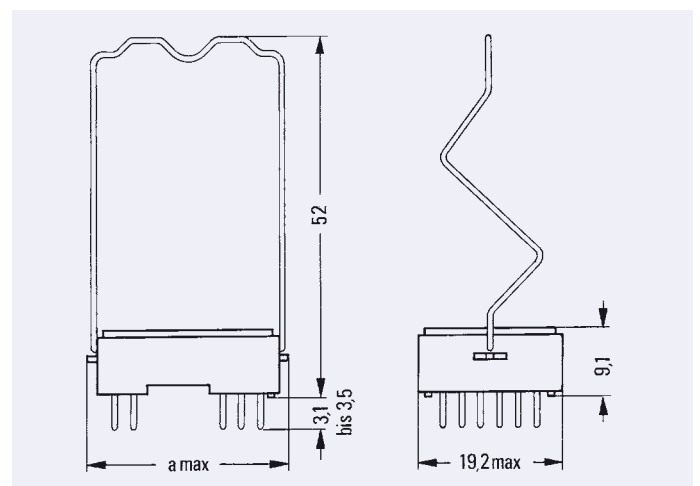

Socket	Size I	Size II	Size III
Dimension a	26.6	32.5	38

Cradle Relay Accessories and Mounting

Ordering Code

Version	Size	Ordering Code	Tyco Part Number
Sockets			
for printed circuit mounting, terminals silver-plated with earth terminal	I	V23154-Z1001	1393824-1
	II	V23154-Z1002	9-1393809-1
	III	V23154-Z1028	1-1393824-0
for solder terminals, hand solder terminals, silver-plated	I	V23154-Z1005	1393824-4
	II	V23154-Z1006	1393824-5
	III	V23154-Z1015	1393824-8
Hold-down springs			
for cradle relays N, S and P	I	V23154-Z1021	1393827-1
	II	V23154-Z1022	1393827-2
	III	V23154-Z1034	1393760-2
for cradle relay W	I	V23154-Z1023	1393827-3
	II	V23154-Z1024	1393760-1

Gold plated terminals on request

General Data

Terminal material	CuSn8 FB 390 plated with min. 3 µm silver or min. 1 µm gold
Socket material with solder terminals	Phenolformaldehyde - type 31 (DIN 7708, part 2)
Socket material with PCB terminals	Makrolon (polycarbonate)
Maximum continuous current at 70 °C	5 A

Cradle Relay Accessories and Mounting

Dimensions

Dimensions in mm

Minimum spacing between sockets

with hold-down spring for cradle relays N, S and P

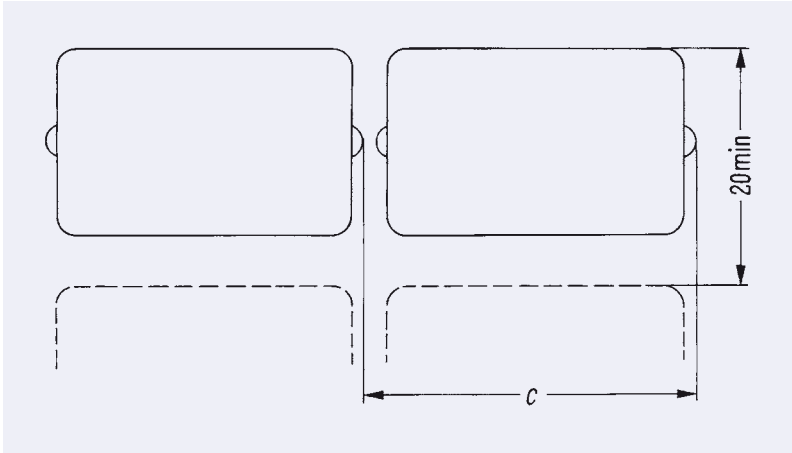

Socket	Dimension c
Size I	27
Size II	33
Size III	39

for cradle relay P

Relays oriented in the same direction

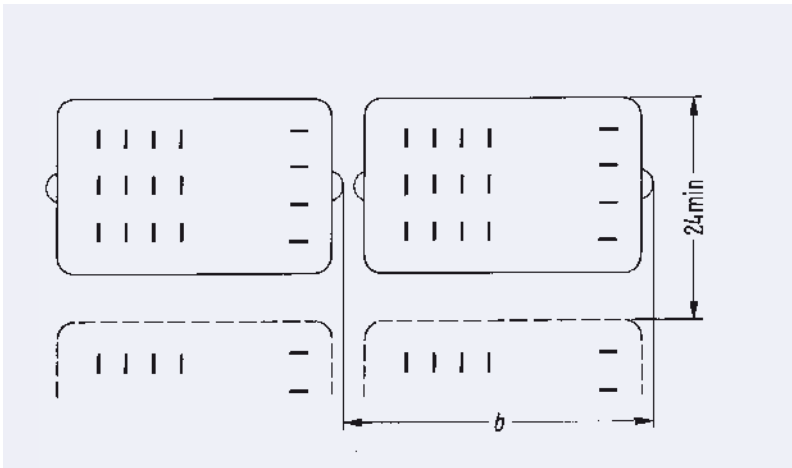

Socket	Dimension b	Dimension c
Size I	27	42
Size II	33	48
Size III	39	54

Relays oriented inversely to each other

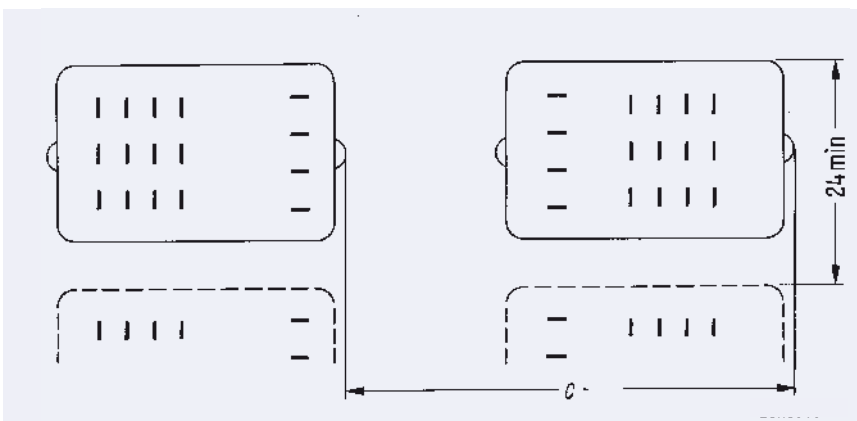

When mounting cradle relay P consideration should be given to magnetic fields. Strong DC magnetic fields, possibly caused by adjacent relays, and large iron masses are the most common causes of interference. Experience has shown that under normal operating conditions the minimum spacings specified for cradle relay P are sufficient to prevent cross interference.

Cradle Relay Accessories and Mounting

Dimensions

Dimensions in mm

Mounting hole layout for cradle relays and sockets with hand solder terminals

with hold-down spring for cradle relays N, S and P

Size I	Size II	Size III
--------	---------	----------

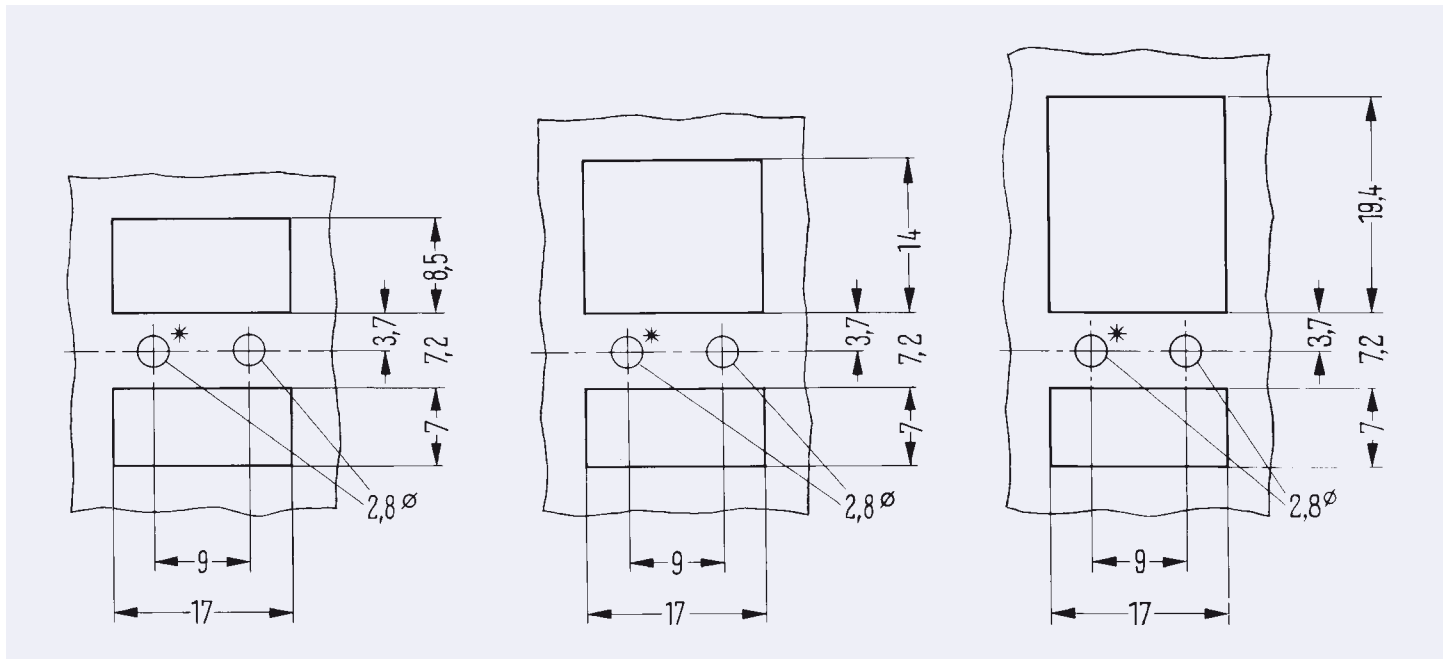

*) This hole is omitted when the mounting hole layout is intended for the socket.

Fixing of the socket

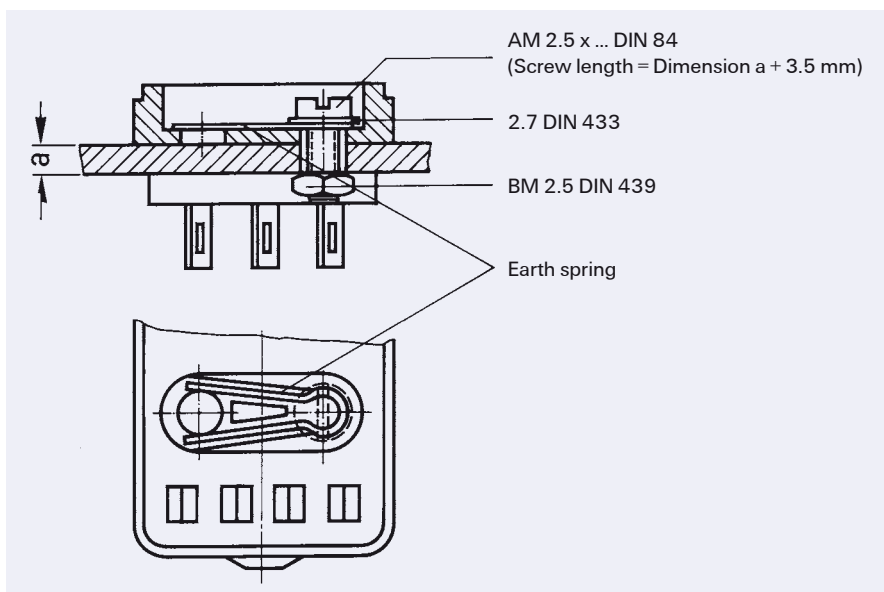

Direct mounting of relays without socket requires a fixing nut M2.5 DIN 934-m6AU.
Ordering code: D00934-A0025-S001

Cradle Relay Accessories and Mounting

Dimensions

Dimensions in mm

Mounting hole layout for sockets with PCB terminals

Basic grid 2.5 mm according to EN 60097

Size I Size II Size III

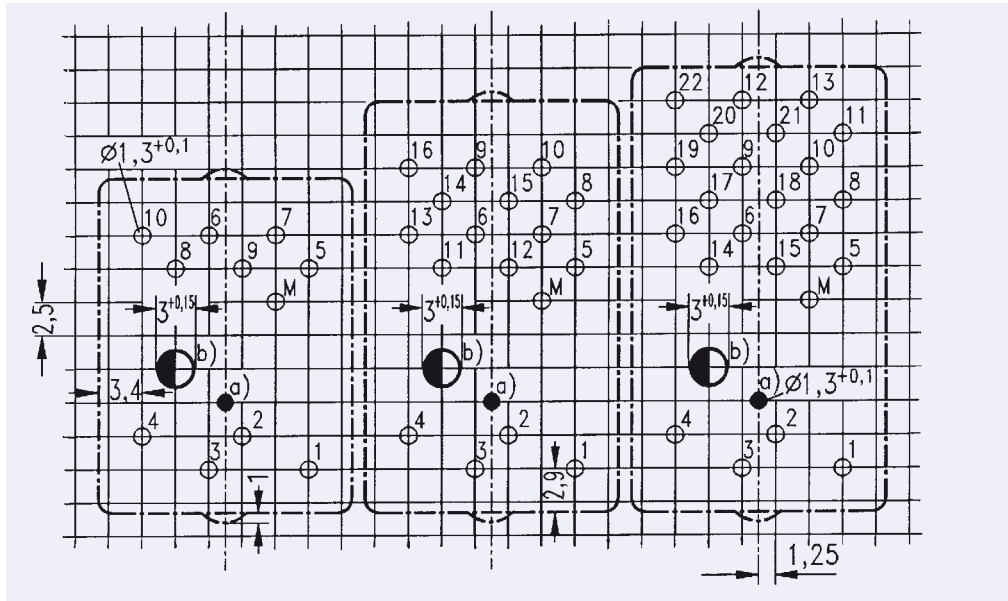

View onto the terminals

M = Earth terminal

- a) Hole for mechanical armature actuation, if required
- b) Hole for the socket mounting with screw M1.6

Fixing of the socket

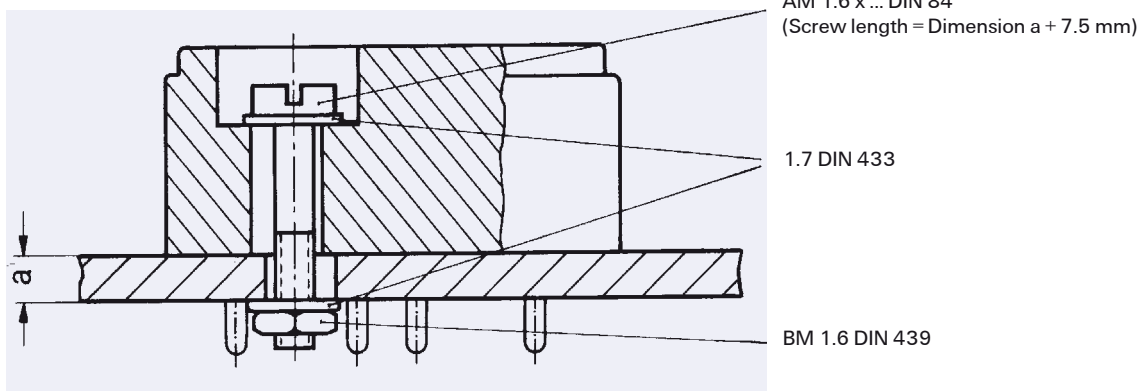

Cradle Relay Accessories and Mounting

IM Relays

4th generation slim line – low profile polarized 2 c/o telecom signal relay with bifurcated contacts, available as non latching or latching relay with 1 coil. Nominal voltage range from 1.5 ... 24 V, coil power consumption of 50 ... 200 mW, latching relays with 1 coil 100 mW. The IM relay is available as through hole and surface mount type (J-Legs and Gull Wings) and capable to switch loads up to 60 W/62,5 VA. It is currently the only 2 A rated 4G relay on the market. Dielectric strength fulfills the Telcordia requirements according GR 1089 (2,5 kV – 2 / 10 μ s) and FCC part 68 (1,5 kV – 10 / 160 μ s). The IM relay is tested according CECC/IECQ and certified in accordance with IEC/EN 60950 and UL 60950.

Dimensions approx. 10 x 6 mm board space and 5.65 mm height.

P2 Relays

3rd generation polarized 2 c/o telecom relay with bifurcated contacts, available as non latching or latching relay with 1 or 2 coils. Nominal voltage range from 3 ... 24 V, coil power consumption 140 mW, latching relays with 1 coil 70 mW. The P2 Relay is available as through hole or surface mount type and capable to switch currents up to 5 A. Dielectric strength fulfills the Telcordia requirements according GR 1089 (2,5 kV – 2 / 10 μ s) and FCC part 68 (1,5 kV – 10 / 160 μ s). The P2 relay is tested according CECC/IECQ and certified in accordance with IEC/EN 60950 and UL 60950. Dimensions approx. 15 x 7,5 mm board space and 10 mm height.

FX2 Relays

3rd generation polarized 2 c/o telecom relay with bifurcated contacts, available as non latching or latching relay with 1 coil. Nominal voltage range from 3 ... 48 V, coil power consumption of 80 ... 260 mW for the high sensitive version, 140... 300 mW for the standard version, latching relays with 1 coil 100 mW. The FX2 relay is available as through hole type and capable to switch loads up to 60 W/62,5 VA. Dielectric strength fulfills the Telcordia requirements according GR 1089 (2,5 kV – 2 / 10 μ s) and FCC part 68 (1,5 kV – 10 / 160 μ s). The FX2 relay is tested according CECC/IECQ and certified in accordance with IEC/EN 60950 and UL 60950. Dimensions approx. 15 x 7,5 mm board space and 10,7 mm height.

FT2 / FU2 Relays

3rd generation non polarized, non latching 2 c/o telecom relay with bifurcated contacts. Nominal voltage range from 3 ... 48 V, coil power consumption 200 ... 300 mW. Most sensitive 48 V relay. Available as through hole and surface mount type. Dielectric strength fulfills the Telcordia requirements according GR 1089 (2,5 kV – 2 / 10 μ s) and FCC part 68 (1,5 kV – 10 / 160 μ s). The FT2/FU2 relay is tested according CECC/IECQ and certified in accordance with IEC/EN 60950 and UL 60950. Dimensions approx. 15 x 7,5 mm board space and 10 mm height.

FP2 Relays

3rd generation polarized 2 c/o telecom relay with bifurcated contacts, available as non latching or latching relay with 1 or 2 coils. Nominal voltage range from 3 ... 48 V, coil power consumption of 80 ... 260 mW for the high sensitive version, 140... 300 mW for the standard version, latching relays with 1 coil 100 mW. The FP2 Relay is available as through hole type and capable to switch loads up to 60 W/62,5 VA. Dielectric strength fulfills FCC part 68 (1,5 kV – 10 / 160 μ s). The FP2 is tested according CECC/IECQ approved.

Dimensions approx. 14 x 9 mm board space and 5 mm height.

MT2

2nd generation non polarized, non latching 2 c/o telecom and signal relay with bifurcated contacts. Nominal voltage range from 3 ... 48 V, coil power consumption 150/200/300/400 and 550 mW. Dielectric strength fulfills the requirements according FCC part 68 (1,5 kV – 10 / 160 μ s).

Dimensions approx. 20 x 10 mm board space and 11 mm height.

D2n Relays

2nd generation non polarized 2 c/o relay for telecom and various other applications. Nominal voltage range from 3 ... 48 V, coil power consumption from 150 ... 500 mW. The D2n relay is capable to switch currents up to 3 A. Dielectric strength fulfills the requirements according FCC part 68 (1,5 kV – 10 / 160 μ s). Dimensions approx. 20 x10 mm board space and 11 mm height.

P1 Relays

Extremely sensitive, polarized 1 c/o relay with bifurcated contacts for a wide range of applications, available as non latching or latching relay with 1 or 2 coils. Nominal voltage range from 3 ... 24 V, coil power consumption 65 mW, latching relays with 1 coil 30 mW. The P1 relay is available as through hole or surface mount type and capable to switch currents up to 1 A. Dielectric strength fulfills the requirements according FCC part 68 (1,5 kV – 10 / 160 μ s). Dimensions approx. 13 x 7,6 mm board space and 7 mm height for THT or 8 mm height for SMT version.

W11 Relays

Low cost, non polarized 1 c/o relay for various applications. Nominal voltage range from 3 ... 24 V, coil power consumption 450 mW, sensitive versions 200 mW. The W11 relay is capable to switch currents up to 3 A. Dielectric strength 1000 Vrms.

Dimensions approx. 15,6 x 10,6 mm board space and 11,5 mm height.

Reed Relays

High sensitive, non polarized relay for telecom and various other applications, available with 1 n/o, 2 n/o or 1c/o contacts. Nominal voltage range from 5 ... 24 V, coil power consumption 50...280 mW for 1 n/o and 125 ... 280 mW for 2 n/o or 1 c/o versions. Reedrelays are available in DIP or SIL housing and capable to switch currents up to 0,5 A. Integrated diode and/or electrostatic shield optional. Dielectric strength 1500 Vdc. Dimensions approx. 19,3 x 7 mm board space and 5 ... 7,5 mm height for DIP or 19,8 x 5 mm board space and 7,8 mm height for SIL version.

Cradle Relays

Extremely reliable and mature relay family of 1st generation for various signal switching applications. Available as non polarized, polarized / latching and relay with AC coil. The benefit is the possibility of combining various contact sets from 1 up to 6 poles, single and bifurcated contacts, different contact materials with a coil voltage range from 1,5 Vdc to 220 Vac. Cradle relays are available as dust protected and hermetically sealed versions, with plug in or solder terminals and are capable to switch currents up to 5 A. Forcibly guided (linked) contact sets optional. Dielectric strength 500 Vrms. Dimensions from approx. 19 x 24 to 19x35 mm board space and 30 mm height.

Other Relays

We offer a variety of different relay families for maintenance and replacement purposes. These relays are up to 60 years old now, such as Card Relay SN (V23030 series), Small General Purpose Relay (V23006 series), Small Polarized Relay (V23063 ... V23067 and V23163 ... V23167 series). Accessories like sockets, hold down springs, etc. optional.

High Frequency Relays

HF3 / HF3S / HF6 series RF relays offering excellent RF characteristics in a small package. All HF series relays are suitable for SMD soldering processes. Available as non latching or latching versions with 1 or 2 coils and a nominal coil voltage range from 3 ... 24 V, a coil power consumption of 140 mW or 70 mW (single coil latching types).

HF3: Low cost RF relay suitable up to 3 GHz. Impedance 50 and 75 Ohm. 50 W hot switching and 50 W RF power carry capability. Dimensions 14.6 x 7.3 x 10.3 mm.

HF3S: High performance, high power RF relay suitable up to 3 GHz, 50 W hot switching and 150 W RF power carry capability. Dimensions 15 x 7.6 x 10.6 mm.

HF6: High performance, high power RF relay suitable up to 6 GHz, 50 W hot switching and 50 W RF power carry capability. Dimensions 15 x 7.6 x 10.6 mm.