

saia



# Table of Contents

---

|   |                      |    |
|---|----------------------|----|
| <b>Johnson Electric Group</b>                     |                      | 2  |
| Group   |                      |    |
| Looking for a specialized switch solution         |                      | 4  |
| Table of typical applications & Saia switch types |                      | 8  |
| Terminology                                       |                      | 9  |
| Microswitches                                     |                      | 18 |
| Subminiature                                      | XC, X4, V4N, V4NC    |    |
| Miniature   | XG, X3, 390, 340, G3 |    |
| Table of preferred products                       |                      | 57 |

# Looking for a specialized switching solution?

---

## Look no further.

In addition to the wide range of standard products shown in this catalog, we will be happy to working with you to meet your switching needs. If your application requires more than a standard product solution, please consider us early in your design process. Our product development team will be happy to discuss your specification, whether you need a special switch design or a complete value-added assembly. We specialize in developing switches for high-volume applications.

The images shown give some examples of our capabilities.



## Table of typical applications & Saia switch types

In addition to the products shown in the Product Catalog pages, the Product Mapping table below shows a wide range of switch types for a selection of applications. Also, a switch may be customized to fulfill your specific requirements, please feel free to contact us.

| Application & Switch Series | XC | X4 | V4N | V4NC | XG | X3 | 390 | 340 | G3 |
|-----------------------------|----|----|-----|------|----|----|-----|-----|----|
| Cash machine                | ●  |    | ●   | ●    |    |    |     |     |    |
| Circuit Breaker             | ●  | ●  | ●   | ●    | ●  | ●  |     |     |    |
| Commercial Equipment        | ●  | ●  | ●   | ●    | ●  | ●  | ●   | ●   | ●  |
| Copier & Printer            | ●  |    | ●   | ●    | ●  |    |     |     |    |
| Distribution                | ●  | ●  | ●   | ●    | ●  | ●  | ●   | ●   | ●  |
| Doors & gates               | ●  |    | ●   | ●    | ●  | ●  | ●   | ●   |    |
| Floor cleaning machines     |    |    | ●   | ●    |    |    |     |     |    |
| Forklifts                   | ●  |    | ●   | ●    | ●  |    |     |     |    |
| Home Appliances             | ●  | ●  | ●   | ●    | ●  | ●  | ●   | ●   | ●  |
| HVAC                        | ●  | ●  | ●   | ●    | ●  | ●  | ●   | ●   | ●  |
| Industrial automation       | ●  |    | ●   | ●    | ●  |    |     |     |    |
| Industry general            | ●  | ●  | ●   | ●    | ●  | ●  | ●   | ●   | ●  |
| Medical                     | ●  |    | ●   | ●    | ●  |    |     |     |    |
| Postal                      | ●  |    | ●   | ●    |    |    |     |     |    |
| Power tools                 |    |    | ●   | ●    |    |    |     |     | ●  |
| Safety and Security         | ●  |    | ●   | ●    | ●  |    |     |     | ●  |
| Specialist vehicles         | ●  |    | ●   | ●    | ●  | ●  |     |     | ●  |
| Telecom                     | ●  |    | ●   | ●    | ●  |    |     |     |    |
| Vending / Gaming            | ●  | ●  | ●   | ●    | ●  | ●  |     |     | ●  |
| Waterheaters/Showers        | ●  |    | ●   | ●    | ●  |    | ●   | ●   |    |
| Page                        | 18 | 23 | 28  | 32   | 37 | 42 | 47  | 50  | 54 |

# Snap-action Microswitches

## Subminiature



| Type            | XC  | X4   | V4N   | V4NC  |
|-----------------|---|--|---|---|
| Characteristics | <ul style="list-style-type: none"> <li>wide range of forces and variants</li> <li>long mechanical and electrical life</li> <li>solder, PCB and faston terminals</li> <li>compliant to glow wire test IEC 60335-1, 4. ed.</li> </ul> | <ul style="list-style-type: none"> <li>thermoplastic housing</li> <li>long mechanical and electrical life</li> <li>solder, PCB and faston terminals</li> </ul> | <ul style="list-style-type: none"> <li>sealed (IP67)</li> <li>solder 2.8 mm faston and PCB terminals</li> <li>pre-wired option</li> </ul>           | <ul style="list-style-type: none"> <li>wide variety of levers</li> <li>peg mounting option</li> <li>pre-wired option</li> <li>sealed (IP6K7)</li> <li>solder and faston terminals</li> <li>PCB terminals</li> </ul> |
| Rating          | 250 VAC, 10 A max.  | 250 VAC, 12 A max.   | 250 VAC, 5 A  | 250 VAC, 5 A  |
| Dimensions (mm) | 19.9 × 9.5 × 6.4  | 19.9 × 9.7 × 6.4   | 20 × 10.3 × 6.4   | 20 × 10.3 × 6.4   |
| Actuator        | <ul style="list-style-type: none"> <li>plunger</li> <li>mushroom plunger</li> <li>plain levers</li> <li>simulated roller lever/cam follower</li> <li>roller levers</li> </ul>   | <ul style="list-style-type: none"> <li>plunger</li> <li>plain levers</li> <li>cam follower lever</li> <li>roller levers</li> </ul>                             | <ul style="list-style-type: none"> <li>plunger</li> <li>plain levers</li> <li>roller levers</li> <li>simulated roller lever/cam follower</li> </ul> | <ul style="list-style-type: none"> <li>plunger</li> <li>plain levers</li> <li>roller levers</li> <li>simulated roller lever/cam follower</li> </ul>   |
| Approvals       | ENEC, UL, cUL, CSA  | UL, cUL, CSA, ENEC, CQC  | UL, CSA, ENEC   | none  |
| Page            | 18  | 23   | 28  | 32  |

## Miniature



| Type            | XG   | X3  | 390   | 340  | G3   |
|-----------------|--|---|---|--|--|
| Characteristics | <ul style="list-style-type: none"> <li>wide range of forces and ratings</li> <li>long mechanical and electrical life</li> <li>solder, faston and PCB terminals</li> <li>compliant to glow wire test IEC 60335-1, 4. ed.</li> </ul> | <ul style="list-style-type: none"> <li>8 mm creepage and clearance distance to the actuator</li> <li>long mechanical and electrical life</li> <li>solder, faston and PCB terminals</li> </ul> | <ul style="list-style-type: none"> <li>wiping contacts, leaf spring mechanism</li> <li>rast 5 terminal option</li> </ul>      | <ul style="list-style-type: none"> <li>wiping contacts, leaf spring mechanism</li> <li>3 mm contact gap option</li> </ul>                                    | <ul style="list-style-type: none"> <li>low operating force, high current capacity</li> <li>&lt; 15 cN operating force option</li> <li>&gt; 3 mm contact gap, change-over mechanism option</li> </ul> |
| Rating          | 250 VAC, 26 A max.   | 250 VAC, 21 A max.  | 250 VAC, 25 A max.  | 250 VAC, 16 A max.   | up to 250 VAC, 18 A  |
| Dimensions (mm) | 27.8 × 15.9 × 10.3   | 27.8 × 15.9 × 10.3  | 28.8 × 15.9 × 10.1  | 28.8 × 15.9 × 10.1   | 28 × 15.9 × 10   |
| Actuator        | <ul style="list-style-type: none"> <li>plunger</li> <li>plain levers</li> <li>roller levers</li> <li>simulated roller levers</li> </ul>  | <ul style="list-style-type: none"> <li>plunger</li> <li>straight lever</li> <li>simulated roller levers</li> <li>roller levers</li> </ul>   | <ul style="list-style-type: none"> <li>plunger</li> <li>plain levers</li> <li>roller levers</li> <li>moulded lever</li> </ul> | <ul style="list-style-type: none"> <li>plunger</li> <li>roller lever</li> <li>plain levers</li> <li>simulated roller lever</li> <li>moulded lever</li> </ul> | <ul style="list-style-type: none"> <li>plunger</li> <li>ramp plunger</li> </ul>  |
| Approvals       | ENEC, UL, cUL, CSA   | UL, cUL, CSA, ENEC, CQC   | ENEC, UL, CSA   | ENEC   | ENEC, UL, CSA  |
| Page            | 37   | 42  | 47  | 50   | 54   |

# Thermoset plastic Microswitches

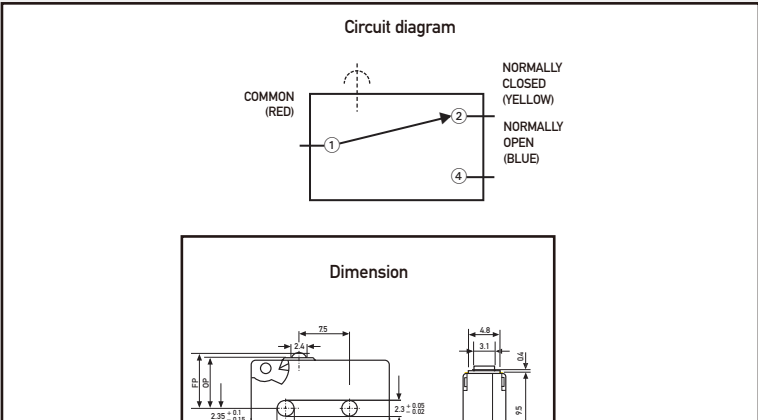
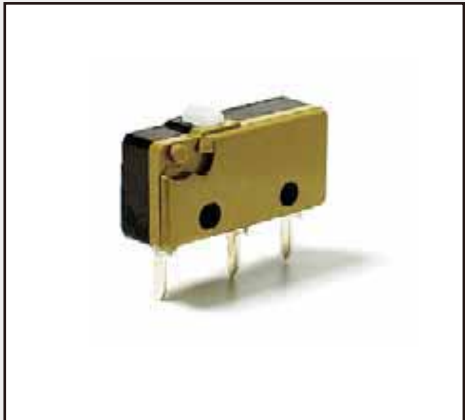

innovating motion

## XC

Characteristics

- wide range of forces and variants
- long mechanical and electrical life
- solder, PCB and faston terminals
- compliant to glow wire requirements as to IEC 60335-1, 4. ed.

Rating 250 VAC, 10 A max.

Dimensions (mm) 19.9 × 9.5 × 6.4

Actuator

- Plunger
- mushroom plunger
- plain levers
- simulated roller lever/cam follower
- roller levers

Approvals ENEC, UL, cUL, CSA



### Preferred Range

| Ordering Reference | Actuating Force<br>(N) (ozf) |       | Operating pos.<br>(mm) (in) |      | Terminal            | Circuit | Actuator         | Contacts | Electrical rating<br>ENEC | UL/CSA          |
|--------------------|------------------------------|-------|-----------------------------|------|---------------------|---------|------------------|----------|---------------------------|-----------------|
| XCG3Z1             | 1.7                          | 6.07  | 8.4                         | 0.33 | Solder              | CO      | Plunger          | Ag       | 6(2) A                    | 5 A             |
| XCG3-J1Z1          | 0.6                          | 2.14  | 10.2                        | 0.40 | Solder              | CO      | Plain lever      | Ag       | 6(2) A                    | 5 A             |
| XCG3-S1Z1          | 0.7                          | 2.49  | 15.6                        | 0.61 | Solder              | CO      | Roller lever     | Ag       | 6(2) A                    | 5 A             |
| XCG5Z1             | 1.7                          | 6.07  | 8.4                         | 0.33 | Faston 2.8 × 0.5 mm | CO      | Plunger          | Ag       | 6(2) A                    | 5 A             |
| XCG5-J1Z1          | 0.6                          | 2.14  | 10.2                        | 0.40 | Faston 2.8 × 0.5 mm | CO      | Plain lever      | Ag       | 6(2) A                    | 5 A             |
| XCG5-S1Z1          | 0.7                          | 2.49  | 15.6                        | 0.61 | Faston 2.8 × 0.5 mm | CO      | Roller lever     | Ag       | 6(2) A                    | 5 A             |
| XCG8-81Z1          | 1.7                          | 6.07  | 8.4                         | 0.33 | PCB                 | CO      | Plunger          | Au       | none                      | 0,1 A / 125 VAC |
| XCG8-81-J1Z1       | 0.6                          | 2.14  | 10.2                        | 0.40 | PCB                 | CO      | Plain lever      | Au       | none                      | 0,1 A / 125 VAC |
| XCG8-81-S1Z1       | 0.7                          | 2.49  | 15.6                        | 0.61 | PCB                 | CO      | Roller lever     | Au       | none                      | 0,1 A / 125 VAC |
| XCF3Z1             | 3                            | 10.70 | 8.4                         | 0.33 | Solder              | CO      | Plunger          | Ag       | 10(3) A                   | 10,1 A          |
| XCF3-J1Z1          | 1.05                         | 3.74  | 10.2                        | 0.40 | Solder              | CO      | Plain lever      | Ag       | 10(3) A                   | 10,1 A          |
| XCF3-S1Z1          | 1.1                          | 3.92  | 15.6                        | 0.61 | Solder              | CO      | Roller lever     | Ag       | 10(3) A                   | 10,1 A          |
| XCG3-U1Z1          | 1.7                          | 6.07  | 9.9                         | 0.39 | Solder              | CO      | Mushroom plunger | Ag       | 6(2) A                    | 5 A             |
| XCG4-U1Z1          | 1.7                          | 6.07  | 9.9                         | 0.39 | Faston 2.8 × 0.5 mm | CO      | Mushroom plunger | Ag       | 6(2) A                    | 5 A             |
| XCG8-U1Z1          | 1.7                          | 6.07  | 9.9                         | 0.39 | PCB                 | CO      | Mushroom plunger | Ag       | 6(2) A                    | 5 A             |

## Specifications

|                      |   |
|----------------------|---|
| Housing              | Melamine-Formaldehyd, Thermosetting   |
| Plunger              | POM for T85, PBT for T125, PPS for T150   |
| Mechanism            | Snap-action system with stainless steel tension spring  |
| Functions            | Change-over, NO, NC   |
| Contacts             | Fine silver (Ag) or 10 µm Gold (Au), microprofile   |
| Terminals            | Solder, faston and various PCB terminals (side of housing or side of lid, as well as 1/10" o lin pitch) |
| Temperature range °C | Between -40°C and +85°C (special version up to 140°C)   |
| Mechanical life      | up to 5-10 <sup>7</sup> cycles (sinusoidal actuation)   |
| Protection           | Enclosure IP40  |
| Mounting             | Side mounting through mounting holes  |
| Actuators            | Stainless steel, PA66-GF35  |
| Contact Carrier      | CuZn or CuSn  |

Circuit diagram

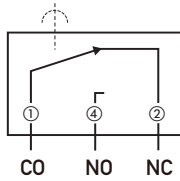

Actuating force/travel

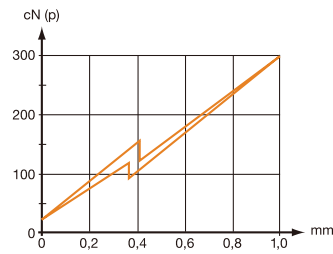

Contact force/travel

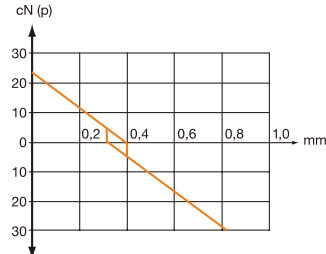

Dimensions

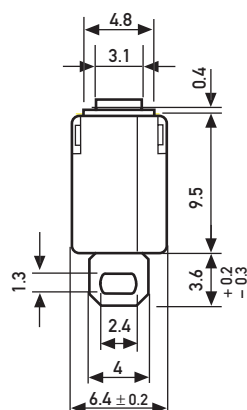
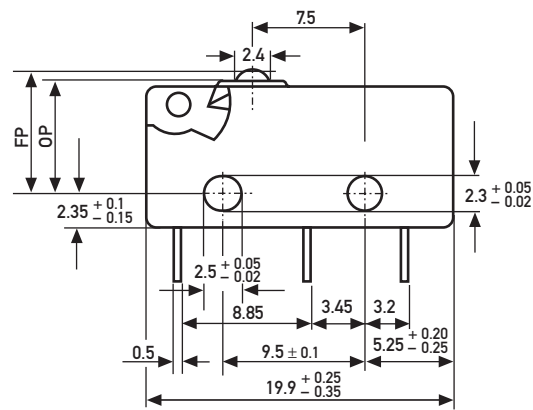

FP = Free Position  
OP = Operating Position

Maximum DC rating

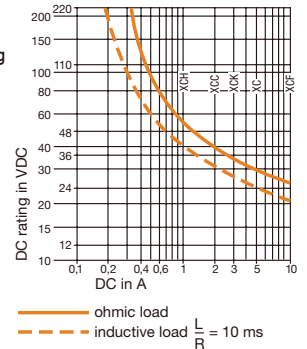

## Recommended maximum electrical ratings

|     | Voltage (VAC) | Resistive load (A) | Motor load (A) | Approvals ENEC |       | Approvals UL |       | Motor load |        |
|-----|---------------|--------------------|----------------|----------------|-------|--------------|-------|------------|--------|
|     |               |                    |                | (A)            | (VAC) | (A)          | (VAC) |            |        |
| XCF | 250           | 10                 | 3              | 10 (3)         | 1E4   | 250          | 10,1  | 125/250    | 1/4 HP |
| XCG | 250           | 6                  | 2              | 6 (2)          | 5E4   | 250          | 5     | 250        | -      |
| XCK | 250           | 5                  | 3              | 5 (3)          | 1E4   | 250          | 5     | 250        | -      |
| XCC | 250           | 3                  | 1              | 3 (1)          | 5E4   | 250          | 2     | 250        | -      |
| XCH | 250           | 1,5                | 0,3            | 1,5 (0,3)      | 5E4   | 250          | 1     | 250        | -      |

Breaking capacities in the tables refer to Ag contacts.

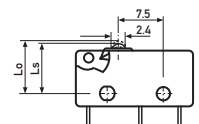
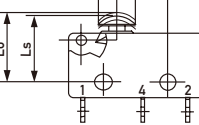
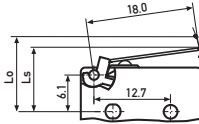
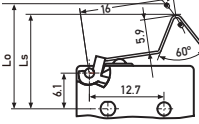
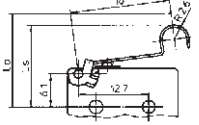
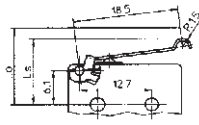
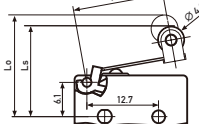
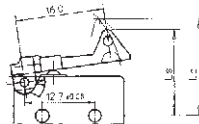
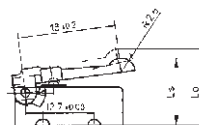

## Operating Characteristics

| Actuator  | Reference | Actuating Force |       | Release Force |       | Free Position |      | Operating Position |  | Movement Differential  |  | Total travelled position  |  |               |       |       |       |       |
|---|-----------|-----------------|-------|---------------|-------|---------------|------|--------------------|--|--|--|---|--|---------------|-------|-------|-------|-------|
|   |           | Maximum (N)     | (ozf) | Minimum (N)   | (ozf) | Maximum (mm)  | (in) | (mm)               | (in)   | Maximum (mm)   | (in)   | Maximum (mm)  | (in)   |               |       |       |       |       |
|    | XCF..     | 3               | 10.70 | 0.5           | 1.78  | 8.8           | 0.34 | 8.4                | $\left. \begin{array}{l} +0.1 \\ -0.3 \end{array} \right\} \begin{array}{l} 0.33 \\ 0.33 \\ 0.33 \\ 0.33 \end{array}$                      | $\left. \begin{array}{l} +0.003 \\ -0.011 \end{array} \right\}$                | 0.1  | 0.003   | 7.7  | 0.303         |       |       |       |       |
|   | XCG..     | 1.7             | 6.07  | 0.3           | 1.07  | 8.8           | 0.34 | 8.4                |  |  | 0.33   | 0.1   | 0.003  | 7.7           | 0.303 |       |       |       |
|   | XCK..     | 1.2             | 4.28  | 0.2           | 0.71  | 8.8           | 0.34 | 8.4                |  |  | 0.33   | 0.1   | 0.003  | 7.7           | 0.303 |       |       |       |
|   | XCC..     | 0.6             | 2.14  | 0.1           | 0.36  | 8.8           | 0.34 | 8.4                |  |  | 0.33   | 0.1   | 0.003  | 7.7           | 0.303 |       |       |       |
|   | XCH..     | 0.35            | 1.24  | 0.07          | 0.24  | 8.8           | 0.34 | 8.4                |  |  | 0.33   | 0.1   | 0.003  | 7.7           | 0.303 |       |       |       |
|    | XCF..-U1  | 3               | 10.70 | 0.5           | 1.78  | 10.3          | 0.41 | 9.9                | $\left. \begin{array}{l} +0.1 \\ -0.3 \end{array} \right\} \begin{array}{l} 0.39 \\ 0.39 \\ 0.39 \\ 0.39 \end{array}$                      | $\left. \begin{array}{l} +0.003 \\ -0.011 \end{array} \right\}$                | 0.1  | 0.003   | 9.2  | 0.36          |       |       |       |       |
|   | XCG..-U1  | 1.7             | 6.07  | 0.3           | 1.07  | 10.3          | 0.41 | 9.9                |  |  | 0.39   | 0.1   | 0.003  | 9.2           | 0.36  |       |       |       |
|   | XCK..-U1  | 1.2             | 4.28  | 0.2           | 0.71  | 10.3          | 0.41 | 9.9                |  |  | 0.39   | 0.1   | 0.003  | 9.2           | 0.36  |       |       |       |
|   | XCC..-U1  | 0.6             | 2.14  | 0.1           | 0.36  | 10.3          | 0.41 | 9.9                |  |  | 0.39   | 0.1   | 0.003  | 9.2           | 0.36  |       |       |       |
|   | XCH..-U1  | 0.35            | 1.24  | 0.07          | 0.24  | 10.3          | 0.41 | 9.9                |  |  | 0.39   | 0.1   | 0.003  | 9.2           | 0.36  |       |       |       |
|    | XCF..     | 1.05            | 3.74  | 0.16          | 0.57  | 12.2          | 0.48 | 10.2 ± 1.0         | $\left. \begin{array}{l} 0.401 \pm 0.039 \\ 0.401 \pm 0.035 \\ 0.405 \pm 0.035 \\ 0.404 \pm 0.035 \\ 0.409 \pm 0.035 \end{array} \right\}$ | $\left. \begin{array}{l} 0.6 \\ 0.5 \\ 0.5 \\ 0.4 \\ 0.4 \end{array} \right\}$ | $\left. \begin{array}{l} 0.023 \\ 0.019 \\ 0.019 \\ 0.015 \\ 0.015 \end{array} \right\}$ | $\left. \begin{array}{l} 8.4 \\ 8.5 \\ 8.7 \\ 8.7 \\ 8.8 \end{array} \right\}$      | $\left. \begin{array}{l} 0.33 \\ 0.337 \\ 0.342 \\ 0.342 \\ 0.346 \end{array} \right\}$  |               |       |       |       |       |
|   | XCG..     | 0.6             | 2.14  | 0.08          | 0.28  | 12.2          | 0.48 | 10.2 ± 0.9         |  |  |  |   |  | 0.401 ± 0.035 | 0.5   | 0.019 | 8.5   | 0.337 |
|   | XCK..     | 0.42            | 1.49  | 0.056         | 0.19  | 12.2          | 0.48 | 10.3 ± 0.9         |  |  |  |   |  | 0.405 ± 0.035 | 0.5   | 0.019 | 8.7   | 0.342 |
|   | XCC..     | 0.22            | 0.78  | 0.025         | 0.08  | 12.2          | 0.48 | 10.3 ± 0.9         |  |  |  |   |  | 0.404 ± 0.035 | 0.4   | 0.015 | 8.7   | 0.342 |
|   | XCH..     | 0.13            | 0.46  | 0.02          | 0.07  | 12.2          | 0.48 | 10.4 ± 0.9         |  |  |  |   |  | 0.409 ± 0.035 | 0.4   | 0.015 | 8.8   | 0.346 |
| Width of lever 4.0 mm/0.16 in   |           |                 |       |               |       |               |      |                    |  |  |  |   |  |               |       |       |       |       |
|   | XCF..     | 1.1             | 3.92  | 0.17          | 0.6   | 17.6          | 0.69 | 15.6 ± 1.1         | $\left. \begin{array}{l} 0.614 \pm 0.043 \\ 0.614 \pm 0.039 \\ 0.618 \pm 0.039 \\ 0.618 \pm 0.039 \\ 0.622 \pm 0.039 \end{array} \right\}$ | $\left. \begin{array}{l} 0.6 \\ 0.5 \\ 0.4 \\ 0.4 \\ 0.4 \end{array} \right\}$ | $\left. \begin{array}{l} 0.023 \\ 0.019 \\ 0.015 \\ 0.015 \\ 0.015 \end{array} \right\}$ | $\left. \begin{array}{l} 14 \\ 14.1 \\ 14.3 \\ 14.3 \\ 14.4 \end{array} \right\}$   | $\left. \begin{array}{l} 0.551 \\ 0.555 \\ 0.562 \\ 0.562 \\ 0.566 \end{array} \right\}$ |               |       |       |       |       |
|   | XCG..     | 0.7             | 2.49  | 0.09          | 0.32  | 17.6          | 0.69 | 15.6 ± 1.0         |  |  |  |   |  | 0.614 ± 0.039 | 0.5   | 0.019 | 14.1  | 0.555 |
|   | XCK..     | 0.43            | 1.53  | 0.058         | 0.2   | 17.6          | 0.69 | 15.7 ± 1.0         |  |  |  |   |  | 0.618 ± 0.039 | 0.4   | 0.015 | 14.3  | 0.562 |
|   | XCC..     | 0.23            | 0.82  | 0.026         | 0.09  | 17.6          | 0.69 | 15.7 ± 1.0         |  |  |  |   |  | 0.618 ± 0.039 | 0.4   | 0.015 | 14.3  | 0.562 |
|   | XCH..     | 0.14            | 0.49  | 0.021         | 0.07  | 17.6          | 0.69 | 15.8 ± 1.0         |  |  |  |   |  | 0.622 ± 0.039 | 0.4   | 0.015 | 14.4  | 0.566 |
| Width of lever 4.0 mm/0.16 in   |           |                 |       |               |       |               |      |                    |  |  |  |   |  |               |       |       |       |       |
|  | XCF..     | 1.05            |       | 0.16          |       | 17.1          |      | 15.1 ± 1.1         | $\left. \begin{array}{l} 0.6 \\ 0.5 \\ 0.5 \\ 0.4 \\ 0.4 \end{array} \right\}$   | $\left. \begin{array}{l} 0.6 \\ 0.5 \\ 0.5 \\ 0.4 \\ 0.4 \end{array} \right\}$ | $\left. \begin{array}{l} 0.023 \\ 0.019 \\ 0.015 \\ 0.015 \\ 0.015 \end{array} \right\}$ | $\left. \begin{array}{l} 13.3 \\ 13.4 \\ 13.6 \\ 13.6 \\ 13.7 \end{array} \right\}$ | $\left. \begin{array}{l} 0.33 \\ 0.337 \\ 0.342 \\ 0.342 \\ 0.346 \end{array} \right\}$  |               |       |       |       |       |
|   | XCG..     | 0.6             |       | 0.08          |       | 17.1          |      | 15.1 ± 1.0         |  |  |  |   |  | 0.6           | 0.023 | 13.3  | 0.33  |       |
|   | XCK..     | 0.42            |       | 0.056         |       | 17.1          |      | 15.2 ± 1.0         |  |  |  |   |  | 0.5           | 0.019 | 13.4  | 0.337 |       |
|   | XCC..     | 0.22            |       | 0.025         |       | 17.1          |      | 15.2 ± 1.0         |  |  |  |   |  | 0.5           | 0.019 | 13.6  | 0.342 |       |
|   | XCH..     | 0.13            |       | 0.02          |       | 17.1          |      | 15.3 ± 1.0         |  |  |  |   |  | 0.4           | 0.015 | 13.6  | 0.342 |       |
| Width of lever 4.0 mm/0.16 in   |           |                 |       |               |       |               |      |                    |  |  |  |   |  |               |       |       |       |       |
|  | XCF..     | 1.05            |       | 0.16          |       | 13.7          |      | 11.7 ± 1.1         | $\left. \begin{array}{l} 0.6 \\ 0.5 \\ 0.5 \\ 0.4 \\ 0.4 \end{array} \right\}$   | $\left. \begin{array}{l} 0.6 \\ 0.5 \\ 0.5 \\ 0.4 \\ 0.4 \end{array} \right\}$ | $\left. \begin{array}{l} 0.023 \\ 0.019 \\ 0.015 \\ 0.015 \\ 0.015 \end{array} \right\}$ | $\left. \begin{array}{l} 9.9 \\ 10.0 \\ 10.2 \\ 10.2 \\ 10.3 \end{array} \right\}$  | $\left. \begin{array}{l} 0.33 \\ 0.337 \\ 0.342 \\ 0.342 \\ 0.346 \end{array} \right\}$  |               |       |       |       |       |
|   | XCG..     | 0.6             |       | 0.08          |       | 13.7          |      | 11.7 ± 1.0         |  |  |  |   |  | 0.6           | 0.023 | 9.9   | 0.33  |       |
|   | XCK..     | 0.42            |       | 0.056         |       | 13.7          |      | 11.8 ± 1.0         |  |  |  |   |  | 0.5           | 0.019 | 10.0  | 0.337 |       |
|   | XCC..     | 0.22            |       | 0.025         |       | 13.7          |      | 11.8 ± 1.0         |  |  |  |   |  | 0.5           | 0.019 | 10.2  | 0.342 |       |
|   | XCH..     | 0.13            |       | 0.02          |       | 13.7          |      | 11.9 ± 1.0         |  |  |  |   |  | 0.4           | 0.015 | 10.2  | 0.342 |       |
| Width of lever 4.0 mm/0.16 in   |           |                 |       |               |       |               |      |                    |  |  |  |   |  |               |       |       |       |       |
|  | XCF..     | 1.1             | 3.92  | 0.17          | 0.6   | 17.6          | 0.69 | 15.6 ± 1.2         | $\left. \begin{array}{l} 0.614 \pm 0.047 \\ 0.614 \pm 0.043 \\ 0.618 \pm 0.043 \\ 0.618 \pm 0.043 \\ 0.622 \pm 0.043 \end{array} \right\}$ | $\left. \begin{array}{l} 0.6 \\ 0.5 \\ 0.4 \\ 0.4 \\ 0.4 \end{array} \right\}$ | $\left. \begin{array}{l} 0.023 \\ 0.019 \\ 0.015 \\ 0.015 \\ 0.015 \end{array} \right\}$ | $\left. \begin{array}{l} 14.1 \\ 14.2 \\ 14.4 \\ 14.4 \\ 14.5 \end{array} \right\}$ | $\left. \begin{array}{l} 0.555 \\ 0.559 \\ 0.566 \\ 0.566 \\ 0.57 \end{array} \right\}$  |               |       |       |       |       |
|   | XCG..     | 0.7             | 2.49  | 0.09          | 0.32  | 17.6          | 0.69 | 15.6 ± 1.1         |  |  |  |   |  | 0.614 ± 0.043 | 0.6   | 0.023 | 14.1  | 0.555 |
|   | XCK..     | 0.43            | 1.53  | 0.058         | 0.2   | 17.6          | 0.69 | 15.7 ± 1.1         |  |  |  |   |  | 0.618 ± 0.043 | 0.5   | 0.019 | 14.2  | 0.559 |
|   | XCC..     | 0.23            | 0.82  | 0.026         | 0.09  | 17.6          | 0.69 | 15.7 ± 1.1         |  |  |  |   |  | 0.618 ± 0.043 | 0.4   | 0.015 | 14.4  | 0.566 |
|   | XCH..     | 0.14            | 0.49  | 0.021         | 0.07  | 17.6          | 0.69 | 15.8 ± 1.1         |  |  |  |   |  | 0.622 ± 0.043 | 0.4   | 0.015 | 14.4  | 0.566 |
| Width of roller 4.0 mm/0.16 in. for high temperature use -T1 lever                  |           |                 |       |               |       |               |      |                    |  |  |  |   |  |               |       |       |       |       |
|  | XCF..     | 1.3             | 4.62  | 0.17          | 0.6   | 17.6          | 0.69 | 15.6 ± 1.1         | $\left. \begin{array}{l} 0.614 \pm 0.043 \\ 0.614 \pm 0.039 \\ 0.618 \pm 0.039 \\ 0.618 \pm 0.043 \\ 0.622 \pm 0.039 \end{array} \right\}$ | $\left. \begin{array}{l} 0.6 \\ 0.5 \\ 0.4 \\ 0.4 \\ 0.4 \end{array} \right\}$ | $\left. \begin{array}{l} 0.023 \\ 0.019 \\ 0.015 \\ 0.015 \\ 0.015 \end{array} \right\}$ | $\left. \begin{array}{l} 14 \\ 14.1 \\ 14.3 \\ 14.3 \\ 14.4 \end{array} \right\}$   | $\left. \begin{array}{l} 0.551 \\ 0.555 \\ 0.562 \\ 0.562 \\ 0.566 \end{array} \right\}$ |               |       |       |       |       |
|   | XCG..     | 0.75            | 2.67  | 0.09          | 0.32  | 17.6          | 0.69 | 15.6 ± 1.0         |  |  |  |   |  | 0.614 ± 0.039 | 0.6   | 0.023 | 14    | 0.551 |
|   | XCK..     | 0.6             | 2.13  | 0.058         | 0.2   | 17.6          | 0.69 | 15.7 ± 1.0         |  |  |  |   |  | 0.618 ± 0.039 | 0.5   | 0.019 | 14.1  | 0.555 |
|   | XCC..     | 0.31            | 1.10  | 0.026         | 0.09  | 17.6          | 0.69 | 15.7 ± 1.1         |  |  |  |   |  | 0.618 ± 0.043 | 0.4   | 0.015 | 14.3  | 0.562 |
|   | XCH..     | 0.22            | 0.78  | 0.021         | 0.07  | 17.6          | 0.69 | 15.8 ± 1.0         |  |  |  |   |  | 0.622 ± 0.039 | 0.4   | 0.015 | 14.3  | 0.562 |
| Width of roller 4.0 mm/0.16 in. for high temperature use -T1 lever                  |           |                 |       |               |       |               |      |                    |  |  |  |   |  |               |       |       |       |       |
|  | XCF..     | 1.05            | 3.74  | 0.16          | 0.57  | 14.3          | 0.56 | 12.5 ± 1.1         | $\left. \begin{array}{l} 0.49 \pm 0.043 \\ 0.49 \pm 0.039 \\ 0.5 \pm 0.039 \\ 0.5 \pm 0.039 \\ 0.5 \pm 0.039 \end{array} \right\}$         | $\left. \begin{array}{l} 0.6 \\ 0.5 \\ 0.5 \\ 0.4 \\ 0.4 \end{array} \right\}$ | $\left. \begin{array}{l} 0.023 \\ 0.019 \\ 0.015 \\ 0.015 \\ 0.015 \end{array} \right\}$ | $\left. \begin{array}{l} 10.6 \\ 10.7 \\ 10.8 \\ 10.8 \\ 10.9 \end{array} \right\}$ | $\left. \begin{array}{l} 0.417 \\ 0.421 \\ 0.425 \\ 0.425 \\ 0.429 \end{array} \right\}$ |               |       |       |       |       |
|   | XCG..     | 0.6             | 2.13  | 0.08          | 0.28  | 14.3          | 0.56 | 12.5 ± 1.0         |  |  |  |   |  | 0.49 ± 0.039  | 0.6   | 0.023 | 10.6  | 0.417 |
|   | XCK..     | 0.42            | 1.49  | 0.056         | 0.21  | 14.3          | 0.56 | 12.6 ± 1.0         |  |  |  |   |  | 0.49 ± 0.039  | 0.5   | 0.019 | 10.7  | 0.421 |
|   | XCC..     | 0.22            | 0.78  | 0.025         | 0.11  | 14.3          | 0.56 | 12.6 ± 1.0         |  |  |  |   |  | 0.5 ± 0.039   | 0.5   | 0.015 | 10.8  | 0.425 |
|   | XCH..     | 0.13            | 0.46  | 0.02          | 0.07  | 14.3          | 0.56 | 12.7 ± 1.0         |  |  |  |   |  | 0.5 ± 0.039   | 0.4   | 0.015 | 10.8  | 0.425 |

## Ordering Reference

|            |  |   |                   |              |   |   |   |     |     |    |
|------------|--|---|-------------------|--------------|---|---|---|-----|-----|----|
| Basic type | XCF  | 3 N   | 10,7 ozf          | Example: XCF | 4 | 3 | V | -81 | -J1 | Z1 |
|            | XCG  | 1,7 N   | 6,07 ozf          |              |   |   |   |     |     |    |
|            | XCK  | 1,2 N   | 4,28 ozf          |              |   |   |   |     |     |    |
|            | XCC  | 0,6 N   | 2,14 ozf          |              |   |   |   |     |     |    |
|            | XCH  | 0,35 N  | 1,24 ozf          |              |   |   |   |     |     |    |
| Circuits   | No symbol, change-over   |   |                   |              |   |   |   |     |     |    |
|            | 4  | Normally closed (NC)  |                   |              |   |   |   |     |     |    |
|            | 5  | Normally open (NO)  |                   |              |   |   |   |     |     |    |
| Terminals  | 3  | Solder  |                   |              |   |   |   |     |     |    |
|            | 4  | plug 2.8 × 0.5 mm DIN   |                   |              |   |   |   |     |     |    |
|            | 5  | plug 2.8 × 0.5 mm AMP   |                   |              |   |   |   |     |     |    |
|            | 8  | PCB, L = 4,5 mm   |                   |              |   |   |   |     |     |    |
|            | 9  | PCB, 1/10" pitch, L = 4.5 mm  |                   |              |   |   |   |     |     |    |
|            | 10   | PCB, formed to base   |                   |              |   |   |   |     |     |    |
|            | 11   | PCB, formed to lid  |                   |              |   |   |   |     |     |    |
|            | 12   | PCB, formed to base, 1/10" pitch  |                   |              |   |   |   |     |     |    |
|            | 13   | PCB, formed to lid, 1/10" pitch   |                   |              |   |   |   |     |     |    |
|            | 14   | PCB, L = 3.5 mm   |                   |              |   |   |   |     |     |    |
|            | 15   | PCB, 1/10" pitch, L = 3.5 mm  |                   |              |   |   |   |     |     |    |
| Version    | No symbol, Housing material MF, Europe up to 85°C, UL up to 90°C |   |                   |              |   |   |   |     |     |    |
|            | V  | (High temperature 125°C), Housing material MF / Plunger PBT, Europe up to 125°C, UL up to 130°C |                   |              |   |   |   |     |     |    |
|            | W  | (High temperature 140°C), Housing material MF / Plunger PPS, Europe up to 140°C, UL up to 150°C |                   |              |   |   |   |     |     |    |
| Contacts   | No symbol, Ag (Ag)   |   |                   |              |   |   |   |     |     |    |
|            | -81  | μ profile Au 10 μm  |                   |              |   |   |   |     |     |    |
| Actuators  | No symbol, plunger   |   |                   |              |   |   |   |     |     |    |
|            | -J1  | Plain lever   | 18,0 mm (0.71 in) |              |   |   |   |     |     |    |
|            | -J2  | Plain lever   | 25,0 mm (0.98 in) |              |   |   |   |     |     |    |
|            | -J5  | Plain lever   | 40,0 mm (1.57 in) |              |   |   |   |     |     |    |
|            | -S1  | Roller lever  | 16,0 mm (0.63 in) |              |   |   |   |     |     |    |
|            | -L1  | Cam follower  | 16,0 mm (0.63 in) |              |   |   |   |     |     |    |
|            | -L6  | Cam follower  | 18,0 mm (0.71 in) |              |   |   |   |     |     |    |
|            | -L9  | Cam follower  | 18,5 mm (0.73 in) |              |   |   |   |     |     |    |
|            | -P5  | Plastic lever   | 16,0 mm (0.63 in) |              |   |   |   |     |     |    |
|            | -P6  | Plastic lever   | 18,0 mm (0.71 in) |              |   |   |   |     |     |    |
|            | -U1  | Mushroom plunger  |                   |              |   |   |   |     |     |    |
|            | Other actuators on special request.                              |   |                   |              |   |   |   |     |     |    |
| Approvals  | No symbol, ENEC  |   |                   |              |   |   |   |     |     |    |
|            | Z1   | UL, CSA   |                   |              |   |   |   |     |     |    |

## Thermoplastic Microswitches



Circuit diagram

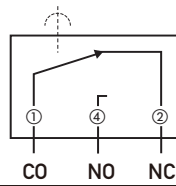

Dimension

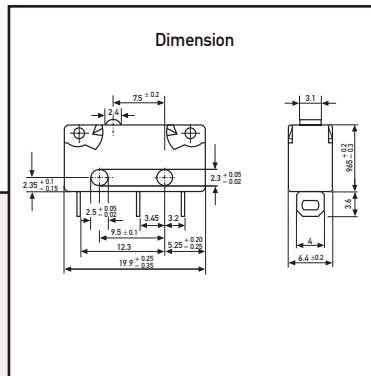

# X4

## X4

- Characteristics
- thermoplastic housing
  - long mechanical and electrical life
  - solder, PCB and faston terminals

Rating 250 VAC, 12 A max.

Dimensions (mm) 19.9 × 9.7 × 6.4

- Actuator
- plunger
  - plain levers
  - cam follower lever
  - roller levers

Approvals UL, cUL, CSA, ENEC, CQC



## Preferred Range

| Ordering Reference | Actuating Force |        | Operating pos.<br>(mm) | Terminal | Circuit | Actuator | Contacts | Electrical rating |        |
|--------------------|-----------------|--------|------------------------|----------|---------|----------|----------|-------------------|--------|
|                    | (N)             | (ozf)  |                        |          |         |          |          | ENEC              | UL/CSA |
| X4F303K1AA         | 3.3             | 11,869 | 8,4                    | Solder   | CO      | Plunger  | Ag       | 12 (6) A          | 12 A   |
| X4F305K1AA         | 3.3             | 11,869 | 8,4                    | Faston   | CO      | Plunger  | Ag       | 12 (6) A          | 12 A   |
| X4G303K1BB         | 2               | 7,193  | 8,4                    | Solder   | CO      | Plunger  | Ag       | 6 (3) A           | 6 A    |
| X4G305K1BB         | 2               | 7,193  | 8,4                    | Faston   | CO      | Plunger  | Ag       | 6 (3) A           | 6 A    |
| X4C303K1CC         | 0,75            | 2,697  | 8,4                    | Solder   | CO      | Plunger  | Ag       | 3 (2) A           | 3 A    |
| X4C305K1CC         | 0,75            | 2,697  | 8,4                    | Faston   | CO      | Plunger  | Ag       | 3 (2) A           | 3 A    |

## Specifications

|                      |   |
|----------------------|---|
| Housing              | Thermoplastic   |
| Plunger              | Thermoplastic   |
| Mechanism            | Snap-action system with stainless steel tension spring                  |
| Functions            | Change-over, NO, NC.  |
| Contacts             | Fine silver (Ag), or 10 µm Gold (Au), microprofile                      |
| Terminals            | Solder, faston, PCB, side-facing PCB and 'PCB terminals with 0.1" pitch |
| Temperature range °C | Between -40°C and +85°C   |
| Mechanical life      | 10 <sup>6</sup> cycles minimum  |
| Protection           | Enclosure – IP 40   |
| Mounting             | Side mounting or PCB  |
| Actuators            | Stainless steel, PA66–GF35  |
| Contact carrier      | CuZn or CuSn  |

Circuit diagram

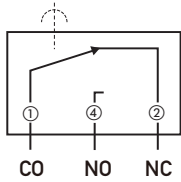

Actuating force/travel

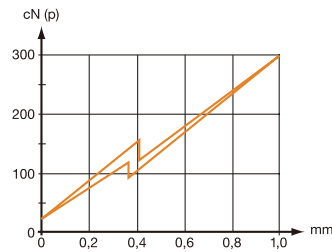

Contact force/travel

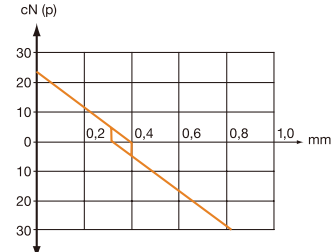

Dimensions

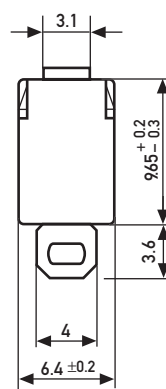
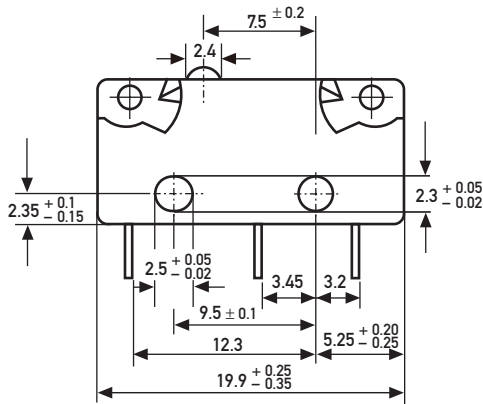

Maximum DC rating

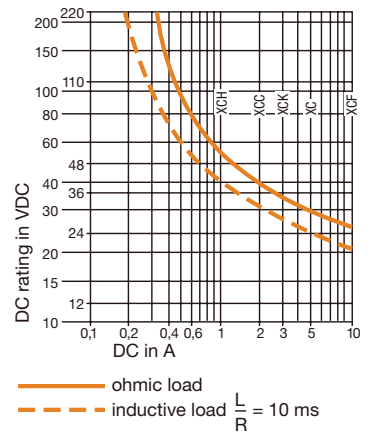

## Recommended maximum electrical ratings

|     | Voltage (VAC) | Resistive load (A) | Motor load (A) | Approvals ENEC (A) |       | Approvals UL (VAC) |            |
|-----|---------------|--------------------|----------------|--------------------|-------|--------------------|------------|
|     |               |                    |                |                    | (VAC) | (A)                | (VAC)      |
| X4F | 250           | 12                 | 6              | 12 (6)             | 1E4   | 250                | 12 125/250 |
| X4G | 250           | 6                  | 3              | 6 (3)              | 5E4   | 250                | 6 125/250  |
| X4C | 250           | 3                  | 2              | 3 (2)              | 5E4   | 250                | 3 125/250  |

Breaking capacities in the tables refer to silver contacts



## Ordering Reference

|                   |    |  |    |  |                   |  |  |  |    |  |                   |                               |    |                             |    |   |    |  |    |                             |    |  |    |   |    |  |    |   |    |   |
|-------------------|----|--|----|--|-------------------|--|--|--|----|--|-------------------|-------------------------------|----|-----------------------------|----|---|----|--|----|-----------------------------|----|--|----|---|----|--|----|---|----|---|
| Basic type        | X4 | Example: X4                                | F  | 3  | 03                | K  | 1  | A  | A  | J1                                       | 1                 |                               |    |                             |    |   |    |  |    |                             |    |  |    |   |    |  |    |   |    |   |
| Operating force   | F  | extra high force                           | G  | high force   | C                 | low force  |  |  |    |  |                   |                               |    |                             |    |   |    |  |    |                             |    |  |    |   |    |  |    |   |    |   |
| Circuits diagram  | 3  | Change-over (CO)                           | 4  | Normally closed (NC)   | 5                 | Normally open (NO)                                     | } with X4F and X4G not possible (except gold contacts) |  |    |  |                   |                               |    |                             |    |   |    |  |    |                             |    |  |    |   |    |  |    |   |    |   |
| Terminals         | 03 | Solder terminal                            | 04 | Faston terminal 2.8 × 0.5 mm DIN   | 05                | Faston terminal 2.8 × 0.5 mm                           | 08   | PCB-terminal, length 4.5 mm  | 09 | PCB-terminal, length 4.5 mm, (pitch 7.6) | 10                | PCB-terminal, formed to base  | 11 | PCB-terminal, formed to lid | 12 | PCB-terminal, formed to base, (pitch 7.6) | 13 | PCB-terminal, formed to lid, (pitch 7.6) | 14 | PCB-terminal, length 3.5 mm | 15 | PCB-terminal, length 3.5 mm, (pitch 7.6) | 21 | Equidistant PCB-terminals, length 8.15 mm (pitch 7.5) | 22 | Equidistant PCB-terminals formed to base (pitch 7.5) | 23 | Equidistant PCB-terminals formed to lid (pitch 7.5) | 24 | Equidistant faston terminals 2.8 × 0.5 mm DIN (pitch 7.5) |
| Body              | K  | Ultradid, for terminal types 03 to 15 only | N  | Latamid, compliant to glow wire requirements as to IEC 60335-1, 4. ed., for terminal types 03 to 15 only | M                 | Ultradid, for equidistant terminal types 21 to 24 only | R  | Ultradid, with moulded pegs, for equidistant terminal types 22 and 23 only |    |  |                   |                               |    |                             |    |   |    |  |    |                             |    |  |    |   |    |  |    |   |    |   |
| Contacts material | 1  | Silver/Silver                              | 8  | Gold microprofile (Crosspoint) contacts  | 9                 | Gold-plated  |  |  |    |  |                   |                               |    |                             |    |   |    |  |    |                             |    |  |    |   |    |  |    |   |    |   |
| UL/C-UL ratings   | A  | 12 A, 125/250 VAC                          | B  | 6 A, 125/250 VAC   | C                 | 3 A, 125/250 VAC                                       | D  | 0.1 A, 125 VAC   | N  | no approvals                             |                   |                               |    |                             |    |   |    |  |    |                             |    |  |    |   |    |  |    |   |    |   |
| EN/IEC ratings    | A  | 12 (6) A, 250 V~ 1E4 T85 μ approved        | B  | 6 (3) A, 250 V~ 5E4 T85 μ approved   | C                 | 3 (2) A, 250 V~ 5E4 T85 μ approved                     | F  | 10 (4) A, 250 V~ 1E4 T125 μ approved                                       | L  | 1 A, 30 V = not approved                 | M                 | 0.3 A, 30 V~ 1E4 not approved |    |                             |    |   |    |  |    |                             |    |  |    |   |    |  |    |   |    |   |
| Type of actuators |    | No symbol, without lever                   | J1 | Plain lever  | 18.0 mm (0.71 in) | L1   | Cam follower   | 16.0 mm (0.63 in)  | S1 | Roller lever                             | 16.0 mm (0.63 in) |                               |    |                             |    |   |    |  |    |                             |    |  |    |   |    |  |    |   |    |   |
|                   |    | Other actuators on special request         |    |  |                   |  |  |  |    |  |                   |                               |    |                             |    |   |    |  |    |                             |    |  |    |   |    |  |    |   |    |   |
| Actuator position |    | No symbol, without lever                   | 1  | Lever above terminal 1   | 2                 | Lever above terminal 2                                 |  |  |    |  |                   |                               |    |                             |    |   |    |  |    |                             |    |  |    |   |    |  |    |   |    |   |

# Sealed and unsealed Microswitches

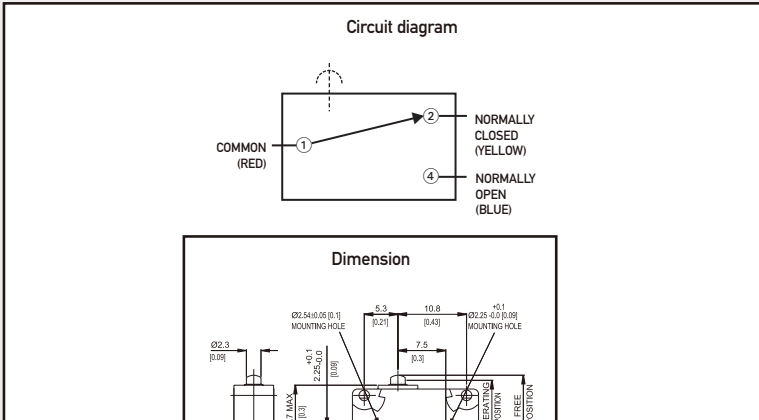



# V4N

## V4N

Characteristics ■ sealed (IP67)  
 ■ solder, 2.8 mm faston and PCB terminals  
 ■ pre-wired option

Rating 250 VAC, 5 A

Dimensions (mm) 20 × 10.3 × 6.4

Actuator ■ plunger  
 ■ plain levers  
 ■ roller levers  
 ■ simulated roller lever/cam follower

Approvals UL, CSA, ENEC



## Preferred Range

| Ordering Reference | Actuating Force<br>(N) (ozf) |     | Sealing | Operating pos.<br>(mm) (in) |      | Terminal  | Circuit | Actuator       | Contacts | Electrical rating |
|--------------------|------------------------------|-----|---------|-----------------------------|------|-----------|---------|----------------|----------|-------------------|
| V4NT7UL            | 1.40                         | 5.0 | IP40    | 8.40                        | 0.33 | Solder    | CO      | Plain plunger  | Ag       | 250 VAC, 5 A      |
| V4NST7UL           | 2.50                         | 9.0 | IP67    | 8.40                        | 0.33 | Solder    | CO      | Plain plunger  | Ag       | 250 VAC, 5 A      |
| V4NSUL             | 2.50                         | 9.0 | IP67    | 8.40                        | 0.33 | Pre-wired | CO      | Plain plunger  | Ag       | 250 VAC, 5 A      |
| V4NT7Y1UL          | 0.50                         | 1.8 | IP40    | 10.7                        | 0.42 | Solder    | CO      | Straight lever | Ag       | 250 VAC, 5 A      |
| V4NST7Y1UL         | 0.90                         | 3.2 | IP67    | 10.6                        | 0.42 | Solder    | CO      | Straight lever | Ag       | 250 VAC, 5 A      |
| V4NSY1UL           | 0.90                         | 3.2 | IP67    | 10.6                        | 0.42 | Pre-wired | CO      | Straight lever | Ag       | 250 VAC, 5 A      |
| V4NT7YRUL          | 0.50                         | 1.8 | IP40    | 15.7                        | 0.62 | Solder    | CO      | Roller lever   | Ag       | 250 VAC, 5 A      |
| V4NST7YRUL         | 0.90                         | 3.2 | IP67    | 15.6                        | 0.62 | Solder    | CO      | Roller lever   | Ag       | 250 VAC, 5 A      |
| V4NSYRUL           | 0.90                         | 3.2 | IP67    | 15.6                        | 0.62 | Pre-wired | CO      | Roller lever   | Ag       | 250 VAC, 5 A      |

## Specifications

|                      |   |
|----------------------|---|
| Housing              | Flame-retardant glass-fibre reinforced nylon  |
| Plunger              | Polyacetal (POM)  |
| Mechanism            | Snap-action coil spring mechanism with stainless steel spring                               |
| Functions            | Change-over, normally closed or normally open   |
| Contacts             | Silver  |
| Terminals            | Gold flashed  |
| Temperature range °C | -40°C to +85°C  |
| Mechanical life      | 5 × 10 <sup>6</sup> cycles minimum (impact free actuation) for the cowl 3 × 10 <sup>6</sup> |
| Protection           | IP40 (V4N - enclosure), IP67 (V4NS - enclosure)   |
| Mounting             | Side mounting   |
| Actuators            | Plain lever, cam follower, Roller lever   |
| Accessories          | Insulating sheet - N04619, Clip-on terminal cover - TC102, Long overtravel actuator - QA4   |

Circuit diagram

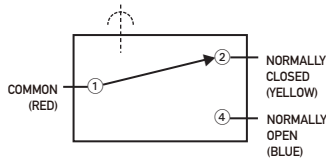

Dimensions

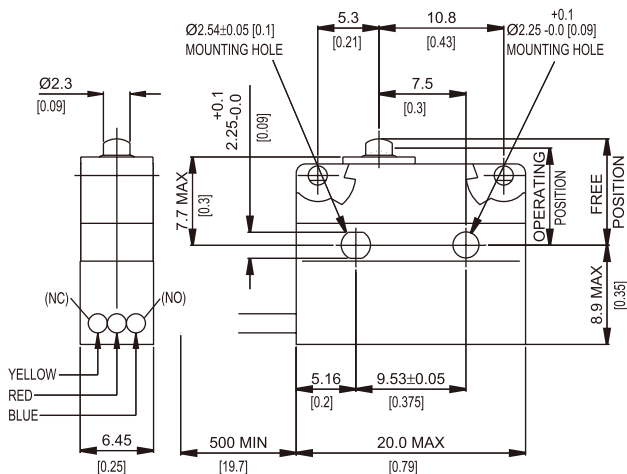

## Recommended maximum electrical ratings

|                      | Voltage (max) | Load (A)    | Inductive load (A) | Approval   |
|----------------------|---------------|-------------|--------------------|--|
| V4NT7UL/<br>V4NST7UL | 250 VAC       | 5 (0.75 pf) |                    | UL 1054/CSA 22.2 No. 55 - 6,000 operations - 65°C<br>EN61058-1, T85, 10,000 operations |
|                      | 250 VAC       | 5           | 2                  |  |
|                      | 0 - 15 VDC    | 5           | 3                  | General rating - 50,000 operations (85°C)  |
|                      | 15 - 30 VDC   | 5           | 3                  | General rating - 50,000 operations (85°C)  |
| V4NSUL               | 250 VAC       | 3 (0.75 pf) |                    | UL 1054/CSA 22.2 No. 55 - 6,000 operations - 65°C<br>EN61058-1, T85, 10,000 operations |
|                      | 250 VAC       | 5           | 2                  |  |
|                      | 0 - 15 VDC    | 3           | 3                  | General rating - 50,000 operations (85°C)  |
|                      | 15 - 30 VDC   | 3           | 3                  | General rating - 50,000 operations (85°C)  |

## Operating Characteristics

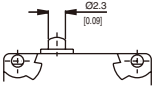
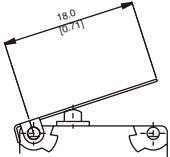
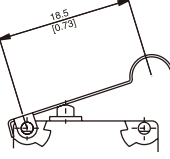
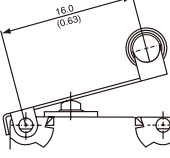
| Actuator  | Reference  | Actuating Force |       | Release Force |       | Free Position |      | Operating Position |              | Movement Differential |       |
|---|------------|-----------------|-------|---------------|-------|---------------|------|--------------------|--------------|-----------------------|-------|
|   |            | Maximum (N)     | (ozf) | Minimum (N)   | (ozf) | Maximum (mm)  | (in) | (mm)               | (in)         | Maximum (mm)          | (in)  |
| Plunger<br>    | V4NT7UL    | 1,4             | 5,00  | 0,28          | 1,00  | 9,2           | 0,36 | 8,4 ± 0,3          | 0,33 ± 0,012 | 0,1                   | 0,004 |
|   | V4NST7UL   | 2,5             | 9,00  | 0,30          | 1,00  | 9,2           | 0,36 | 8,4 ± 0,3          | 0,33 ± 0,012 | 0,1                   | 0,004 |
|   | V4NSUL     | 2,5             | 9,00  | 0,3           | 1,00  | 9,2           | 0,36 | 8,4 ± 0,3          | 0,33 ± 0,012 | 0,1                   | 0,004 |
| Y1 lever<br>   | V4NT7Y1UL  | 0,5             | 1,80  | 0,07          | 0,25  | 13,2          | 0,52 | 10,7 ± 1,0         | 0,42 ± 0,04  | 0,4                   | 0,016 |
|   | V4NST7Y1UL | 0,9             | 3,20  | 0,07          | 0,25  | 13,2          | 0,52 | 10,6 ± 1,2         | 0,42 ± 0,05  | 0,4                   | 0,016 |
|   | V4NSY1UL   | 0,9             | 3,20  | 0,07          | 0,25  | 13,2          | 0,52 | 10,6 ± 1,2         | 0,42 ± 0,05  | 0,4                   | 0,016 |
| Width of lever 4.0 mm/0.16 in   |            |                 |       |               |       |               |      |                    |              |                       |       |
| YC lever<br>  | V4NT7YCUL  | 0,5             | 1,80  | 0,07          | 0,25  | 17,8          | 0,70 | 15,7 ± 1,0         | 0,62 ± 0,04  | 0,4                   | 0,016 |
|   | V4NST7YCUL | 0,9             | 3,20  | 0,07          | 0,25  | 17,8          | 0,70 | 15,6 ± 1,2         | 0,61 ± 0,05  | 0,4                   | 0,016 |
|   | V4NSYCUL   | 0,9             | 3,20  | 0,07          | 0,25  | 17,8          | 0,70 | 15,6 ± 1,2         | 0,61 ± 0,05  | 0,4                   | 0,016 |
| Width of lever 4.0 mm/0.16 in   |            |                 |       |               |       |               |      |                    |              |                       |       |
| YR lever<br> | V4NT7YRUL  | 0,5             | 1,80  | 0,07          | 0,25  | 17,8          | 0,70 | 15,7 ± 1,0         | 0,62 ± 0,04  | 0,4                   | 0,016 |
|   | V4NST7YRUL | 0,9             | 3,20  | 0,07          | 0,25  | 17,8          | 0,70 | 15,6 ± 1,2         | 0,61 ± 0,05  | 0,4                   | 0,016 |
|   | V4NSYRUL   | 0,9             | 3,20  | 0,07          | 0,25  | 17,8          | 0,70 | 15,6 ± 1,2         | 0,61 ± 0,05  | 0,4                   | 0,016 |
| Width of lever 4.0 mm/0.16 in   |            |                 |       |               |       |               |      |                    |              |                       |       |

Over travel: Plunger can be depressed flush with housing. The housing should not be used as an end stop.

## Ordering Reference

| Basic type                         |   | Example: V4N |    |    |    |   |   |    |
|------------------------------------|---|--------------|----|----|----|---|---|----|
|                                    |   | E            | T6 | C2 | Y1 | 0 | G | UL |
| Type of sealing/<br>Overtravel     | No symbol, unsealed, standard travel  |              |    |    |    |   |   |    |
| E                                  | Unsealed with extended overtravel (0.5 mm)  |              |    |    |    |   |   |    |
| S                                  | Sealed IP67 standard travel   |              |    |    |    |   |   |    |
| B                                  | Sealed IP67 with extended overtravel (0.5 mm)   |              |    |    |    |   |   |    |
| Terminals                          | No symbol, pre-wired 500 mm with cable box K2 (V4NS/B only)   |              |    |    |    |   |   |    |
| T6                                 | Faston 2.03 × 0.5 × 6.6 long  |              |    |    |    |   |   |    |
| T7                                 | Solder 2.95 × 0.5 × 3.6 long  |              |    |    |    |   |   |    |
| T8                                 | PCB 0.8 × 0.5 × 4.0 long  |              |    |    |    |   |   |    |
| T9                                 | Faston 2.8 × 0.5 × 8.1 long   |              |    |    |    |   |   |    |
| T81                                | Formed PCB 0.8 × 0.5 × 3.8 long   |              |    |    |    |   |   |    |
| T82                                | Formed PCB 0.8 × 0.5 × 3.8 long   |              |    |    |    |   |   |    |
| T83                                | Formed PCB 8.8 × 0.5 × Surface mount  |              |    |    |    |   |   |    |
| T84                                | Short PCB 0.8 × 0.5 × 2.0 long  |              |    |    |    |   |   |    |
| T85                                | Long PCB 0.8 × 0.5 × 6.85 long  |              |    |    |    |   |   |    |
| T86                                | PCB 0.8 × 0.5 × 4.0 long (equi-spaced)  |              |    |    |    |   |   |    |
| T11                                | Solder 2.95 × 0.5 × 3.6 long  |              |    |    |    |   |   |    |
| Circuit                            | No symbol, change-over  |              |    |    |    |   |   |    |
| C2                                 | Normally closed   |              |    |    |    |   |   |    |
| C4                                 | Normally open   |              |    |    |    |   |   |    |
| Actuators                          | No symbol, without lever  |              |    |    |    |   |   |    |
| Y1                                 | Plain lever 18.0 mm   |              |    |    |    |   |   |    |
| Y2                                 | Plain lever 25.0 mm   |              |    |    |    |   |   |    |
| Y3                                 | Plain lever 32.0 mm   |              |    |    |    |   |   |    |
| YC                                 | Cam follower lever 18.5 mm  |              |    |    |    |   |   |    |
| YR                                 | Roller lever 16.0 mm  |              |    |    |    |   |   |    |
| PB                                 | Push Button (see specification PBA4/QA4)  |              |    |    |    |   |   |    |
| QA                                 | Push Button (see specification PBA4/QA4)  |              |    |    |    |   |   |    |
| Other actuators on special request |   |              |    |    |    |   |   |    |
| Actuator Position                  | No symbol, without lever, or lever fitted at the end nearest to the Plunger   |              |    |    |    |   |   |    |
| 0                                  | With lever fitted at end opposite to plunger  |              |    |    |    |   |   |    |
| Contact Material                   | No symbol, Fine silver  |              |    |    |    |   |   |    |
| G                                  | Gold plate on silver  |              |    |    |    |   |   |    |
| X                                  | Gold alloy on silver palladium crosspoint   |              |    |    |    |   |   |    |
| Approvals                          | No symbol, without approval   |              |    |    |    |   |   |    |
| UL                                 | UL, CSA and ENEC approval   |              |    |    |    |   |   |    |
| Special Features                   | / <input type="checkbox"/> <input type="checkbox"/> <input type="checkbox"/> <input type="checkbox"/> Saia specialise in customer specific solutions.<br>Additional product variants are available or can be provided.<br>If your requirements cannot be satisfied from the options listed,<br>please contact <a href="http://www.saia-burgess.com">www.saia-burgess.com</a> or your local SB outlet. |              |    |    |    |   |   |    |

# V4NC

## V4NC

- Characteristics
- wide variety of levers
  - peg mounting option
  - pre-wired option
  - sealed (IP6K7)
  - solder and faston terminals
  - PCB terminals

Rating 250 VAC, 5 A

Dimensions (mm) 20 × 10.3 × 6.4

- Actuator
- plunger
  - plain levers
  - roller levers
  - simulated roller levers

Approvals none



## Preferred Range

| Ordering Reference | Actuating Force |       | Sealing      | Operating pos. |       | Terminal     | Circuit | Actuator     | Contacts | Electrical rating |
|--------------------|-----------------|-------|--------------|----------------|-------|--------------|---------|--------------|----------|-------------------|
|                    | (N)             | (ozf) |              | (mm)           | (in)  |              |         |              |          |                   |
| V4NCT7             | 1,7             | 6,114 | No symbol    | 8,40           | 0,331 | Solder       | CO      | Plunger      | Ag       | 250 VAC, 5 A      |
| V4NCT7A1           | 0,8             | 2,877 | No symbol    | 10,85          | 0,427 | Solder       | CO      | Plain lever  | Ag       | 250 VAC, 5 A      |
| V4NCT7AR           | 0,8             | 2,877 | No symbol    | 16,00          | 0,630 | Solder       | CO      | Roller lever | Ag       | 250 VAC, 5 A      |
| V4NCS              | 2,5             | 8,992 | Sealed IP6K7 | 8,40           | 0,331 | Cable 500 mm | CO      | Plunger      | Ag       | 250 VAC, 5 A      |
| V4NCSA1            | 0,9             | 3,237 | Sealed IP6K7 | 10,80          | 0,425 | Cable 500 mm | CO      | Plain lever  | Ag       | 250 VAC, 5 A      |
| V4NCSAR            | 0,9             | 3,237 | Sealed IP6K7 | 15,90          | 0,626 | Cable 500 mm | CO      | Roller lever | Ag       | 250 VAC, 5 A      |

## Specifications

|                      |   |
|----------------------|---|
| Housing              | Glass fibre reinforced Polyamide (PA 6.6)   |
| Plunger              | Polyacetal POM/(PA 4.6)   |
| Mechanism            | Snap-action coil spring mechanism with stainless steel spring                               |
| Functions            | Change-over, normally closed or normally open   |
| Contacts             | Fine Silver, Gold plate on silver, Gold alloy on silver palladium (crosspoint)              |
| Terminals            | Gold flashed  |
| Temperature range °C | -40°C to +85°C/120°C  |
| Mechanical life      | 5 × 10 <sup>6</sup> cycles minimum (impact free actuation) for the cowl 3 × 10 <sup>6</sup> |
| Protection           | IP40, IP6K7 (depend on type), Flux-proof terminal entries (for all types)                   |
| Mounting             | Side mounting (moulded mounting pegs on request)  |
| Actuators            | Plain lever, cam follower, roller lever, simulated roller (cam follower) lever              |
| Accessories          | Lug mounting frame, clip-on terminals cover, insulating sheet                               |

### Circuit diagram

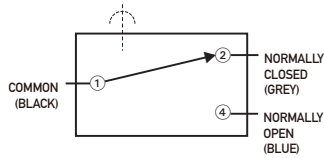

### Dimensions

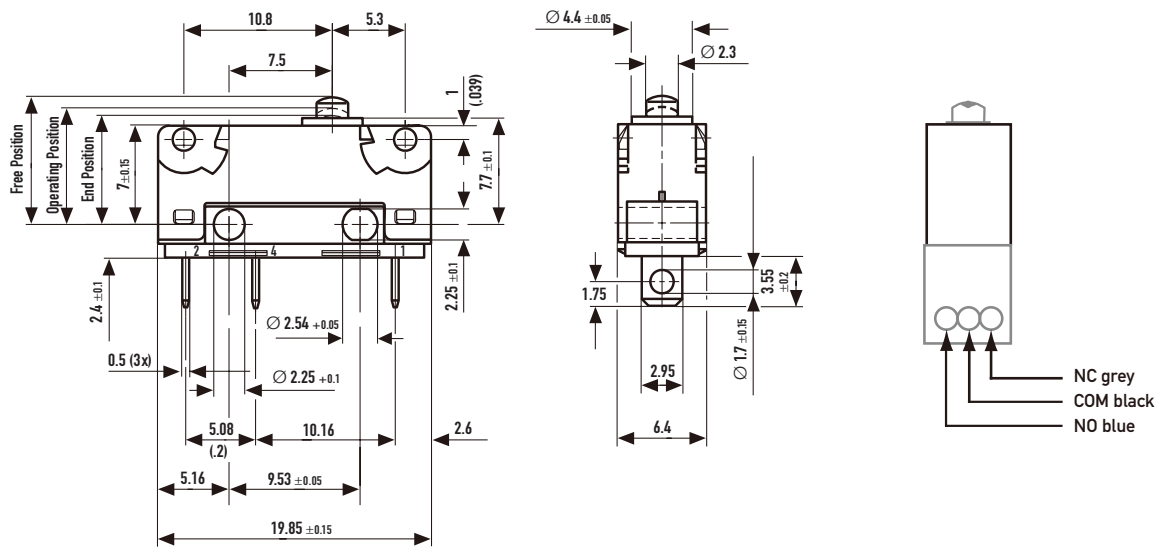

### Prewired version with cable box

For type coding key please contact Saia

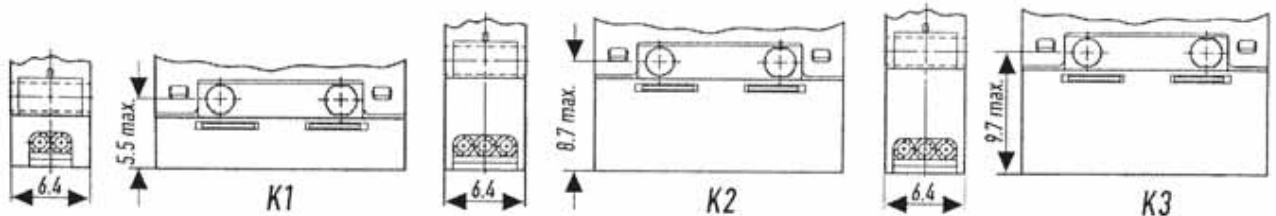

Standard cable FLRY 0.5 mm<sup>2</sup> with max. outside diameter 1.8 mm  
Standard cable box is K2

## Operating Characteristics

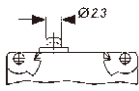
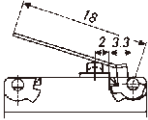
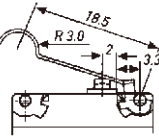
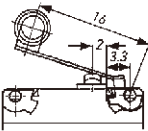
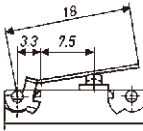
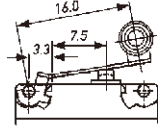
| Actuator   | Reference | Actuating Force |       | Release Force |       | Free Position |       | Operating Position |               | Movement Differential |       |
|--|-----------|-----------------|-------|---------------|-------|---------------|-------|--------------------|---------------|-----------------------|-------|
|  |           | Maximum (N)     | (ozf) | Minimum (N)   | (ozf) | Maximum (mm)  | (in)  | (mm)               | (in)          | Maximum (mm)          | (in)  |
| <br>Plunger     | V4NC..    | 1.7             | 6.114 | 0.3           | 1.079 | 9.2           | 0.362 | 8.4 ± 0.3          | 0.331 ± 0.012 | 0.1                   | 0.004 |
|  | V4NCE..   | 1.7             | 6.114 | 0.3           | 1.079 | 9.7           | 0.382 | 8.9 ± 0.3          | 0.35 ± 0.012  | 0.1                   | 0.004 |
|  | V4NCS..   | 2.5             | 8.992 | 0.5           | 1.798 | 9.2           | 0.362 | 8.4 ± 0.3          | 0.331 ± 0.012 | 0.1                   | 0.004 |
|  | V4NCSE..  | 2.5             | 8.992 | 0.5           | 1.798 | 9.7           | 0.382 | 8.9 ± 0.3          | 0.35 ± 0.012  | 0.1                   | 0.004 |
| <br>A1 Lever    | V4NC..    | 0.8             | 2.877 | 0.07          | 0.251 | 13.4          | 0.527 | 10.85 ± 1.3        | 0.427 ± 0.051 | 0.4                   | 0.016 |
|  | V4NCE..   | 0.8             | 2.877 | 0.07          | 0.251 | 14.8          | 0.582 | 12.4 ± 1.3         | 0.488 ± 0.051 | 0.4                   | 0.016 |
|  | V4NCS..   | 0.9             | 3.237 | 0.1           | 0.359 | 13.4          | 0.527 | 10.8 ± 1.3         | 0.425 ± 0.051 | 0.4                   | 0.016 |
|  | V4NCSE..  | 0.9             | 3.237 | 0.1           | 0.359 | 14.8          | 0.582 | 12.4 ± 1.3         | 0.488 ± 0.051 | 0.4                   | 0.016 |
| Width of lever 4.0mm/0.16 in   |           |                 |       |               |       |               |       |                    |               |                       |       |
| <br>AC Lever    | V4NC..    | 0.8             | 2.877 | 0.07          | 0.251 | 16.1          | 0.634 | 13.5 ± 1.3         | 0.531 ± 0.051 | 0.4                   | 0.016 |
|  | V4NCE..   | 0.8             | 2.877 | 0.07          | 0.251 | 17.6          | 0.693 | 15.1 ± 1.3         | 0.594 ± 0.051 | 0.4                   | 0.016 |
|  | V4NCS..   | 0.9             | 3.237 | 0.1           | 0.359 | 16.1          | 0.634 | 13.4 ± 1.3         | 0.527 ± 0.051 | 0.4                   | 0.016 |
|  | V4NCSE..  | 0.9             | 3.237 | 0.1           | 0.359 | 17.6          | 0.693 | 15.1 ± 1.3         | 0.594 ± 0.051 | 0.4                   | 0.016 |
| Width of lever 4.0mm/0.16 in   |           |                 |       |               |       |               |       |                    |               |                       |       |
| <br>AR Lever   | V4NC..    | 0.8             | 2.877 | 0.07          | 0.251 | 18.1          | 0.712 | 16 ± 1.2           | 0.63 ± 0.047  | 0.4                   | 0.016 |
|  | V4NCE..   | 0.8             | 2.877 | 0.07          | 0.251 | 19.2          | 0.756 | 17.3 ± 1.2         | 0.681 ± 0.047 | 0.4                   | 0.016 |
|  | V4NCS..   | 0.9             | 3.237 | 0.1           | 0.359 | 18.1          | 0.712 | 15.9 ± 1.2         | 0.626 ± 0.047 | 0.4                   | 0.016 |
|  | V4NCSE..  | 0.9             | 3.237 | 0.1           | 0.359 | 19.2          | 0.756 | 17.3 ± 1.2         | 0.681 ± 0.047 | 0.4                   | 0.016 |
| Width of lever 4.0mm/0.16 in   |           |                 |       |               |       |               |       |                    |               |                       |       |
| <br>A10 Lever | V4NC..    | 1.3             | 4.676 | 0.13          | 0.467 | 10.7          | 0.421 | 9.4 ± 0.7          | 0.37 ± 0.027  | 0.2                   | 0.008 |
|  | V4NCE..   | 1.3             | 4.676 | 0.13          | 0.467 | 11.5          | 0.453 | 10.2 ± 0.7         | 0.401 ± 0.027 | 0.2                   | 0.008 |
|  | V4NCS..   | 1.8             | 6.474 | 0.2           | 0.719 | 10.7          | 0.421 | 9.3 ± 0.7          | 0.366 ± 0.027 | 0.2                   | 0.008 |
|  | V4NCSE..  | 1.8             | 6.474 | 0.2           | 0.719 | 11.5          | 0.453 | 10.1 ± 0.7         | 0.397 ± 0.027 | 0.2                   | 0.008 |
| Width of lever 4.0mm/0.16 in   |           |                 |       |               |       |               |       |                    |               |                       |       |
| <br>ARO Lever | V4NC..    | 1.3             | 4.676 | 0.13          | 0.467 | 15.8          | 0.622 | 14.7 ± 0.6         | 0.579 ± 0.023 | 0.2                   | 0.008 |
|  | V4NCE..   | 1.3             | 4.676 | 0.13          | 0.467 | 16.5          | 0.649 | 15.4 ± 0.6         | 0.606 ± 0.023 | 0.2                   | 0.008 |
|  | V4NCS..   | 1.8             | 6.474 | 0.2           | 0.719 | 15.8          | 0.622 | 14.7 ± 0.6         | 0.579 ± 0.023 | 0.2                   | 0.008 |
|  | V4NCSE..  | 1.8             | 6.474 | 0.2           | 0.719 | 16.5          | 0.649 | 15.4 ± 0.6         | 0.606 ± 0.023 | 0.2                   | 0.008 |
| Width of lever 4.0mm/0.16 in   |           |                 |       |               |       |               |       |                    |               |                       |       |

Operating characteristics shown above are specified from mounting hole centres.

Over travel: Flush with case. (7.8 mm min) The case should not be used as an end stop.

## Ordering Reference

|                   |   |  |   |    |    |    |   |   |
|-------------------|---|--|---|----|----|----|---|---|
| Basic type        | V4NC  | Example: V4NC  | E | T7 | C2 | A1 | 0 | G |
| Actuating Force   | No symbol, standard force   |  |   |    |    |    |   |   |
| Type of sealing   | No symbol, unsealed, standard travel  |  |   |    |    |    |   |   |
|                   | E   | Unsealed with extended overtravel (0.5 mm)   |   |    |    |    |   |   |
|                   | S   | Sealed IP6K7 standard travel   |   |    |    |    |   |   |
|                   | B   | Sealed IP6K7 with extended overtravel (0.5 mm)   |   |    |    |    |   |   |
| Terminals         | No symbol, pre-wired 500 mm with cable box (V4NCS/B only)   |  |   |    |    |    |   |   |
|                   | T7  | Solder 2.95 × 0.5 × 3.55 long  |   |    |    |    |   |   |
|                   | T8  | PCB 0.8 × 0.5 × 4.0 long   |   |    |    |    |   |   |
|                   | T9  | Faston 2.8 × 0.5 × 9.5 long  |   |    |    |    |   |   |
|                   | T81   | Formed PCB 0.8 × 0.5 × 3.8 long  |   |    |    |    |   |   |
|                   | T82   | Formed PCB 0.8 × 0.5 × 3.8 long  |   |    |    |    |   |   |
|                   | T84   | Short PCB 0.8 × 0.5 × 2.0 long   |   |    |    |    |   |   |
|                   | T85   | Long PCB 0.8 × 0.5 × 6.85 long   |   |    |    |    |   |   |
|                   | T11   | Welding/solder 2.95 × 0.5 × 3.55 long  |   |    |    |    |   |   |
| Circuit           | No symbol, change-over  |  |   |    |    |    |   |   |
|                   | C2  | Normally closed  |   |    |    |    |   |   |
|                   | C4  | Normally open  |   |    |    |    |   |   |
| Actuators         | No symbol, without lever  |  |   |    |    |    |   |   |
|                   | A1  | Plain lever 18.0 mm  |   |    |    |    |   |   |
|                   | A2  | Plain lever 25.0 mm  |   |    |    |    |   |   |
|                   | A3  | Plain lever 32.0 mm  |   |    |    |    |   |   |
|                   | A7  | Plain lever 60.0 mm  |   |    |    |    |   |   |
|                   | AC  | Cam follower lever 18.5 mm (AC1)   |   |    |    |    |   |   |
|                   | AR  | Roller lever 16.0 mm (AR1)   |   |    |    |    |   |   |
|                   | AP  | Roller lever 17.9 mm (AR2)   |   |    |    |    |   |   |
|                   | PB  | Push Button (see specification PBA4/QA4)   |   |    |    |    |   |   |
|                   | QA  | Push Button (see specification PBA4/QA4)   |   |    |    |    |   |   |
|                   | Other actuators on special request  |  |   |    |    |    |   |   |
| Actuator Position | No symbol, without lever, or lever fitted at the end nearest to the Plunger                           |  |   |    |    |    |   |   |
|                   | 0   | With lever fitted at end opposite to plunger   |   |    |    |    |   |   |
| Contact Material  | No symbol, Ag   |  |   |    |    |    |   |   |
|                   | G   | Gold plate on silver (GP)  |   |    |    |    |   |   |
|                   | X   | Gold alloy on silver palladium crosspoint (AUX)  |   |    |    |    |   |   |
|                   | Other contact materials on special request  |  |   |    |    |    |   |   |
| Special Features  | / <input type="checkbox"/> <input type="checkbox"/> <input type="checkbox"/> <input type="checkbox"/> | Saia specialise in customer specific solutions. Additional product variants are available or can be provided. If your requirements cannot be satisfied from the options listed, please contact <a href="http://www.saia-burgess.com">www.saia-burgess.com</a> or your local SB outlet. |   |    |    |    |   |   |



# Thermoset plastic Microswitches



Circuit diagram

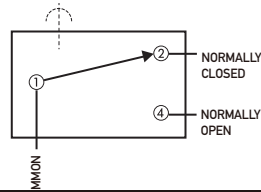

Dimension

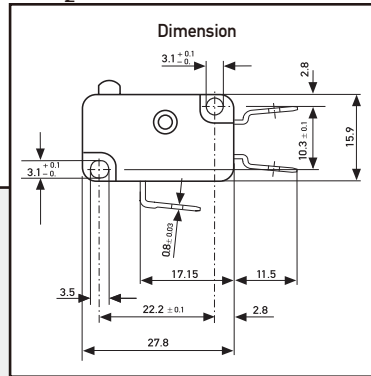

## XG

- Characteristics
- wide range of forces and ratings
  - long mechanical and electrical life
  - solder, faston and PCB terminals
  - compliant to IEC 60335-1, 4. ed.

Rating 250 VAC, 26 A max.

Dimensions (mm) 27.8 × 15.9 × 10.3

- Actuator
- plunger
  - plain levers
  - roller levers
  - simulated roller levers

Approvals ENEC, UL, cUL, CSA



## Preferred Range

| Ordering Reference | Actuating Force |       | Operating pos. |      | Terminal | Circuit | Actuator     | Contacts    | Electrical rating |        |
|--------------------|-----------------|-------|----------------|------|----------|---------|--------------|-------------|-------------------|--------|
|                    | (N)             | (ozf) | (mm)           | (in) |          |         |              |             | ENEC              | UL/CSA |
| XGG2-88Z1          | 3.20            | 11.43 | 14.7           | 0.57 | Faston   | CO      | Plunger      | Ag / AgNi10 | 16(6) A           | 15 A   |
| XGG2-88-J23Z1      | 1.40            | 5.03  | 14.9           | 0.59 | Faston   | CO      | Plain lever  | Ag / AgNi10 | 16(6) A           | 15 A   |
| XGG2-88-J26Z1      | 0.91            | 3.27  | 14.5           | 0.57 | Faston   | CO      | Plain lever  | Ag / AgNi10 | 16(6) A           | 15 A   |
| XGG2-88-J27Z1      | 0.65            | 2.34  | 13.7           | 0.54 | Faston   | CO      | Plain lever  | Ag / AgNi10 | 16(6) A           | 15 A   |
| XGG2-88-S20Z1      | 3.20            | 11.43 | 20.2           | 0.79 | Faston   | CO      | Roller lever | Ag / AgNi10 | 16(6) A           | 15 A   |
| XGG2-88-S21Z1      | 1.55            | 5.57  | 20.1           | 0.79 | Faston   | CO      | Roller lever | Ag / AgNi10 | 16(6) A           | 15 A   |
| XGG3-88Z1          | 3.20            | 11.43 | 14.7           | 0.57 | Solder   | CO      | Plunger      | Ag / AgNi10 | 16(6) A           | 15 A   |
| XGG6-88Z1          | 3.20            | 11.43 | 14.7           | 0.57 | Faston   | CO      | Plunger      | Ag / AgNi10 | 16(6) A           | 15 A   |
| XGC2-88Z1          | 0.80            | 2.86  | 14.7           | 0.57 | Faston   | CO      | Plunger      | Ag / AgNi10 | 12(6) A           | 10 A   |
| XGC2-88-J23Z1      | 0.35            | 1.26  | 15.0           | 0.59 | Faston   | CO      | Plain lever  | Ag / AgNi10 | 12(6) A           | 10 A   |
| XGC2-88-S20Z1      | 0.80            | 2.86  | 20.2           | 0.79 | Faston   | CO      | Roller lever | Ag / AgNi10 | 12(6) A           | 10 A   |
| XGC6-88Z1          | 0.80            | 2.86  | 14.7           | 0.57 | Faston   | CO      | Plunger      | Ag / AgNi10 | 12(6) A           | 10 A   |
| XGK2-88Z1          | 1.50            | 5.36  | 14.7           | 0.57 | Faston   | CO      | Plunger      | Ag / AgNi10 | 12(6) A           | 12 A   |
| XGK2-88-J26Z1      | 0.43            | 1.55  | 14.7           | 0.57 | Faston   | CO      | Plain lever  | Ag / AgNi10 | 12(6) A           | 12 A   |
| XGK2-88-S21Z1      | 0.71            | 2.55  | 20.2           | 0.80 | Faston   | CO      | Roller lever | Ag / AgNi10 | 12(6) A           | 12 A   |
| XGK3-88Z1          | 1.50            | 5.36  | 14.7           | 0.57 | Solder   | CO      | Plunger      | Ag / AgNi10 | 12(6) A           | 12 A   |
| XGK6-88Z1          | 1.50            | 5.36  | 14.7           | 0.57 | Faston   | CO      | Plunger      | Ag / AgNi10 | 12(6) A           | 12 A   |
| XG02-88Z1          | 1.20            | 4.29  | 14.5           | 0.57 | Faston   | CO      | Plunger      | Ag / AgNi10 | 16(6) A           | 15 A   |
| XG02-88-J27Z1      | 0.25            | 0.90  | 13.6           | 0.54 | Faston   | CO      | Plain lever  | Ag / AgNi10 | 16(6) A           | 15 A   |
| XG02-88-S20Z1      | 1.20            | 4.29  | 20.1           | 0.79 | Faston   | CO      | Roller lever | Ag / AgNi10 | 16(6) A           | 15 A   |
| XG06-88Z1          | 1.20            | 4.29  | 14.5           | 0.57 | Faston   | CO      | Plunger      | Ag / AgNi10 | 16(6) A           | 15 A   |

## Specifications

|                      |  |
|----------------------|--|
| Housing              | Melamine-Formaldehyd. Thermosetting  |
| Plunger              | POM, PPS, MF depending on temperature /type  |
| Mechanism            | Snap-action, single pole beryllium bronze blade mechanisme with wiping contacts  |
| Functions            | Change-over, normally-closed (except XGG and XGK) or normally-open   |
| Contacts             | Fine silver (Ag), silver nickel (AgNi10), gold-plated (Au), silver cadmium oxide (AgCdO)   |
| Terminals            | Solder, faston, screw, PCB and side mounting PCB terminals. RAST 5 terminals (5.0 mm pitch)  |
| Temperature range °C | -40° C to +150° C  |
| Mechanical life      | 2,5 · 10 <sup>5</sup> cycles minimum, 50 · 10 <sup>4</sup> cycles maximum<br>(Actuation: sinusoidal and maximum up to 80% of the overtravel) |
| Protection           | Enclosure IP40   |
| Mounting             | Side mounting via mounting holes   |
| Actuators            | Stainless steel  |

Circuit diagram

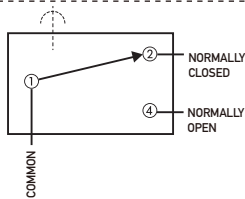

Actuating force/travel

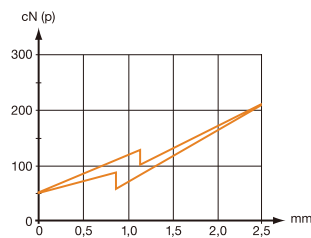

Contact force/travel

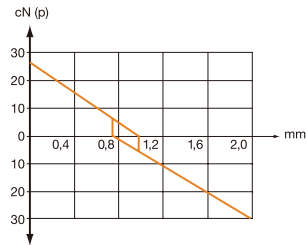

Dimensions

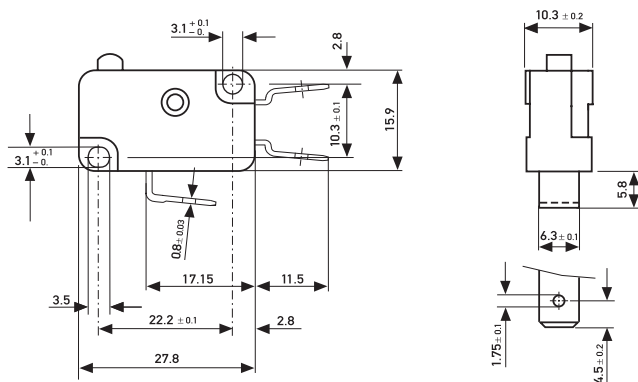

Maximum DC rating

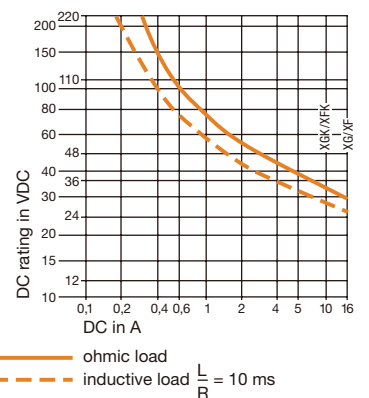

## Recommended maximum electrical ratings

|          | Voltage (VAC) | Approvals ENEC | UL   | (VAC)   |           | Voltage (VAC) | Approvals ENEC | UL  | (VAC)   |
|----------|---------------|----------------|------|---------|-----------|---------------|----------------|-----|---------|
| XGG..-88 | 250           | 16 (6) 5E4     | 15 A | 125/250 | XGT..-86  | 250           | 26 (10) 25E3   | 25A | 125/250 |
| XGA..-88 | 250           | 16 (6) 5E4     | 15 A | 125/250 | XGD..-86  | 250           | 22 (6) 5E4     | 21A | 125/250 |
| XGM..-88 | 250           | 16 (6) 5E4     | 15 A | 125/250 | XGA...-86 | 250           | 20 (8) 5E4     | 15A | 125/250 |
| XGO..-88 | 250           | 16 (6) 5E4     | 15 A | 125/250 | XGM...-86 | 250           | 20 (8) 5E4     | 15A | 125/250 |
| XGB..-88 | 250           | 12 (6) 5E4     | 12 A | 125/250 | XGO...-86 | 250           | 20 (8) 5E4     | 15A | 125/250 |
| XGC..-88 | 250           | 12 (6) 5E4     | 10 A | 125/250 | XGA...-86 | 400           | 10 (6) 5E4     | -   | -       |
| XGH..-88 | 250           | 12 (6) 5E4     | 10 A | 125/250 | XGG...-86 | 400           | 10 (6) 5E4     | -   | -       |
| XGK..-88 | 250           | 12 (6) 5E4     | 12 A | 125/250 | XGM...-86 | 400           | 10 (6) 5E4     | -   | -       |
| XG...-88 | 400           | 3 (2) 5E4      |      |         | XGO...-86 | 400           | 10 (6) 5E4     | -   | -       |

## Operating Characteristics

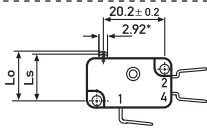
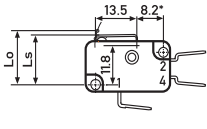
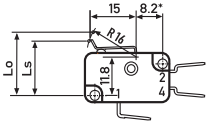
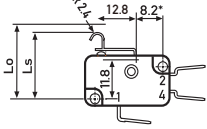
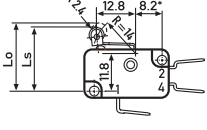
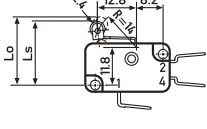
| Actuator   | Reference  | Actuating Force Maximum |       | Release Force Minimum |       | Free Position Maximum |      | Operating Position |              | Movement Differential Maximum |       | Total travelled position |       |       |
|--|--|-------------------------|-------|-----------------------|-------|-----------------------|------|--------------------|--------------|-------------------------------|-------|--------------------------|-------|-------|
|  |  | (N)                     | (ozf) | (N)                   | (ozf) | (mm)                  | (in) | (mm)               | (in)         | (mm)                          | (in)  | (mm)                     | (in)  |       |
|    | XGG..  | 3.2                     | 11.43 | 0.4                   | 1.43  | 15.75                 | 0.62 | 14.7               | 0.57         | 0.35                          | 0.013 | 13.2                     | 0.519 |       |
|  | XGA..  | 3.2                     | 11.43 | 0.6                   | 2.14  | 15.75                 | 0.62 | 14.7               | 0.57         | 0.15                          | 0.006 | 13.2                     | 0.519 |       |
|  | XGM..  | 2                       | 7.14  | 0.5                   | 1.79  | 15.6                  | 0.61 | 14.5               | 0.57         | 0.35                          | 0.013 | 13.7                     | 0.539 |       |
|  | XGO..  | 1.2                     | 4.29  | 0.1                   | 0.36  | 15.6                  | 0.61 | 14.5               | 0.57         | 0.35                          | 0.013 | 13.7                     | 0.539 |       |
|  | XGK..  | 1.5                     | 5.36  | 0.2                   | 0.71  | 15.75                 | 0.62 | 14.7               | +0.2 0.57    | 0.35                          | 0.013 | 13.2                     | 0.519 |       |
|  | XGB..  | 1.5                     | 5.36  | 0.3                   | 1.07  | 15.75                 | 0.62 | 14.7               | -0.4 0.57    | +0.007 -0.015                 | 0.15  | 0.006                    | 13.2  | 0.519 |
|  | XGC..  | 0.8                     | 2.86  | 0.1                   | 0.36  | 15.75                 | 0.62 | 14.7               | 0.57         | 0.15                          | 0.006 | 13.2                     | 0.519 |       |
|  | XGH..  | 0.45                    | 1.61  | 0.05                  | 0.18  | 15.6                  | 0.61 | 14.5               | 0.57         | 0.35                          | 0.013 | 13.7                     | 0.539 |       |
|  | XGT..  | 3.2                     | 11.43 | 0.6                   | 2.14  | 15.75                 | 0.62 | 14.7               | 0.57         | 0.15                          | 0.006 | 13.2                     | 0.519 |       |
|  | XGD..  | 1.7                     | 6.07  | 0.15                  | 0.54  | 15.75                 | 0.62 | 14.7               | 0.57         | 0.15                          | 0.006 | 13.2                     | 0.519 |       |
|    | XGG..  | 3.2                     | 11.43 | 0.36                  | 1.29  | 16.5                  | 0.64 | 15.1 ± 0.5         | 0.59 ± 0.019 | 0.4                           | 0.015 | 14                       | 0.551 |       |
|  | XGA..  | 3.2                     | 11.43 | 0.54                  | 1.93  | 16.5                  | 0.64 | 15.1 ± 0.5         | 0.59 ± 0.019 | 0.2                           | 0.007 | 14                       | 0.551 |       |
|  | XGM..  | 2                       | 7.14  | 0.45                  | 1.61  | 16.5                  | 0.64 | 15 ± 0.5           | 0.59 ± 0.019 | 0.4                           | 0.015 | 14.4                     | 0.566 |       |
|  | XGO..  | 1.2                     | 4.29  | 0.09                  | 0.34  | 16.5                  | 0.64 | 15 ± 0.5           | 0.59 ± 0.019 | 0.4                           | 0.015 | 14.4                     | 0.566 |       |
|  | XGK..  | 1.5                     | 5.36  | 0.18                  | 0.64  | 16.5                  | 0.64 | 15.1 ± 0.5         | 0.59 ± 0.019 | 0.4                           | 0.015 | 14                       | 0.551 |       |
|  | XGB..  | 1.5                     | 5.36  | 0.27                  | 0.96  | 16.5                  | 0.64 | 15.1 ± 0.5         | 0.59 ± 0.019 | 0.2                           | 0.007 | 14                       | 0.551 |       |
|  | XGC..  | 0.8                     | 2.86  | 0.09                  | 0.32  | 16.5                  | 0.64 | 15.1 ± 0.5         | 0.59 ± 0.019 | 0.2                           | 0.007 | 14                       | 0.551 |       |
|  | XGH..  | 0.45                    | 1.61  | 0.04                  | 0.14  | 16.5                  | 0.64 | 15 ± 0.5           | 0.59 ± 0.019 | 0.4                           | 0.015 | 14.4                     | 0.566 |       |
|  | Width of lever 7 mm / 0.28 in – also available with width 4 mm / 0.16 in                 |                         |       |                       |       |                       |      |                    |              |                               |       |                          |       |       |
|  |   | XGG..                   | 2.6   | 9.29                  | 0.32  | 1.14                  | 19.2 | 0.75               | 17.5 ± 0.7   | 0.68 ± 0.027                  | 0.45  | 0.017                    | 16.4  | 0.645 |
| XGA..  |  | 2.6                     | 9.29  | 0.48                  | 1.71  | 19.2                  | 0.75 | 17.5 ± 0.7         | 0.68 ± 0.027 | 0.2                           | 0.007 | 16.4                     | 0.645 |       |
| XGM..  |  | 1.65                    | 5.89  | 0.4                   | 1.43  | 19.2                  | 0.75 | 17.3 ± 0.7         | 0.68 ± 0.027 | 0.45                          | 0.017 | 16.9                     | 0.665 |       |
| XGO..  |  | 1                       | 3.57  | 0.08                  | 0.29  | 19.2                  | 0.75 | 17.3 ± 0.7         | 0.68 ± 0.027 | 0.45                          | 0.017 | 16.9                     | 0.665 |       |
| XGK..  |  | 1.25                    | 4.46  | 0.16                  | 0.57  | 19.2                  | 0.75 | 17.5 ± 0.7         | 0.68 ± 0.027 | 0.45                          | 0.017 | 16.4                     | 0.645 |       |
| XGB..  |  | 1.25                    | 4.46  | 0.24                  | 0.86  | 19.2                  | 0.75 | 17.5 ± 0.7         | 0.68 ± 0.027 | 0.2                           | 0.007 | 16.4                     | 0.645 |       |
| XGC..  |  | 0.65                    | 2.32  | 0.08                  | 1.29  | 19.2                  | 0.75 | 17.5 ± 0.7         | 0.68 ± 0.027 | 0.2                           | 0.007 | 16.4                     | 0.645 |       |
| XGH..  |  | 1.37                    | 1.32  | 0.04                  | 0.14  | 19.2                  | 0.75 | 17.3 ± 0.7         | 0.68 ± 0.027 | 0.45                          | 0.017 | 16.9                     | 0.665 |       |
| Width of lever 7 mm / 0.28 in  |  |                         |       |                       |       |                       |      |                    |              |                               |       |                          |       |       |
|  |  | XGG..                   | 3.2   | 11.43                 | 0.38  | 1.36                  | 21.8 | 0.85               | 20.5 ± 0.6   | 0.81 ± 0.023                  | 0.4   | 0.015                    | 19.5  | 0.767 |
|  | XGA..  | 3.2                     | 11.43 | 0.85                  | 3.04  | 21.8                  | 0.85 | 20.5 ± 0.6         | 0.81 ± 0.023 | 0.2                           | 0.007 | 19.5                     | 0.767 |       |
|  | XGM..  | 2                       | 7.14  | 0.48                  | 1.71  | 21.8                  | 0.85 | 20.3 ± 0.6         | 0.8 ± 0.023  | 0.4                           | 0.015 | 19.8                     | 0.779 |       |
|  | XGO..  | 1.2                     | 4.29  | 0.09                  | 0.32  | 21.8                  | 0.85 | 20.1 ± 0.6         | 0.79 ± 0.023 | 0.4                           | 0.015 | 19.8                     | 0.779 |       |
|  | XGK..  | 1.5                     | 5.36  | 0.19                  | 0.68  | 21.8                  | 0.85 | 20.5 ± 0.6         | 0.81 ± 0.023 | 0.4                           | 0.015 | 19.5                     | 0.767 |       |
|  | XGB..  | 1.5                     | 5.36  | 0.29                  | 1.04  | 21.8                  | 0.85 | 20.5 ± 0.6         | 0.81 ± 0.023 | 0.2                           | 0.007 | 19.5                     | 0.767 |       |
|  | XGC..  | 0.8                     | 2.86  | 0.09                  | 0.32  | 21.8                  | 0.85 | 20.5 ± 0.6         | 0.81 ± 0.023 | 0.2                           | 0.007 | 19.5                     | 0.767 |       |
|  | XGH..  | 0.45                    | 1.61  | 0.04                  | 0.14  | 21.8                  | 0.85 | 20.3 ± 0.6         | 0.8 ± 0.023  | 0.4                           | 0.015 | 19.8                     | 0.779 |       |
|  | Width of lever 7 mm / 0.28 in  |                         |       |                       |       |                       |      |                    |              |                               |       |                          |       |       |
|  |  | XGG..                   | 3.2   | 11.43                 | 0.37  | 1.32                  | 21.8 | 0.85               | 20.2 ± 0.7   | 0.79 ± 0.027                  | 0.4   | 0.015                    | 19.3  | 0.759 |
| XGA..  |  | 3.2                     | 11.43 | 0.56                  | 2     | 21.8                  | 0.85 | 20.2 ± 0.7         | 0.79 ± 0.027 | 0.2                           | 0.007 | 19.3                     | 0.759 |       |
| XGM..  |  | 2                       | 7.14  | 0.47                  | 1.68  | 21.8                  | 0.85 | 20.1 ± 0.7         | 0.79 ± 0.027 | 0.4                           | 0.015 | 19.7                     | 0.775 |       |
| XGO..  |  | 1.2                     | 4.29  | 0.09                  | 0.32  | 21.8                  | 0.85 | 20.1 ± 0.7         | 0.79 ± 0.027 | 0.4                           | 0.015 | 19.7                     | 0.775 |       |
| XGK..  |  | 1.5                     | 5.36  | 0.18                  | 0.64  | 21.8                  | 0.85 | 20.2 ± 0.7         | 0.79 ± 0.027 | 0.4                           | 0.015 | 19.3                     | 0.759 |       |
| XGB..  |  | 1.5                     | 5.36  | 0.28                  | 1     | 21.8                  | 0.85 | 20.2 ± 0.7         | 0.79 ± 0.027 | 0.2                           | 0.007 | 19.3                     | 0.759 |       |
| XGC..  |  | 0.8                     | 2.86  | 0.09                  | 0.32  | 21.8                  | 0.85 | 20.2 ± 0.7         | 0.79 ± 0.027 | 0.2                           | 0.007 | 19.3                     | 0.759 |       |
| XGH..  |  | 0.45                    | 1.61  | 0.04                  | 0.14  | 21.8                  | 0.85 | 20.1 ± 0.7         | 0.79 ± 0.027 | 0.4                           | 0.015 | 19.7                     | 0.775 |       |
| Width of roller 6.6 mm / 0.26 in   |  |                         |       |                       |       |                       |      |                    |              |                               |       |                          |       |       |
|  |  | XGG..                   | 3.2   | 11.43                 | 0.37  | 1.32                  | 21.8 | 0.85               | 20.2 ± 0.7   | 0.79 ± 0.027                  | 0.4   | 0.015                    | 19.3  | 0.759 |
|  | XGA..  | 3.2                     | 11.43 | 0.56                  | 2     | 21.8                  | 0.85 | 20.2 ± 0.7         | 0.79 ± 0.027 | 0.2                           | 0.007 | 19.3                     | 0.759 |       |
|  | XGM..  | 2                       | 7.14  | 0.05                  | 1.68  | 21.8                  | 0.85 | 20.1 ± 0.7         | 0.79 ± 0.027 | 0.4                           | 0.015 | 19.7                     | 0.775 |       |
|  | XGO..  | 1.2                     | 4.29  | 0.09                  | 0.32  | 21.8                  | 0.85 | 20.1 ± 0.7         | 0.79 ± 0.027 | 0.4                           | 0.015 | 19.7                     | 0.775 |       |
|  | XGK..  | 1.5                     | 5.36  | 0.18                  | 0.64  | 21.8                  | 0.85 | 20.2 ± 0.7         | 0.79 ± 0.027 | 0.4                           | 0.015 | 19.3                     | 0.759 |       |
|  | XGB..  | 1.5                     | 5.36  | 0.28                  | 1     | 21.8                  | 0.85 | 20.2 ± 0.7         | 0.79 ± 0.027 | 0.2                           | 0.007 | 19.3                     | 0.759 |       |
|  | XGC..  | 0.8                     | 2.86  | 0.09                  | 0.32  | 21.8                  | 0.85 | 20.2 ± 0.7         | 0.79 ± 0.027 | 0.2                           | 0.007 | 19.3                     | 0.759 |       |
|  | XGH..  | 0.45                    | 1.61  | 0.04                  | 0.14  | 21.8                  | 0.85 | 20.1 ± 0.7         | 0.79 ± 0.027 | 0.4                           | 0.015 | 19.7                     | 0.775 |       |
|  | Width of roller 6.6 mm / 0.26 in   |                         |       |                       |       |                       |      |                    |              |                               |       |                          |       |       |

<sup>1)</sup> Lever distance 8.2 (0.32) for lever position –20, lever position (–J20, L20, S20, M20)  
Lever distance 14.0 (0.55) for lever position –40, lever position (–J40, L40, S40, M40)

\* For high temperature T125° C/T 150° C (ENEC, UL)

## Ordering Reference

|            |       |        |           |             |   |   |   |     |     |    |
|------------|-------|--------|-----------|-------------|---|---|---|-----|-----|----|
| Basic type | XGG.. | 3,2 N  | 11,43 ozf | Example: XG | 4 | 2 | A | -88 | J20 | Z1 |
|            | XGA.. | 3,2 N  | 11,43 ozf |             |   |   |   |     |     |    |
|            | XGM.. | 2,0 N  | 7,14 ozf  |             |   |   |   |     |     |    |
|            | XGO.. | 1,2 N  | 4,29 ozf  |             |   |   |   |     |     |    |
|            | XGK.. | 1,5 N  | 5,36 ozf  |             |   |   |   |     |     |    |
|            | XGB.. | 1,5 N  | 5,36 ozf  |             |   |   |   |     |     |    |
|            | XGC.. | 0,8 N  | 2,86 ozf  |             |   |   |   |     |     |    |
|            | XGH.. | 0,45 N | 1,61 ozf  |             |   |   |   |     |     |    |
|            | XGD.. | 1,7 N  | 6,07 ozf  |             |   |   |   |     |     |    |
|            | XGT.. | 3,2 N  | 11,43 ozf |             |   |   |   |     |     |    |

|         |                        |
|---------|------------------------|
| Circuit | No symbol, change-over |
| 4       | Normally closed (NC)   |
| 5       | Normally open (NO)     |

|           |    |                   |                   |
|-----------|----|-------------------|-------------------|
| Terminals | 2  | Faston            | 6,3 × 0,8         |
|           | 3  | Solder            | 1,7 × 3,2         |
|           | 4  | Faston            | 1 × 2,8 × 0,5 DIN |
|           | 5  | Faston            | 1 × 2,8 × 0,5     |
|           | 6  | Faston            | 4,8 × 0,5         |
|           | 7  | Screw             |                   |
|           | 8  | Faston            | 1 × 2,8 × 0,8 DIN |
|           | 9  | Faston            | 1 × 2,8 × 0,8     |
|           | 10 | Faston            | 4,8 × 0,8         |
|           | 11 | Faston            | 2 × 2,8 × 0,8     |
|           | 12 | Short solder      | ∅ 2,3             |
|           | 13 | Print bent (lid)  |                   |
|           | 14 | Print bent (base) |                   |
|           | 15 | Rast 5            | 6,3 × 0,8         |
|           | 19 | Short solder      | ∅ 1,7             |

Other types of terminals are available on request

| Version | ENEC           | UL   | Number of operations at rated load |         |
|---------|----------------|------|------------------------------------|---------|
|         |                |      | Europe                             | UL      |
|         | No symbol, T85 | T90  | 50.000                             | 6.000   |
| A       | T85            | T90  | 50.000                             | 100.000 |
| W       | T150           | T150 | 50.000                             | 6.000   |
| AW      | T150           | T150 | 50.000                             | 100.000 |
| B       | T85            | T90  | 10.000                             | 6.000   |
| V       | T125           | T130 | 50.000                             | 6.000   |
| AV      | T125           | T130 | 50.000                             | 100.000 |
| C       | T85            | T90  | 25.000                             | 6.000   |

|          |     |                             |
|----------|-----|-----------------------------|
| Contacts | -88 | Ag / AgNi10                 |
|          | -81 | Gold-plated 4 µm (Au) on Ag |
|          | -86 | Ag / Ag CdO                 |

|                   |                    |                             |         |
|-------------------|--------------------|-----------------------------|---------|
| Actuators         | No symbol, plunger |                             |         |
| J20 <sup>1)</sup> | J40 <sup>2)</sup>  | Plain lever                 | 13,5 mm |
| J22 <sup>1)</sup> | J42 <sup>2)</sup>  | Plain lever                 | 24,0 mm |
| J23 <sup>1)</sup> | J43 <sup>2)</sup>  | Plain lever                 | 27,8 mm |
| J27 <sup>1)</sup> | J47 <sup>2)</sup>  | Plain lever                 | 60,0 mm |
| M20 <sup>1)</sup> | M40 <sup>2)</sup>  | Plain lever formed          | 14,7 mm |
| L20 <sup>1)</sup> | L40 <sup>2)</sup>  | Cam follower                | 12,8 mm |
| L21 <sup>1)</sup> | L41 <sup>2)</sup>  | Cam follower                | 26,2 mm |
| S20 <sup>1)</sup> | S40 <sup>2)</sup>  | Roller lever                | 12,8 mm |
| T20 <sup>1)</sup> | T40 <sup>2)</sup>  | Roller lever, 150°C version | 12,8 mm |

Other actuators available on request

<sup>1)</sup> Lever distance 8.2 (0.32) for lever position –.20, lever position (-J20, L20, S20, M20)

<sup>2)</sup> Lever distance 14.0 (0.55) for lever position –.40, lever position (-J40, L40, S40, M40)

|           |                 |
|-----------|-----------------|
| Approvals | No symbol, ENEC |
| Z1        | UL, CSA         |

# Thermoplastic Microswitches



Circuit diagram

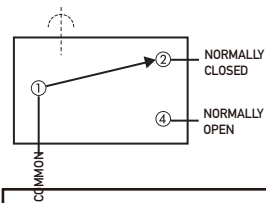

Dimension

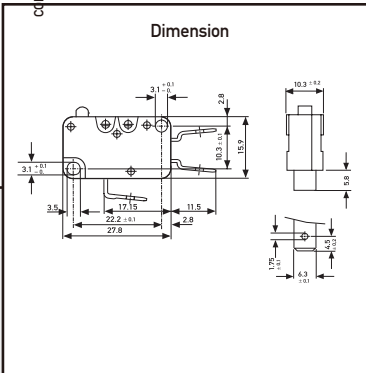

# X3

## X3

Characteristics ■ 8 mm creepage and clearance distance to the actuator  
 ■ long mechanical and electrical life  
 ■ solder, faston and PCB terminal

Rating 250 VAC, 21 A max.

Dimensions (mm) 27,8 × 15,9 × 10,3

Actuator ■ plunger  
 ■ straight lever  
 ■ simulated roller levers  
 ■ roller levers

Approvals UL, cUL, CSA, ENEC, CQC



## Preferred Range

| Ordering Reference | Actuating Force (N) | (ozf) | Operating pos. (mm) | Terminal | Circuit | Actuator     | Contacts  | Electrical rating ENEC | UL/CSA |
|--------------------|---------------------|-------|---------------------|----------|---------|--------------|-----------|------------------------|--------|
| X3M302K2KA         | 1,60                | 5,72  | 14,7 +0.2/-0.4      | Faston   | CO      | Plunger      | Ag/AgNi10 | 16 (6) A               | 20.5 A |
| X3M302K2KAJ32      | 0,88                | 3,15  | 15 ± 1,0            | Faston   | CO      | Plain lever  | Ag/AgNi10 | 16 (6) A               | 20.5 A |
| X3M302K2KAJ62      | 0,57                | 2,04  | 14,8 ± 1,5          | Faston   | CO      | Plain lever  | Ag/AgNi10 | 16 (6) A               | 20.5 A |
| X3M302K2KAT02      | 2,00                | 7,15  | 20,2 ± 0,7          | Faston   | CO      | Roller lever | Ag/AgNi10 | 16 (6) A               | 20.5 A |
| X3M303K2KA         | 1,60                | 5,72  | 14,7 +0.2/-0.4      | Solder   | CO      | Plunger      | Ag/AgNi10 | 16 (6) A               | 20.5 A |
| X3M306K2KA         | 1,60                | 5,72  | 14,7 +0.2/-0.4      | Faston   | CO      | Plunger      | Ag/AgNi10 | 16 (6) A               | 20.5 A |
| X3C302K2LB         | 0,80                | 2,86  | 14,7 +0.2/-0.4      | Faston   | CO      | Plunger      | Ag/AgNi10 | 10 (3) A               | 12 A   |
| X3C302K2LBJ32      | 0,35                | 1,25  | 15 ± 1,0            | Faston   | CO      | Plain lever  | Ag/AgNi10 | 10 (3) A               | 12 A   |
| X3C303K2LB         | 0,80                | 2,86  | 14,7 +0.2/-0.4      | Solder   | CO      | Plunger      | Ag/AgNi10 | 10 (3) A               | 12 A   |
| X3C306K2LB         | 0,80                | 2,86  | 14,7 +0.2/-0.4      | Faston   | CO      | Plunger      | Ag/AgNi10 | 10 (3) A               | 12 A   |
| X3L302K6DD         | 1,50                | 5,36  | 14,7 +0.2/-0.4      | Faston   | CO      | Plunger      | Ag/AgCdO  | 21 (8) A               | 21 A   |
| X3L303K6DD         | 1,50                | 5,36  | 14,7 +0.2/-0.4      | Solder   | CO      | Plunger      | Ag/AgCdO  | 21 (8) A               | 21 A   |

## Specifications

|                      |  |
|----------------------|--|
| Housing              | Thermoplastic  |
| Plunger              | Thermoplastic  |
| Mechanism            | Snap-action, single pole beryllium bronze blade mechanism with wiping contacts   |
| Contact carrier      | Brass  |
| Contacts             | Fine silver (Ag), silver nickel (AgNi10), gold-plated (Au), silver cadmium oxide (AgCd0)   |
| Terminals            | Solder, Faston and RAST 5 terminals  |
| Temperature range °C | Between -40°C and +125°C   |
| Mechanical life      | minimum cycles X3L: 10 <sup>5</sup> /X3M: 10 <sup>4</sup> /X3C: 2 · 10 <sup>6</sup><br>(Actuation: sinusoidal and maximum up to 80% of the overtravel) |
| Protection           | Enclosure IP40   |
| Mounting             | Side mounting via mounting holes   |
| Actuators            | Stainless steel (lever)  |

Circuit diagram

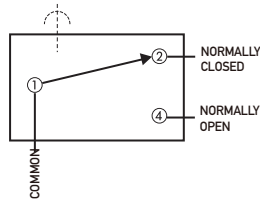

Actuating force/travel

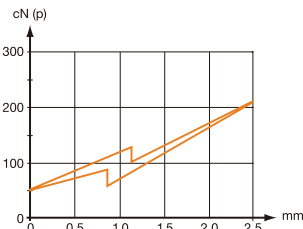

Contact force/travel

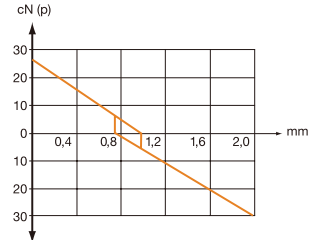

Dimensions

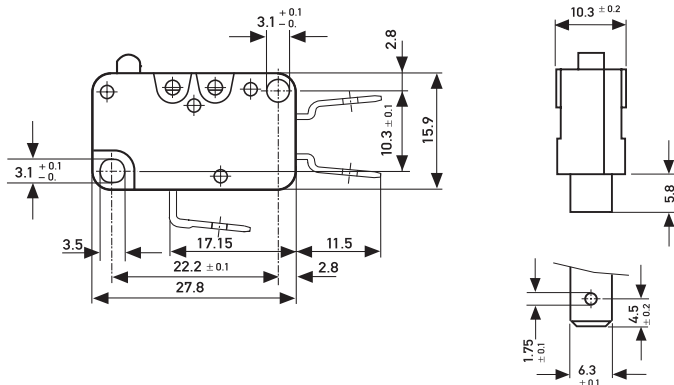

Maximum DC rating

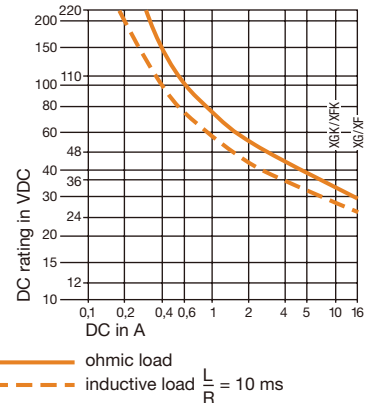

## Recommended maximum electrical ratings

|     | Voltage (VAC) | Resistive load (A) | Motor load (A) | Approvals ENEC (A) | Approvals ENEC (VAC) | Approvals UL (A) | Approvals UL (VAC) | Motor load |
|-----|---------------|--------------------|----------------|--------------------|----------------------|------------------|--------------------|------------|
| X3M | 250           | 16                 | 6              | 16 (6)             | 5E4                  | 20,5             | 250                | 1½ HP      |
| X3C | 250           | 10                 | 3              | 10 (3)             | 5E4                  | 12               | 250                | ½ HP       |
| X3L | 250           | 21                 | 8              | 21 (8)             | 1E4                  | 21               | 250                | 2 HP       |
|     |               |                    |                |                    |                      |                  | 125                | 1 HP       |

Current breaking capacities in the tables refer to Ag/AgNi10 contacts with the exception of X3L Ag/AgCd0

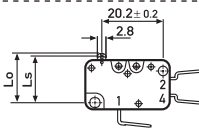
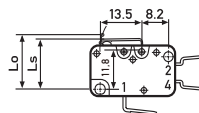
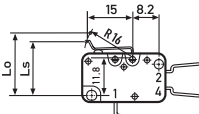
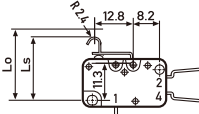
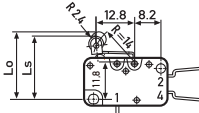

## Operating Characteristics

| Actuator   | Reference | Actuating Force Maximum |       | Release Force Minimum |       | Free Position Maximum |       | Operating Position |              | Movement Differential |        | Full overtravel position |       |      |      |
|--|-----------|-------------------------|-------|-----------------------|-------|-----------------------|-------|--------------------|--------------|-----------------------|--------|--------------------------|-------|------|------|
|  |           | (N)                     | (ozf) | (N)                   | (ozf) | (mm)                  | (in)  | (mm)               | (in)         | (mm)                  | (in)   | (mm)                     | (in)  |      |      |
| <br>Plunger     | X3C3      | 0.8                     | 2.877 | 0.05                  | 0.179 | 15.75                 | 0.62  | 14.7               | +0.2         | 0.578                 | +0.008 | 0.25                     | 0.009 | 13.2 | 0.52 |
|  | X3M3      | 1.6                     | 5.755 | 0.2                   | 0.719 | 15.75                 | 0.62  | 14.7               | -0.4         | 0.578                 | -0.006 | 0.25                     | 0.009 | 13.2 | 0.52 |
| <br>J02 Lever   | X3C3 ..   | 0.8                     | 2.877 | 0.045                 | 0.161 | 16.5                  | 0.649 | 15.1 ± 0.5         | 0.59 ± 0.02  | 0.35                  | 0.014  | 14                       | 0.55  |      |      |
|  | X3M3..    | 2                       | 7.193 | 0.18                  | 0.647 | 16.5                  | 0.649 | 15.1 ± 0.5         | 0.59 ± 0.02  | 0.35                  | 0.014  | 14                       | 0.55  |      |      |
| Width of lever 7.0 mm/0.28 in – also available with width 4 mm/0.16 in                           |           |                         |       |                       |       |                       |       |                    |              |                       |        |                          |       |      |      |
| <br>M02 Lever  | X3C3 ..   | 0.5                     | 1.798 | 0.04                  | 0.143 | 19.2                  | 0.755 | 17.5 ± 0.7         | 0.69 ± 0.028 | 0.35                  | 0.014  | 16.4                     | 0.65  |      |      |
|  | X3M3..    | 1.65                    | 5.934 | 0.16                  | 0.575 | 19.2                  | 0.755 | 17.5 ± 0.7         | 0.69 ± 0.028 | 0.35                  | 0.014  | 16.4                     | 0.65  |      |      |
| Width of lever 7.0 mm/0.28 in  |           |                         |       |                       |       |                       |       |                    |              |                       |        |                          |       |      |      |
| <br>L02 Lever | X3C3 ..   | 0.8                     | 2.877 | 0.045                 | 0.161 | 21.8                  | 0.858 | 20.5 ± 0.6         | 0.81 ± 0.024 | 0.35                  | 0.014  | 19.5                     | 0.76  |      |      |
|  | X3M3..    | 2                       | 7.193 | 0.19                  | 0.683 | 21.8                  | 0.858 | 20.5 ± 0.6         | 0.81 ± 0.024 | 0.3                   | 0.011  | 19.5                     | 0.76  |      |      |
| Width of lever 7.0 mm/0.28 in  |           |                         |       |                       |       |                       |       |                    |              |                       |        |                          |       |      |      |
| <br>T02 Lever | X3C3 ..   | 0.8                     | 2.877 | 0.045                 | 0.161 | 21.8                  | 0.858 | 20.2 ± 0.7         | 0.79 ± 0.028 | 0.35                  | 0.014  | 19.3                     | 0.76  |      |      |
|  | X3M3..    | 2                       | 7.193 | 0.19                  | 0.683 | 21.8                  | 0.858 | 20.2 ± 0.7         | 0.79 ± 0.028 | 0.35                  | 0.014  | 19.3                     | 0.76  |      |      |
| Width of roller 6.6 mm/0.26 in   |           |                         |       |                       |       |                       |       |                    |              |                       |        |                          |       |      |      |

## Ordering Reference

|                    |          |  |             |  |   |    |   |   |   |   |    |   |    |
|--------------------|----------|--|-------------|--|---|----|---|---|---|---|----|---|----|
| Basic type         | X3       | Microswitch according to DIN 41635, Design A   | Example: X3 | M  | 3 | 02 | K | 2 | A | A | J0 | 2 | AA |
| Operating force    | M        | Standard force 1   |             |  |   |    |   |   |   |   |    |   |    |
|                    | L        | Standard force 2   |             |  |   |    |   |   |   |   |    |   |    |
|                    | C        | Low force  |             |  |   |    |   |   |   |   |    |   |    |
| Circuit diagram    | 3        | Change-over  |             |  |   |    |   |   |   |   |    |   |    |
|                    | 4        | Normally closed (NC)   |             |  |   |    |   |   |   |   |    |   |    |
|                    | 5        | Normally open (NO)   |             |  |   |    |   |   |   |   |    |   |    |
| Terminals          | 02       | Plug terminal 6.3 × 0.8 mm   | 13          | PCB-terminal, Formed to lid  |   |    |   |   |   |   |    |   |    |
|                    | 03       | Solder terminal  | 14          | PCB-terminal, Formed to base   |   |    |   |   |   |   |    |   |    |
|                    | 06       | Plug terminal 4.8 × 0.5 mm   | 15          | Plug terminal RAST 5 6.3 × 0.8 mm  |   |    |   |   |   |   |    |   |    |
|                    | 10       | Plug terminal 4.8 × 0.8 mm   | 16          | Plug terminal RAST 5 4.8 × 0.8 mm  |   |    |   |   |   |   |    |   |    |
|                    | 12       | Solder terminal, short   |             |  |   |    |   |   |   |   |    |   |    |
| Body               | K        | PA66 GF25  |             |  |   |    |   |   |   |   |    |   |    |
|                    | N        | Compliant to glow wire requirements as to IEC 60335-1, 4. ed.                          |             |  |   |    |   |   |   |   |    |   |    |
| Contacts materials | 2        | Silver/AgNi10  |             |  |   |    |   |   |   |   |    |   |    |
|                    | 6        | AgCd0  |             |  |   |    |   |   |   |   |    |   |    |
|                    | 8        | Gold plated  |             |  |   |    |   |   |   |   |    |   |    |
| UL/C-UL ratings    | A        | 20.5 A, 125/250 VAC<br>15 A, 125/250 VAC, 100'000 cy.<br>1½ HP, 250 VAC, ½ HP, 125 VAC | M           | 6 A, 125/250 VAC<br>½ HP, 250 VAC, ½ HP, 125 VAC                                     |   |    |   |   |   |   |    |   |    |
|                    | D        | 21 A, 125/250 VAC<br>2 HP, 250 VAC, 1 HP, 125 VAC                                      | N           | No approvals   |   |    |   |   |   |   |    |   |    |
|                    | E        | 21 A, 125/250 VAC<br>15 A, 125/250 VAC, 100'000 cy.<br>2 HP, 250 VAC, 1 HP, 125 VAC    | P           | 20.5 A, 125/250 VAC<br>1½ HP, 250 VAC, ½ HP, 125 VAC<br>½ HP, 250 VDC, ½ HP, 125 VDC |   |    |   |   |   |   |    |   |    |
|                    | K        | 20.5 A, 125/250 VAC<br>1½ HP, 250 VAC, ½ HP, 125 VAC                                   | Q           | 12 A, 125/250 VAC<br>½ HP, 250 VAC, ½ HP, 125 VAC<br>¼ A, 250 VDC, ½ A, 125 VDC      |   |    |   |   |   |   |    |   |    |
|                    | L        | 12 A, 125/250 VAC<br>½ HP, 250 VAC, ½ HP, 125 VAC                                      | R           | 6 A, 125/250 VAC<br>½ HP, 250 VAC, ½ HP, 125 VAC<br>¼ A, 250 VDC, ½ A, 125 VDC       |   |    |   |   |   |   |    |   |    |
| EN/IEC ratings     | A        | 16 (6) A, 250 V~ 5E4 T125 µ approved   |             |  |   |    |   |   |   |   |    |   |    |
|                    | B        | 10 (3) A, 250 V~ 5E4 T125 µ approved   |             |  |   |    |   |   |   |   |    |   |    |
|                    | C        | 6 (3) A, 250 V~ 5E4 T125 µ approved  |             |  |   |    |   |   |   |   |    |   |    |
|                    | D        | 21 (8) A, 250 V~ 1E4 T105 µ approved   |             |  |   |    |   |   |   |   |    |   |    |
| Type of actuator   |          | No symbol, without lever   |             |  |   |    |   |   |   |   |    |   |    |
|                    | J0 to J9 | Straight lever (width 7 mm)  |             |  |   |    |   |   |   |   |    |   |    |
|                    | L0 to L9 | Simulated roller lever   |             |  |   |    |   |   |   |   |    |   |    |
|                    | M0 to M9 | Customer specified lever (KV)  |             |  |   |    |   |   |   |   |    |   |    |
|                    | P0 to P9 | Straight lever (width 4 mm)  |             |  |   |    |   |   |   |   |    |   |    |
|                    | T0 to T9 | Roller lever   |             |  |   |    |   |   |   |   |    |   |    |
|                    | U0 to U9 | Outside mounted lever  |             |  |   |    |   |   |   |   |    |   |    |
| Actuator position  |          | No symbol, without lever   |             |  |   |    |   |   |   |   |    |   |    |
|                    | 2        | Rear lever   |             |  |   |    |   |   |   |   |    |   |    |
|                    | 4        | Front lever  |             |  |   |    |   |   |   |   |    |   |    |
| Customer version   |          | No symbol, standard type   |             |  |   |    |   |   |   |   |    |   |    |
|                    | AA to YY | Specials for customers   |             |  |   |    |   |   |   |   |    |   |    |



## 390

Characteristics ■ wiping contacts, leaf spring mechanism  
 ■ Rast 5 terminal option

Rating 250 VAC, 25 A max.

Dimensions 28.8 × 20.4 × 10.1

Actuator ■ plunger  
 ■ plain levers  
 ■ roller levers  
 ■ moulded lever

Approvals ENEC, UL, CSA



## Popular Products

| Ordering Reference | Actuating Force (g) | Operating pos. (mm) | Terminal   | Contact Gap (mm) | Actuator | Contacts | Electrical rating ENEC | UL                   |
|--------------------|---------------------|---------------------|------------|------------------|----------|----------|------------------------|----------------------|
| 393/40/120         | 120                 | 14,4–15,17          | 6,35 × 0,8 | 1                | Plunger  | Ag       | 22 (4) A 250 VAC       | 22 A 1HP 125/250VAC  |
| 393/40/350         | 350                 | 14,4–15,17          | 6,35 × 0,8 | 1                | Plunger  | Ag       | 20 (4) A 250 VAC       | 20 A 1HP 125/250 VAC |

## Specifications

|                   |  |
|-------------------|--|
| Housing           | Glass-filled flame retardant Nylon 6,6                 |
| Plunger           | Glass-filled flame retardant Nylon 6,6                 |
| Mechanism         | Snap action, single pole leaf spring mechanism         |
| Functions         | Change over, Normally open, Normally closed            |
| Contacts          | Silver   |
| Terminals         | Solder, Faston and Rast 5 terminals                    |
| Temperature range | -10°C to +85°C   |
| Mechanical life   | 10 <sup>7</sup> cycles minimum (impact-free actuation) |
| Protection        | IP40 (enclosure)                                       |
| Mounting          | Side mounting  |
| Actuators         | Plunger, plain lever, roller lever                     |

Circuit diagram

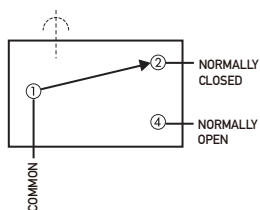

## Dimensions

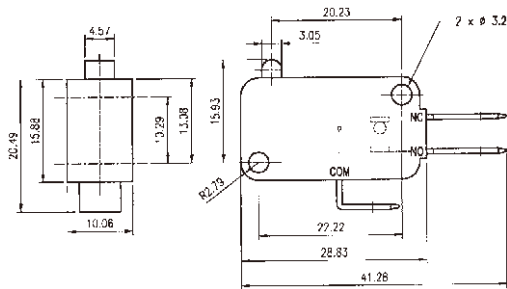

392  
Solder

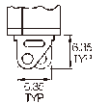

398  
Rast 5  
Fast on

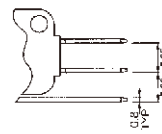
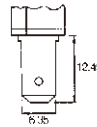

393  
6.35 x 0.8  
Fast on

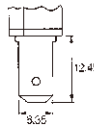

## Recommended maximum electrical ratings A3 shown below

| Versions               | ENEC                         | UL                       |
|------------------------|------------------------------|--------------------------|
| 120 g (only for NO/NC) | 22 (4) A, 250 VAC, 50E3, T85 | 22 A 1HP 125/250 VAC T85 |
| 350 g (only for NO/NC) | 25 (4) A, 250 VAC, 50E3, T85 | 22 A 1HP 125/250 VAC T85 |
| CO                     | 20 (4) A, 250 VAC, 10E3, T85 | 20A, 1HP 125/250 VAC     |

## Operating Characteristics

| Actuator                    | Reference   | Actuating Force Maximum (g) | Release Force Minimum (g) | Free Position Maximum (mm) | Operating Position | Length (mm) | Movement Differential Maximum (mm) | Overtravel Minimum (mm) |
|-----------------------------|-------------|-----------------------------|---------------------------|----------------------------|--------------------|-------------|------------------------------------|-------------------------|
| Plunger                     | 39-/40/120  | 120                         | 40                        | 15.93                      | 14,4-15,17         |             | 0.25                               | 1,32                    |
|                             | 39-/120/350 | 350                         | 100                       | 15.93                      | 14,4-15,17         |             | 0.25                               | 1,32                    |
| Plain lever (Back position) | ZD0         |                             |                           | 16.99                      |                    | 22.56       |                                    |                         |
|                             | ZD1         |                             |                           | 18.61                      |                    | 33.9        |                                    |                         |
|                             | ZD2         |                             |                           | 25.8                       |                    | 84.43       |                                    |                         |
| Roller lever                | ZDS0        |                             |                           | 22.15                      |                    | 19.67       |                                    |                         |
|                             | ZDS1        |                             |                           | 23.86                      |                    | 31.7        |                                    |                         |

## Ordering Reference

|                 |                        |                    |          |  |  |    |     |     |    |     |
|-----------------|------------------------|--------------------|----------|--|--|----|-----|-----|----|-----|
| Basic type      | 39                     | Example: 39        |          |  |  | 2/ | 40/ | 120 | NO | ZD0 |
| Terminal type   | 2                      | Solder             |          |  |  |    |     |     |    |     |
|                 | 3                      | 6,35 × 0,8 fast-on |          |  |  |    |     |     |    |     |
|                 | 8                      | 6,35 × 0,8 Rast 5  |          |  |  |    |     |     |    |     |
| Contact gap     | 40                     | 1 mm standard      |          |  |  |    |     |     |    |     |
| Operating force | 120                    | 120 g              |          |  |  |    |     |     |    |     |
|                 | 350                    | 350 g              |          |  |  |    |     |     |    |     |
| Circuit         | No symbol, change-over |                    |          |  |  |    |     |     |    |     |
|                 | NO                     | Normally open      |          |  |  |    |     |     |    |     |
|                 | NC                     | Normally closed    |          |  |  |    |     |     |    |     |
| Actuator        | No symbol, plunger     |                    |          |  |  |    |     |     |    |     |
|                 | ZD0                    | Plain lever        | 22,5 mm  |  |  |    |     |     |    |     |
|                 | ZD1                    | Plain lever        | 33,9 mm  |  |  |    |     |     |    |     |
|                 | ZD2                    | Plain lever        | 84,4 mm  |  |  |    |     |     |    |     |
|                 | ZDS0                   | Roller lever       | 19,67 mm |  |  |    |     |     |    |     |
|                 | ZDS1                   | Roller lever       | 31,7 mm  |  |  |    |     |     |    |     |

## 340

Characteristics ■ wiping contacts, leaf spring mechanism  
 ■ 3 mm contact gap option

Rating 250 VAC, 16 A max.

Dimensions 28.8 × 20.4 × 10.1

Actuator ■ plunger  
 ■ roller lever  
 ■ plain levers  
 ■ simulated roller lever  
 ■ moulded lever

Approvals ENEC



## Popular Products

| Ordering Reference | Actuating Force (g) | Operating pos. (mm) | Terminal   | Contact Gap (mm) | Actuator | Contacts | Electrical rating ENEC | UL/CSA |
|--------------------|---------------------|---------------------|------------|------------------|----------|----------|------------------------|--------|
| 343/40/75          | 75                  | 14,4–15,17          | 6,35 × 0,8 | 1                | Plunger  | AgCd0    | 16,1 A, 250 VAC        | 10 A   |

## Specifications

|                   |  |
|-------------------|--|
| Housing           | Glass-filled flame retardant Nylon 6,6   |
| Plunger           | Glass-filled flame retardant Nylon 6,6   |
| Mechanism         | Snap action, single pole leaf spring mechanism                                     |
| Functions         | Change-over, Normally open, Normally closed  |
| Contacts          | Silver   |
| Terminals         | Solder, Faston and Rast 5 terminals  |
| Temperature range | -10°C to +85°C   |
| Mechanical life   | 10 <sup>7</sup> cycles minimum (3 mm gap 10 <sup>6</sup> ) (impact-free actuation) |
| Protection        | IP40 (enclosure)   |
| Mounting          | Side mounting  |
| Actuators         | Plunger, plain lever, roller lever   |

Circuit diagram

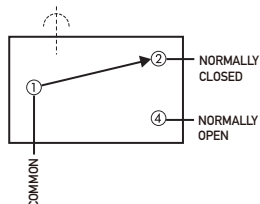

## Dimensions

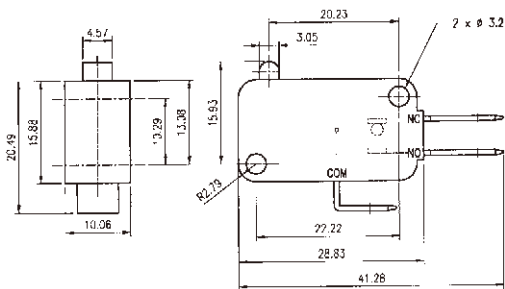

342  
Solder

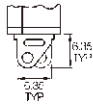

345  
4,75 × 0,5  
Fast on

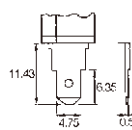

348  
Rast 5  
Fast on

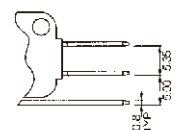
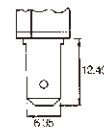

343  
6,35 × 0,8  
Fast on

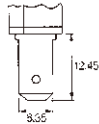

346  
4,75 × 0,8  
Fast on

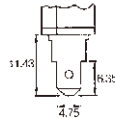

## Recommended maximum electrical ratings A3 sirown below

| Versions              | ENEC   | UL / CSA                | Motor load |
|-----------------------|--|-------------------------|------------|
| 75 g<br>3 mm Wide gap | *16.1 A, 250 VAC, 10 E3, T85<br>16(3) A, 250 VAC, 50 E3, T85 | 10 A 125/250 VAC<br>N/a | ¼ HP       |

\* only for special versions  
345 and 346 terminals 10 (4) A ENEC

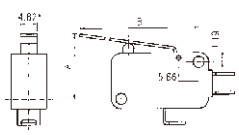
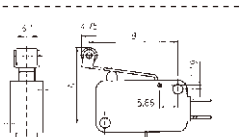

## Operating Characteristics

| Actuator                       | Reference   | Actuating Force Maximum (g) | Release Force Minimum (g) | Free Position Maximum (mm) | Operating Position        | Length (mm) | Movement Differential Maximum (mm) | Overtravel Minimum (mm) |
|--------------------------------|---|-----------------------------|---------------------------|----------------------------|---------------------------|-------------|------------------------------------|-------------------------|
| Plunger                        | 34-/40/75<br>34-/120/350  | 75<br>420                   | 25<br>120                 | 15.93<br>15.93             | 14.4-15.17<br>14.15-14.91 |             | 0.25<br>0.76                       | 1.32<br>1.06            |
| Plain lever<br>(Back position) |  | ZD0                         |                           | 16.99                      |                           | 22.56       |                                    |                         |
|                                |   | ZD1                         |                           | 18.61                      |                           | 33.9        |                                    |                         |
|                                |   | ZD2                         |                           | 25.8                       |                           | 84.43       |                                    |                         |
| Roller lever                   |  | ZDS0                        |                           | 22.15                      |                           | 19.67       |                                    |                         |
|                                |   | ZDS1                        |                           | 23.86                      |                           | 31.7        |                                    |                         |

## Ordering Reference

|                 |  |             |  |  |  |    |     |    |    |     |
|-----------------|--|-------------|--|--|--|----|-----|----|----|-----|
| Basic type      | 34   | Example: 34 |  |  |  | 2/ | 40/ | 75 | NO | ZD0 |
| Terminal type   | 2 solder<br>3 6.35 × 0.8 fast-on<br>5 4.75 × 0.5 fast-on<br>6 4.75 × 0.8 fast-on<br>8 6.35 × 0.8 Rast 5†   |             |  |  |  |    |     |    |    |     |
| Contact gap     | 40 1 mm standard<br>120 3 mm   |             |  |  |  |    |     |    |    |     |
| Operating force | 75 75 g<br>350 420 g (3 mm gap)  |             |  |  |  |    |     |    |    |     |
| Circuit         | No symbol, change-over<br>NO Normally open<br>NC Normally closed   |             |  |  |  |    |     |    |    |     |
| Actuator        | No symbol, plunger<br>ZD0 Plain lever 22.5 mm<br>ZD1 Plain lever 33.9 mm<br>ZD2 Plain lever 84.4 mm<br><br>ZDS0 Roller lever 19.67 mm<br>ZDS1 Roller lever 31.7 mm |             |  |  |  |    |     |    |    |     |

# Low operating force Microswitches



Circuit diagram

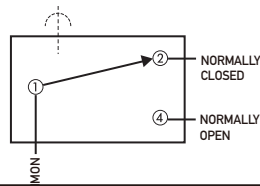

Dimension

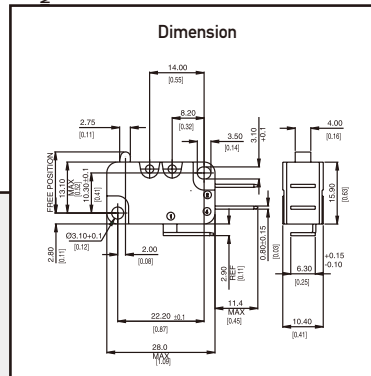

Miniature



innovating motion

## G3

|                 |  |
|-----------------|--|
| Characteristics | <ul style="list-style-type: none"> <li>■ low operating force, high current capacity</li> <li>■ &lt; 15 cn operating force option</li> <li>■ &gt; 3 mm contact gap, change-over mechanism option</li> </ul> |
| Rating          | Up to 250 VAC, 18 A  |
| Dimensions (mm) | 28 × 16 × 10   |
| Actuator        | <ul style="list-style-type: none"> <li>■ plunger</li> <li>■ ramp plunger</li> </ul>  |
| Approvals       | ENEC, UL, CSA  |



## Preferred Range

| Ordering Reference | Actuating Force<br>(N) (ozf) |      | Sealing | Operating pos.<br>(mm) (in) |      | Terminal         | Circuit | Actuator      | Contacts    | Electrical rating   |
|--------------------|------------------------------|------|---------|-----------------------------|------|------------------|---------|---------------|-------------|---------------------|
| G3M1T1RULAU        | 0.15                         | 0.54 | IP40    | 14.7                        | 0.57 | Faston 6.3 × 0.8 | CO      | Ramp plunger  | Gold plated | Up to 250 VAC, 7 A  |
| G3M1T1PULAU        | 0.15                         | 0.54 | IP40    | 14.7                        | 0.57 | Faston 6.3 × 0.8 | CO      | Plain plunger | Gold plated | Up to 250 VAC, 7 A  |
| G3M1T1RU-L         | 0.15                         | 0.54 | IP40    | 14.7                        | 0.57 | Faston 6.3 × 0.8 | CO      | Ramp plunger  | Ag          | Up to 250 VAC, 7 A  |
| G3M1T1PUL          | 0.15                         | 0.54 | IP40    | 14.7                        | 0.57 | Faston 6.3 × 0.8 | CO      | Plain plunger | Ag          | Up to 250 VAC, 7 A  |
| G3M1T2RUL          | 0.15                         | 0.54 | IP40    | 14.7                        | 0.57 | Faston 4.8 × 0.8 | CO      | Ramp plunger  | Ag          | Up to 250 VAC, 7 A  |
| G3M1T2PUL          | 0.15                         | 0.54 | IP40    | 14.7                        | 0.57 | Faston 4.8 × 0.8 | CO      | Plain plunger | Ag          | Up to 250 VAC, 7 A  |
| G3M1T3RUL          | 0.15                         | 0.54 | IP40    | 14.7                        | 0.57 | Faston 4.8 × 0.5 | CO      | Ramp plunger  | Ag          | Up to 250 VAC, 7 A  |
| G3M1T3PUL          | 0.15                         | 0.54 | IP40    | 14.7                        | 0.57 | Faston 4.8 × 0.5 | CO      | Plain plunger | Ag          | Up to 250 VAC, 7 A  |
| G3M1T4RUL          | 0.15                         | 0.54 | IP40    | 14.7                        | 0.57 | Solder           | CO      | Ramp plunger  | Ag          | Up to 250 VAC, 7 A  |
| G3M1T4PUL          | 0.15                         | 0.54 | IP40    | 14.7                        | 0.57 | Solder           | CO      | Plain plunger | Ag          | Up to 250 VAC, 7 A  |
| G3G4T1RUL          | 2.70                         | 7.20 | IP40    | 14.5                        | 0.57 | Faston 6.3 × 0.8 | CO      | Ramp plunger  | > 3mm gap   | Up to 250 VAC, 10 A |
| G3G4T1PUL          | 2.70                         | 7.20 | IP40    | 14.5                        | 0.57 | Faston 6.3 × 0.8 | CO      | Plain plunger | > 3mm gap   | Up to 250 VAC, 10 A |

## Specifications

|                      |  |
|----------------------|--|
| Housing              | Flame retardant glass-filled nylon   |
| Plunger              | Flame retardant glass-filled nylon   |
| Mechanism            | Snap-action, single pole - beryllium copper trident spring   |
| Functions            | Change-over, Normally open, Normally closed  |
| Contacts             | Fixed - Silver cadmium oxide or gold plate on silver cadmium oxide, Moving - Silver or gold plate on silver                          |
| Terminals            | 6.3 mm (0.25 in), 4.8 mm (0.19 in) faston: NC (2), NO (4) - Brass, Common (1) - Brass, silver-plated<br>Solder: Brass, silver-plated |
| Temperature range °C | -40°C to + 85°C  |
| Mechanical life      | 10 <sup>6</sup> to 10 <sup>7</sup> cycles minimum (impact free actuation) - dependent on operating force                             |
| Protection           | IP 40 (enclosure)  |
| Mounting             | Side mounting  |
| Actuators            | Plain plunger, Ramp plunger  |

Circuit diagram

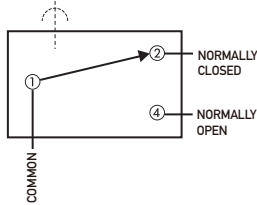

Dimensions G3M

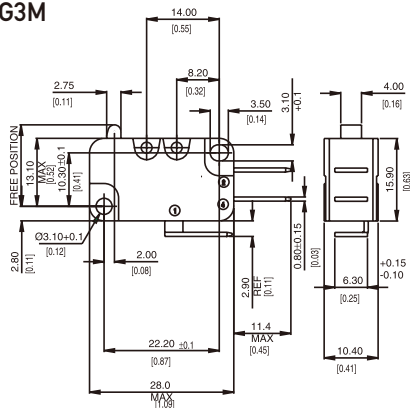

Dimensions G3G

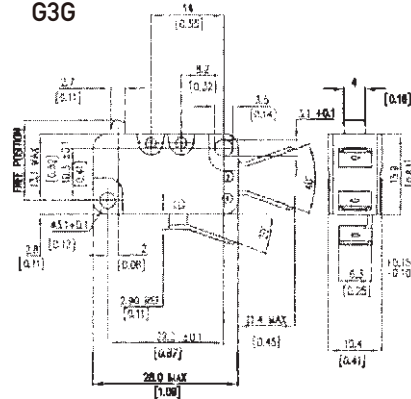

## Recommended maximum electrical ratings

|      | Voltage (max) | Load (A)       | Inductive load (A) | Approval                                   |
|------|---------------|----------------|--------------------|--|
| G3M1 | 250 VAC       | 7 (0.75 pf)    |                    | UL 1054/CSA 22.2 No. 55 - 6,000 operations |
|      | 250 VAC       | 6              | 2                  | EN61058-1, T85, 50,000 operations          |
| G3M2 | 250 VAC       | 10.1 (0.75 pf) |                    | UL 1054/CSA 22.2 No. 55 - 6,000 operations |
|      | 250 VAC       | 10             | 3                  | EN61058-1, T85, 50,000 operations          |
| G3M3 | 250 VAC       | 15 (0.75 pf)   |                    | UL 1054/CSA 22.2 No. 55 - 6,000 operations |
|      | 250 VAC       | 16             | 4                  | EN61058-1, T85, 10,000 operations          |
| G3M4 | 250 VAC       | 18 (0.75 pf)   |                    | UL 1054/CSA 22.2 No. 55 - 6,000 operations |
|      | 250 VAC       | 18             | 4                  | EN61058-1, T85, 10,000 operations          |
| G3G4 | 250 VAC       | 10.1 (0.75 pf) |                    | UL 1054/CSA 22.2 No. 55 - 6,000 operations |
|      | 250 VAC       | 10             | 3                  | EN61058-1, T85, 10,000 operations          |

## Operating Characteristics

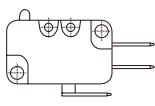
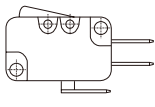
| Actuator   | Reference | Actuating Force Maximum |       | Release Force Minimum |       | Free Position Maximum |       | Operating Position |      | Movement Differential |      | Over travel Maximum |   |
|--|-----------|-------------------------|-------|-----------------------|-------|-----------------------|-------|--------------------|------|-----------------------|------|---------------------|---|
|  |           | (N)                     | (ozf) | (N)                   | (ozf) | (mm)                  | (in)  | (mm)               | (in) | (mm)                  | (in) |                     |   |
| Plain plunger<br> | G3M1..P   | 0.15                    | 0.54  | 0.005                 | 0.02  | 15.9                  | 0.625 | 14.7 ± 0.3         | 0.57 | } +0,01<br>} -0,001   | 0.2  | 0.008               | * |
|  | G3M2..P   | 0.70                    | 2.52  | 0.200                 | 0.72  | 15.9                  | 0.625 | 14.7 ± 0.3         | 0.57 |                       | 0.2  | 0.008               |   |
|  | G3M3..P   | 1.10                    | 3.96  | 0.300                 | 1.08  | 15.9                  | 0.625 | 14.7 ± 0.3         | 0.57 |                       | 0.2  | 0.008               |   |
|  | G3M4..P   | 1.70                    | 6.11  | 0.500                 | 1.80  | 15.9                  | 0.625 | 14.7 ± 0.3         | 0.57 |                       | 0.2  | 0.008               |   |
|  | G3G4..P   | 2.70                    | 7.20  | 0.200                 | 0.72  | 15.9                  | 0.625 | 14.5 ± 0.3         | 0.57 |                       | 0.5  | 0.020               |   |
| Ramp plunger<br>  | G3M1..R   | 0.15                    | 0.54  | 0.005                 | 0.02  | 15.9                  | 0.625 | 14.7 ± 0.3         | 0.57 | } +0,01<br>} -0,001   | 0.2  | 0.008               | * |
|  | G3M2..R   | 0.70                    | 2.52  | 0.200                 | 0.72  | 15.9                  | 0.625 | 14.7 ± 0.3         | 0.57 |                       | 0.2  | 0.008               |   |
|  | G3M3..R   | 1.10                    | 3.96  | 0.300                 | 1.08  | 15.9                  | 0.625 | 14.7 ± 0.3         | 0.57 |                       | 0.2  | 0.008               |   |
|  | G3M4..R   | 1.70                    | 6.11  | 0.500                 | 1.80  | 15.9                  | 0.625 | 14.7 ± 0.3         | 0.57 |                       | 0.2  | 0.008               |   |
|  | G3G4..R   | 2.70                    | 7.20  | 0.200                 | 0.72  | 15.9                  | 0.625 | 14.5 ± 0.3         | 0.57 |                       | 0.5  | 0.020               |   |

\* Plunger can be depressed flush with housing. The housing should not be used as an end stop.

## Ordering Reference

|                          |    |  |                               |      |            |  |  |  |  |  |  |  |
|--------------------------|----|--|-------------------------------|------|------------|--|--|--|--|--|--|--|
| Basic type               | G3 | Example: G3   M   1   T1   P   C2   UL   AU          |                               |      |            |  |  |  |  |  |  |  |
| Contact gap              | M  | Microgap   |                               |      |            |  |  |  |  |  |  |  |
|                          | G  | > 3 mm gap   |                               |      |            |  |  |  |  |  |  |  |
| Actuating Characteristic | 1  | 0.15   |                               |      |            |  |  |  |  |  |  |  |
|                          | 2  | 0.70   |                               |      |            |  |  |  |  |  |  |  |
|                          | 3  | 1.10   |                               |      |            |  |  |  |  |  |  |  |
|                          | 4  | 1.70   | Microgap                      | 2.70 | > 3 mm gap |  |  |  |  |  |  |  |
| Terminals                | T1 | Faston 6.3 × 0.8                                     |                               |      |            |  |  |  |  |  |  |  |
|                          | T2 | Faston 4.8 × 0.8                                     |                               |      |            |  |  |  |  |  |  |  |
|                          | T3 | Faston 4.8 × 0.5 (microgap only)                     |                               |      |            |  |  |  |  |  |  |  |
|                          | T4 | Solder   |                               |      |            |  |  |  |  |  |  |  |
| Note:                    |    | Microgap - parallel terminals;                       | > 3 mm gap - flared terminals |      |            |  |  |  |  |  |  |  |
| Actuators                | P  | Plain plunger  |                               |      |            |  |  |  |  |  |  |  |
|                          | R  | Ramp plunger   |                               |      |            |  |  |  |  |  |  |  |
| Circuit                  |    | No symbol, change-over                               |                               |      |            |  |  |  |  |  |  |  |
|                          | C2 | Normally closed                                      |                               |      |            |  |  |  |  |  |  |  |
|                          | C4 | Normally open  |                               |      |            |  |  |  |  |  |  |  |
| Approvals                |    | No symbol, ENEC                                      |                               |      |            |  |  |  |  |  |  |  |
|                          | UL | UL and CSA   |                               |      |            |  |  |  |  |  |  |  |
| Contacts                 |    | No symbol, silver, silver cadmium oxide              |                               |      |            |  |  |  |  |  |  |  |
|                          | AU | Gold plated silver, gold plated silver cadmium oxide |                               |      |            |  |  |  |  |  |  |  |

# Table of preferred products

| Snap-action Microswitches | Type       | Preferred Products | Preferred Products | Page |               |               |    |
|---------------------------|------------|--------------------|--------------------|------|---------------|---------------|----|
| Subminiature              | XC         | XCG3Z1             | XCG8-81-J1Z1       | 18   |               |               |    |
|                           |            | XCG3-J1Z1          | XCG8-81-S1Z1       |      |               |               |    |
|                           |            | XCG3-S1Z1          | XCF3Z1             |      |               |               |    |
|                           |            | XCG5Z1             | XCF3-J1Z1          |      |               |               |    |
|                           |            | XCG5-J1Z1          | XCF3-S1Z1          |      |               |               |    |
|                           |            | XCG5-S1Z1          | XCG3-U1Z1          |      |               |               |    |
|                           |            | XCG8Z1             | XCG4-U1Z1          |      |               |               |    |
|                           |            | XCG8-81Z1          | XCG8-U1Z1          |      |               |               |    |
| X4                        | X4         | X4F303K1AA         | X4G305K1BB         | 23   |               |               |    |
|                           |            | X4F305K1AA         | X4C303K1CC         |      |               |               |    |
|                           |            | X4G303K1BB         | X4C305K1CC         |      |               |               |    |
| V4N                       | V4N        | V4NT7UL            | V4NSY1UL           | 28   |               |               |    |
|                           |            | V4NST7UL           | V4NT7YRUL          |      |               |               |    |
|                           |            | V4NSUL             | V4NST7YRUL         |      |               |               |    |
|                           |            | V4NT7Y1UL          | V4NSYRUL           |      |               |               |    |
|                           |            | V4NST7Y1UL         |                    |      |               |               |    |
| V4NC                      | V4NC       | V4NCT7             | V4NCS              | 32   |               |               |    |
|                           |            | V4NCT7A1           | V4NCSA1            |      |               |               |    |
|                           |            | V4NCT7AR           | V4NCSAR            |      |               |               |    |
| Miniature                 | XG         | XGG2-88Z1          | XGK2-88Z1          | 37   |               |               |    |
|                           |            | XGG2-88-J23Z1      | XGK2-88-J26Z1      |      |               |               |    |
|                           |            | XGG2-88-J26Z1      | XGK2-88-S21Z1      |      |               |               |    |
|                           |            | XGG2-88-J27Z1      | XGK3-88Z1          |      |               |               |    |
|                           |            | XGG2-88-S20Z1      | XGK6-88Z1          |      |               |               |    |
|                           |            | XGG2-88-S21Z1      | XG02-88Z1          |      |               |               |    |
|                           |            | XGG3-88Z1          | XG02-88-J27Z1      |      |               |               |    |
|                           |            | XGG6-88Z1          | XG02-88-S20Z1      |      |               |               |    |
|                           |            | XGC2-88Z1          | XG06-88Z1          |      |               |               |    |
|                           |            | XGC2-88-J23Z1      |                    |      |               |               |    |
|                           |            | XGC2-88-S20Z1      |                    |      |               |               |    |
|                           |            | XGC6-88Z1          |                    |      |               |               |    |
|                           |            | X3                 | X3                 |      | X3M302K2KA    | X3C302K2LB    | 42 |
|                           |            |                    |                    |      | X3M302K2KAJ32 | X3C302K2LBJ32 |    |
| X3M302K2KAJ62             | X3C303K2LB |                    |                    |      |               |               |    |
| X3M302K2KAT02             | X3C306K2LB |                    |                    |      |               |               |    |
| X3M303K2KA                | X3L302K6DD |                    |                    |      |               |               |    |
| X3M306K2KA                | X3L303K6DD |                    |                    |      |               |               |    |
| 390                       | 390        | 393/40/120         |                    | 47   |               |               |    |
|                           |            | 393/40/350         |                    |      |               |               |    |
| 340                       | 340        | 343/40/75          |                    | 50   |               |               |    |
|                           |            | 343/120/350        |                    |      |               |               |    |
| G3                        | G3         | G3M1T1RULAU        | G3M1T3RUL          | 54   |               |               |    |
|                           |            | G3M1T1PULAU        | G3M1T3PUL          |      |               |               |    |
|                           |            | G3M1T1RUL          | G3M1T4RUL          |      |               |               |    |
|                           |            | G3M1T1PUL          | G3M1T4PUL          |      |               |               |    |
|                           |            | G3M1T2RUL          | G3G4T1RUL          |      |               |               |    |
|                           |            | G3M1T2PUL          | G3G4T1PUL          |      |               |               |    |