

Serial E<sup>2</sup>PROM

FEATURES

- 2.7V to 5.5V Power Supply
- Low Power CMOS
  - Active Read Current Less Than 1 mA
  - Active Write Current Less Than 3 mA
  - Standby Current Less Than 50  $\mu$ A
- Internally Organized 512 x 8
- 2 Wire Serial Interface
  - Bidirectional Data Transfer Protocol
- Sixteen Byte Page Write Mode
  - Minimizes Total Write Time Per Byte
- Self Timed Write Cycle
  - Typical Write Cycle Time of 5 ms
- High Reliability
  - Endurance: 100,000 Cycles
  - Data Retention: 100 Years
- 8 Pin Mini-DIP, 8 Pin SOIC and 14 Pin SOIC Packages

DESCRIPTION

The X24C04 is a CMOS 4096 bit serial E<sup>2</sup>PROM, internally organized 512 x 8. The X24C04 features a serial interface and software protocol allowing operation on a simple two wire bus.

The X24C04 is fabricated with Xicor's advanced CMOS Textured Poly Floating Gate Technology.

The X24C04 utilizes Xicor's proprietary DirectWrite™ cell providing a minimum endurance of 100,000 cycles and a minimum data retention of 100 years.

2

FUNCTIONAL DIAGRAM

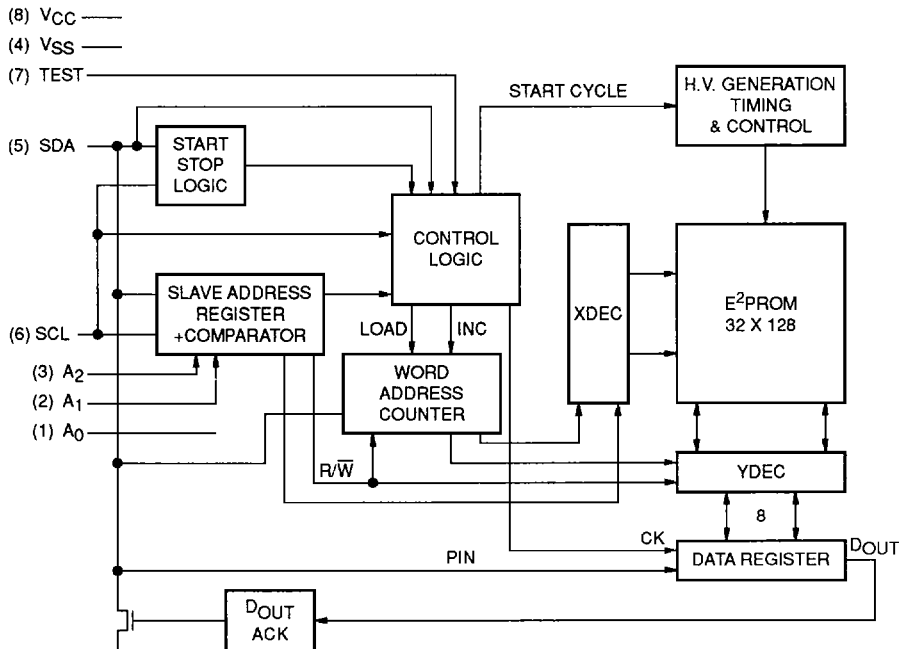

3839 FHD F01

# X24C04

## PIN DESCRIPTIONS

### Serial Clock (SCL)

The SCL input is used to clock all data into and out of the device.

### Serial Data (SDA)

SDA is a bidirectional pin used to transfer data into and out of the device. It is an open drain output and may be wire-ORed with any number of open drain or open collector outputs.

An open drain output requires the use of a pull-up resistor. For selecting typical values, refer to the Pull-Up Resistor selection graph at the end of this data sheet.

### Address (A<sub>0</sub>)

A<sub>0</sub> is unused by the X24C04, however, it must be tied to V<sub>SS</sub> to insure proper device operation.

### Address (A<sub>1</sub>, A<sub>2</sub>)

The Address inputs are used to set the appropriate bits of the seven bit slave address. These inputs can be used static or actively driven. If used statically they must be tied to V<sub>SS</sub> or V<sub>CC</sub> as appropriate. If driven they must be driven to V<sub>SS</sub> or to V<sub>CC</sub>.

## PIN NAMES

Symbol	Description
A <sub>0</sub> -A <sub>2</sub>	Address Inputs
SDA	Serial Data
SCL	Serial Clock
TEST	Hold at V <sub>SS</sub>
V <sub>SS</sub>	Ground
V <sub>CC</sub>	Supply Voltage
NC	No Connect

3839 PGM T01

## PIN CONFIGURATION

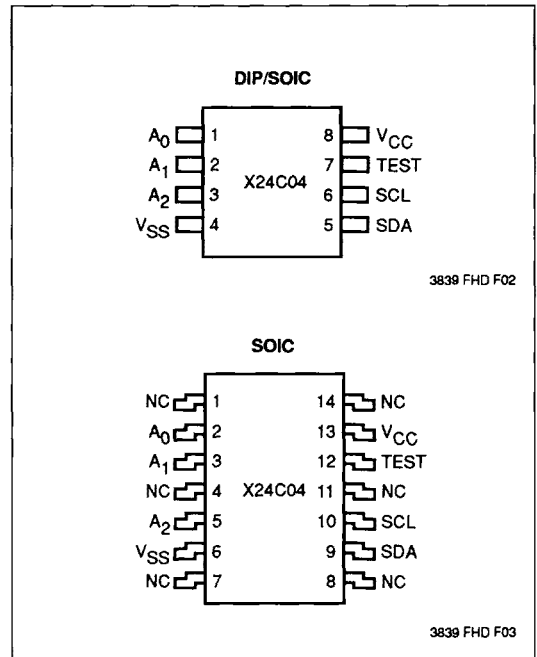

# X24C04

## DEVICE OPERATION

The X24C04 supports a bidirectional bus oriented protocol. The protocol defines any device that sends data onto the bus as a transmitter, and the receiving device as the receiver. The device controlling the transfer is a master and the device being controlled is the slave. The master will always initiate data transfers, and provide the clock for both transmit and receive operations. Therefore, the X24C04 will be considered a slave in all applications.

## Clock and Data Conventions

Data states on the SDA line can change only during SCL LOW. SDA state changes during SCL HIGH are reserved for indicating start and stop conditions. Refer to Figures 1 and 2.

### Start Condition

All commands are preceded by the start condition, which is a HIGH to LOW transition of SDA when SCL is HIGH. The X24C04 continuously monitors the SDA and SCL lines for the start condition and will not respond to any command until this condition has been met.

2

Figure 1. Data Validity

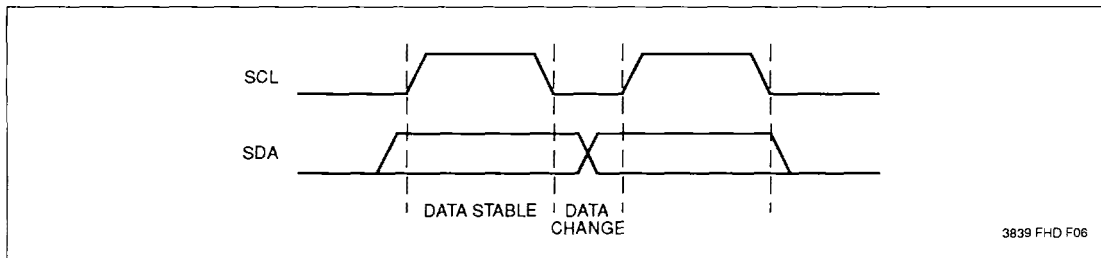
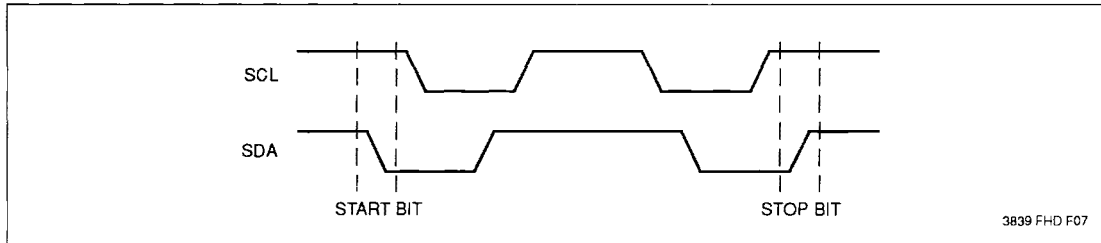

Figure 2. Definition of Start and Stop



# X24C04

## Stop Condition

All communications must be terminated by a stop condition, which is a LOW to HIGH transition of SDA when SCL is HIGH. The stop condition is also used by the X24C04 to place the device in the standby power mode after a read sequence. A stop condition can only be issued after the transmitting device has released the bus.

## Acknowledge

Acknowledge is a software convention used to indicate successful data transfer. The transmitting device, either master or slave, will release the bus after transmitting eight bits. During the ninth clock cycle the receiver will pull the SDA line LOW to acknowledge that it received the eight bits of data. Refer to Figure 3.

The X24C04 will respond with an acknowledge after recognition of a start condition and its slave address. If both the device and a write operation have been selected, the X24C04 will respond with an acknowledge after the receipt of each subsequent eight bit word.

In the read mode the X24C04 will transmit eight bits of data, release the SDA line and monitor the line for an acknowledge. If an acknowledge is detected and no stop condition is generated by the master, the X24C04 will continue to transmit data. If an acknowledge is not detected, the X24C04 will terminate further data transmissions. The master must then issue a stop condition to return the X24C04 to the standby power mode and place the device into a known state.

Figure 3. Acknowledge Response From Receiver

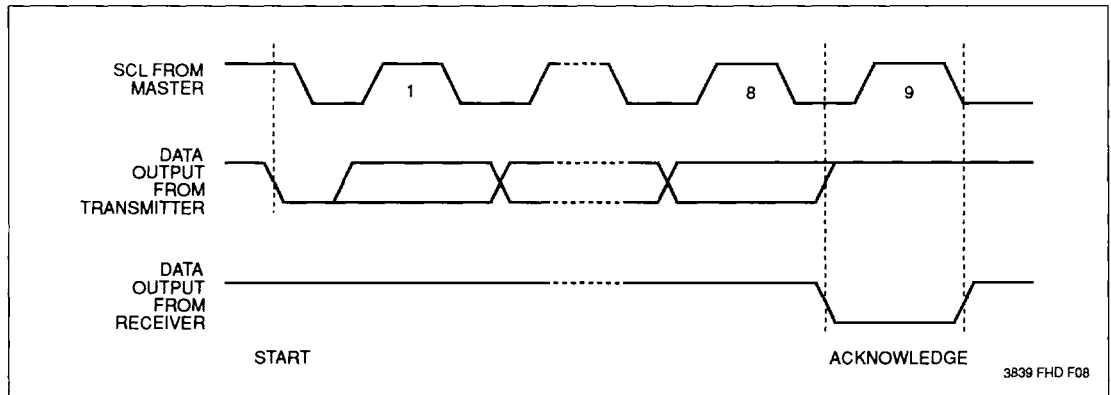

# X24C04

## DEVICE ADDRESSING

Following a start condition the master must output the address of the slave it is accessing. The most significant four bits of the slave are the device type identifier (see Figure 4). For the X24C04 this is fixed as 1010[B].

Figure 4. Slave Address

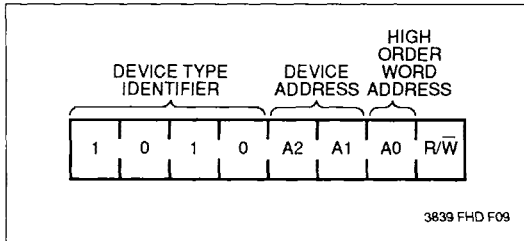

The next two significant bits address a particular device. A system could have up to four X24C04 devices on the bus (see Figure 10). The four addresses are defined by the state of the A<sub>1</sub> and A<sub>2</sub> inputs.

The next bit of the slave address is an extension of the array's address and is concatenated with the eight bits of address in the word address field, providing direct access to the whole 512 x 8 array.

Figure 5. Byte Write

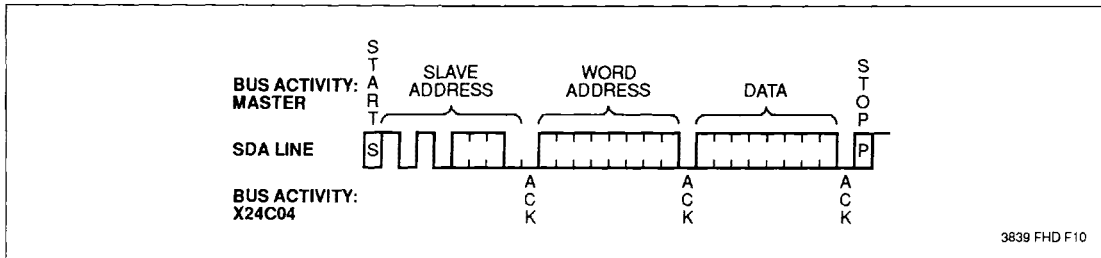

The last bit of the slave address defines the operation to be performed. When set to one a read operation is selected, when set to zero a write operation is selected.

Following the start condition, the X24C04 monitors the SDA bus comparing the slave address being transmitted with its slave address (device type and state of A<sub>1</sub> and A<sub>2</sub> inputs). Upon a correct compare the X24C04 outputs an acknowledge on the SDA line. Depending on the state of the R/W bit, the X24C04 will execute a read or write operation.

## WRITE OPERATIONS

### Byte Write

For a write operation, the X24C04 requires a second address field. This address field is the word address, comprised of eight bits, providing access to any one of the 512 words of memory. Upon receipt of the word address the X24C04 responds with an acknowledge, and awaits the next eight bits of data, again responding with an acknowledge. The master then terminates the transfer by generating a stop condition, at which time the X24C04 begins the internal write cycle to the nonvolatile memory. While the internal write cycle is in progress the X24C04 inputs are disabled, and the device will not respond to any requests from the master. Refer to Figure 5 for the address, acknowledge and data transfer sequence.

# X24C04

## Page Write

The X24C04 is capable of a sixteen byte page write operation. It is initiated in the same manner as the byte write operation, but instead of terminating the write cycle after the first data word is transferred, the master can transmit up to fifteen more words. After the receipt of each word, the X24C04 will respond with an acknowledge.

After the receipt of each word, the four low order address bits are internally incremented by one. The high order five bits of the address remain constant. If the master should transmit more than sixteen words prior to generating the stop condition, the address counter will "roll over" and the previously written data will be overwritten. As with the byte write operation, all inputs are disabled until completion of the internal write cycle. Refer to Figure 6 for the address, acknowledge and data transfer sequence.

## Acknowledge Polling

The disabling of the inputs can be used to take advantage of the typical 5 ms write cycle time. Once the stop condition is issued to indicate the end of the host's write operation the X24C04 initiates the internal write cycle. ACK polling can be initiated immediately. This involves issuing the start condition followed by the slave address for a write operation. If the X24C04 is still busy with the write operation no ACK will be returned. If the X24C04 has completed the write operation an ACK will be returned and the host can then proceed with the next read or write operation. Refer to Flow 1.

## READ OPERATIONS

Read operations are initiated in the same manner as write operations with the exception that the R/W bit of the slave address is set to a one. There are three basic read operations: current address read, random read and sequential read.

It should be noted that the ninth clock cycle of the read operation is not a "don't care." To terminate a read operation, the master must either issue a stop condition during the ninth cycle or hold SDA HIGH during the ninth clock cycle and then issue a stop condition.

Flow 1. ACK Polling Sequence

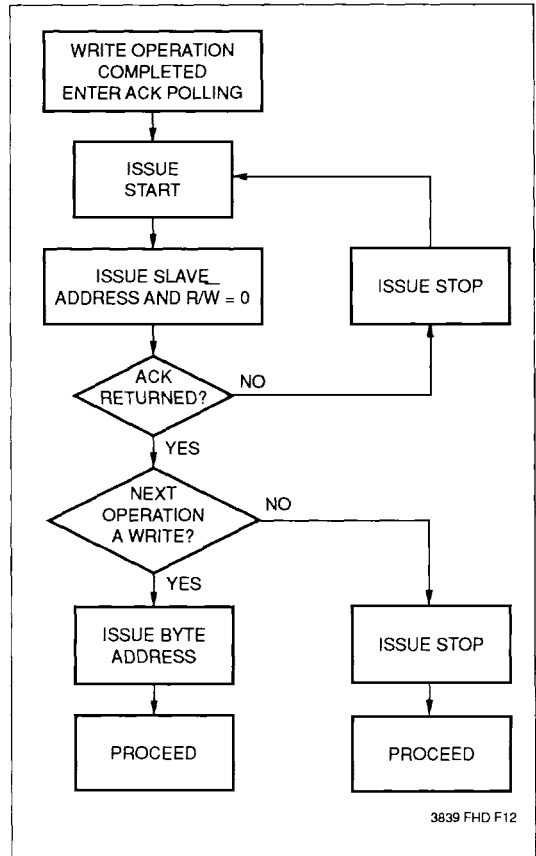
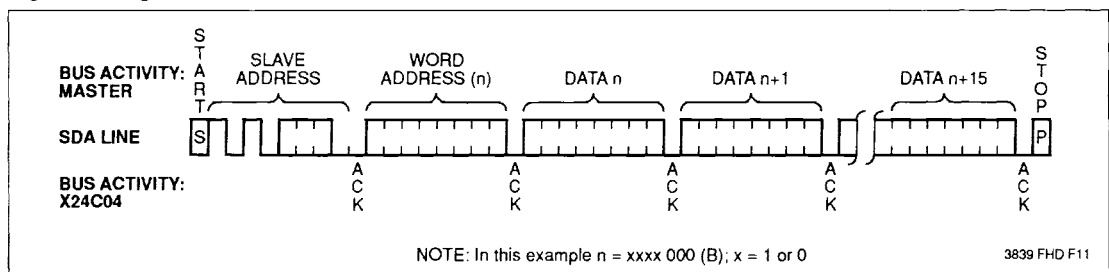

Figure 6. Page Write



# X24C04

## Current Address Read

Internally the X24C04 contains an address counter that maintains the address of the last word accessed, incremented by one. Therefore, if the last access (either a read or write) was to address  $n$ , the next read operation would access data from address  $n + 1$ . Upon receipt of the slave address with the  $R/\bar{W}$  bit set to one, the X24C04 issues an acknowledge and transmits the eight bit word. The read operation is terminated by the master; by not responding with an acknowledge and by issuing a stop condition. Refer to Figure 7 for the sequence of address, acknowledge and data transfer.

## Random Read

Random read operations allow the master to access any memory location in a random manner. Prior to issuing the slave address with the  $R/\bar{W}$  bit set to one, the master must first perform a "dummy" write operation. The master issues the start condition, and the slave address followed by the word address it is to read. After the word address acknowledge, the master immediately reissues the start condition and the slave address with the  $R/\bar{W}$  bit set to one. This will be followed by an acknowledge from the X24C04 and then by the eight bit word. The read operation is terminated by the master; by not responding with an acknowledge and by issuing a stop condition. Refer to Figure 8 for the address, acknowledge and data transfer sequence.

2

Figure 7. Current Address Read

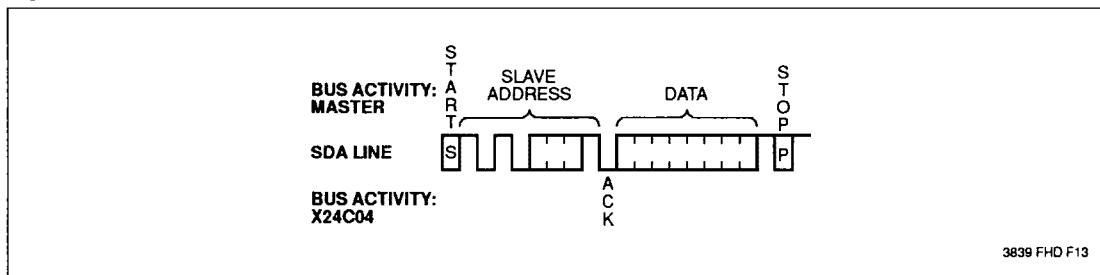
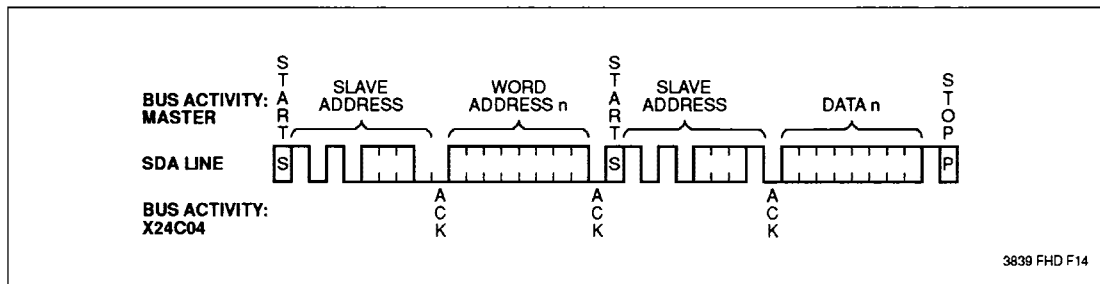

Figure 8. Random Read



# X24C04

## Sequential Read

Sequential Read can be initiated as either a current address read or random access read. The first word is transmitted as with the other modes, however, the master now responds with an acknowledge, indicating it requires additional data. The X24C04 continues to output data for each acknowledge received. The read operation is terminated by the master; by not responding with an acknowledge and by issuing a stop condition.

The data output is sequential, with the data from address  $n$  followed by the data from  $n + 1$ . The address counter for read operations increments all address bits, allowing the entire memory contents to be serially read during one operation. At the end of the address space (address 511), the counter "rolls over" to address 0 and the X24C04 continues to output data for each acknowledge received. Refer to Figure 9 for the address, acknowledge and data transfer sequence.

Figure 9. Sequential Read

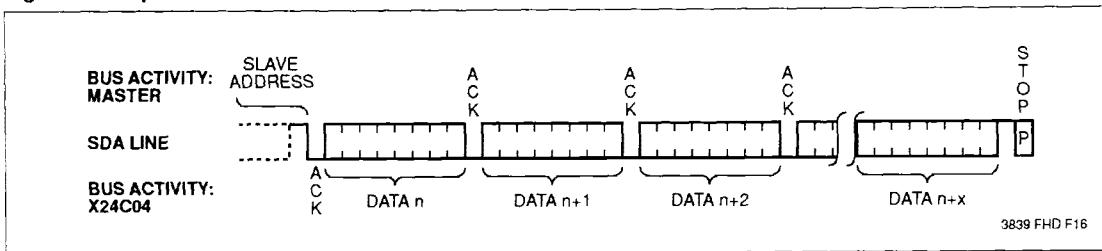
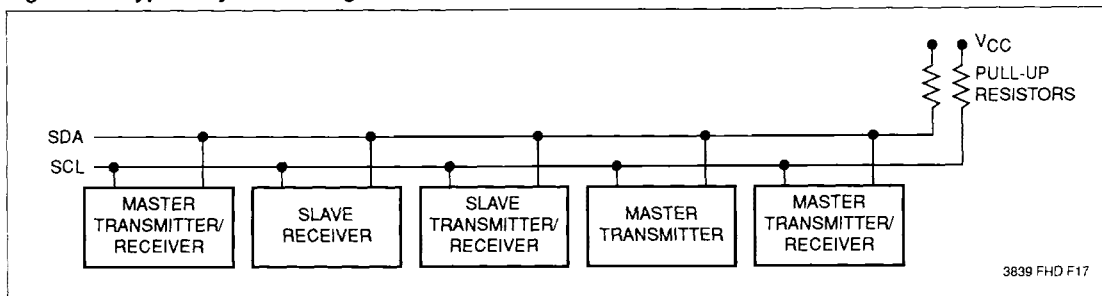

Figure 10. Typical System Configuration





# X24C04

## ABSOLUTE MAXIMUM RATINGS\*

Temperature Under Bias .....	-65°C to +135°C
Storage Temperature .....	-65°C to +150°C
Voltage on any Pin with Respect to V <sub>SS</sub> .....	-1.0V to +7.0V
D.C. Output Current .....	5 mA
Lead Temperature (Soldering, 10 Seconds) .....	300°C

## \*COMMENT

Stresses above those listed under "Absolute Maximum Ratings" may cause permanent damage to the device. This is a stress rating only and the functional operation of the device at these or any other conditions above those indicated in the operational sections of this specification is not implied. Exposure to absolute maximum rating conditions for extended periods may affect device reliability.

## RECOMMENDED OPERATING CONDITIONS

Temperature	Min.	Max.
Commercial	0°C	70°C
Industrial	-40°C	+85°C
Military	-55°C	+125°C

3836 PGM T02

Supply Voltage	Limits
X24C04	4.5V to 5.5V
X24C04-3.5	3.5V to 5.5V
X24C04-3	3V to 5.5V
X24C04-2.7	2.7V to 5.5V

3836 PGM T03

## D.C. OPERATING CHARACTERISTICS (Over recommended operating conditions unless otherwise specified)

Symbol	Parameter	Limits		Units	Test Conditions
		Min.	Max.		
I <sub>CC1</sub>	V <sub>CC</sub> Supply Current (Read)		1	mA	SCL = V <sub>CC</sub> x 0.1/V <sub>CC</sub> x 0.9 Levels @ 100 KHz, SDA = Open, All Other Inputs = GND or V <sub>CC</sub> - 0.3V
I <sub>CC2</sub>	V <sub>CC</sub> Supply Current (Write)		3		
I <sub>SB1</sub> ( <sup>1</sup> )	V <sub>CC</sub> Standby Current		150	μA	SCL = SDA = V <sub>CC</sub> - 0.3V, All Other Inputs = GND or V <sub>CC</sub> , V <sub>CC</sub> = 5.5V
I <sub>SB2</sub> ( <sup>1</sup> )	V <sub>CC</sub> Standby Current		50	μA	SCL = SDA = V <sub>CC</sub> - 0.3V, All Other Inputs = GND or V <sub>CC</sub> , V <sub>CC</sub> = 3V
I <sub>LI</sub>	Input Leakage Current		10	μA	V <sub>IN</sub> = GND to V <sub>CC</sub>
I <sub>LO</sub>	Output Leakage Current		10	μA	V <sub>OUT</sub> = GND to V <sub>CC</sub>
V <sub>IL</sub> ( <sup>2</sup> )	Input Low Voltage	-1.0	V <sub>CC</sub> x 0.3	V	
V <sub>IH</sub> ( <sup>2</sup> )	Input High Voltage	V <sub>CC</sub> x 0.7	V <sub>CC</sub> + 0.5	V	
V <sub>OL</sub>	Output Low Voltage		0.4	V	I <sub>OL</sub> = 3 mA

3839 PGM T03

## CAPACITANCE T<sub>A</sub> = 25°C, f = 1.0MHz, V<sub>CC</sub> = 5V

Symbol	Parameter	Max.	Units	Test Conditions
C <sub>I/O</sub> ( <sup>3</sup> )	Input/Output Capacitance (SDA)	8	pF	V <sub>I/O</sub> = 0V
C <sub>IN</sub> ( <sup>3</sup> )	Input Capacitance (A <sub>0</sub> , A <sub>1</sub> , A <sub>2</sub> , SCL)	6	pF	V <sub>IN</sub> = 0V

3839 PGM T05

- Notes:** (1) Must perform a stop command prior to measurement.  
 (2) V<sub>IL</sub> min. and V<sub>IH</sub> max. are for reference only and are not tested.  
 (3) This parameter is periodically sampled and not 100% tested.

# X24C04

## A.C. CONDITIONS OF TEST

Input Pulse Levels	$V_{CC} \times 0.1$ to $V_{CC} \times 0.9$
Input Rise and Fall Times	10 ns
Input and Output Timing Levels	$V_{CC} \times 0.5$

3839 PGM T02

## EQUIVALENT A.C. LOAD CIRCUIT

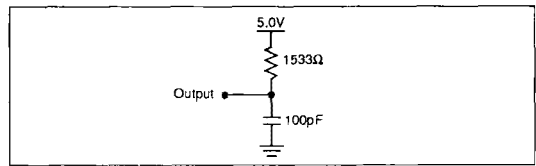

## A.C. CHARACTERISTICS (Over recommended operating conditions unless otherwise specified)

### Read & Write Cycle Limits

Symbol	Parameter	Min.	Max.	Units
$f_{SCL}$	SCL Clock Frequency	0	100	KHz
$T_I$	Noise Suppression Time Constant at SCL, SDA Inputs		100	ns
$t_{AA}$	SCL Low to SDA Data Out Valid	0.3	3.5	$\mu$ s
$t_{BUF}$	Time the Bus Must Be Free Before a New Transmission Can Start	4.7		$\mu$ s
$t_{HD:STA}$	Start Condition Hold Time	4.0		$\mu$ s
$t_{LOW}$	Clock Low Period	4.7		$\mu$ s
$t_{HIGH}$	Clock High Period	4.0		$\mu$ s
$t_{SU:STA}$	Start Condition Setup Time (for a Repeated Start Condition)	4.7		$\mu$ s
$t_{HD:DAT}$	Data In Hold Time	0		$\mu$ s
$t_{SU:DAT}$	Data In Setup Time	250		ns
$t_R$	SDA and SCL Rise Time		1	$\mu$ s
$t_F$	SDA and SCL Fall Time		300	ns
$t_{SU:STO}$	Stop Condition Setup Time	4.7		$\mu$ s
$t_{DH}$	Data Out Hold Time	300		ns

3839 PGM T06

## POWER-UP TIMING

Symbol	Parameter	Max.	Units
$t_{PUR}^{(4)}$	Power-up to Read Operation	1	ms
$t_{PUW}^{(4)}$	Power-up to Write Operation	5	ms

3839 PGM T07

## Bus Timing

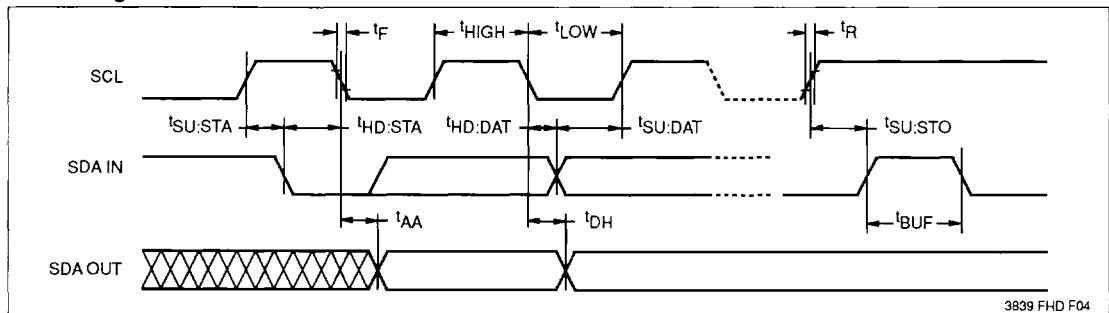

3839 FHD F04

**Notes:** (4)  $t_{PUR}$  and  $t_{PUW}$  are the delays required from the time  $V_{CC}$  is stable until the specified operation can be initiated. These parameters are periodically sampled and not 100% tested.

# X24C04

## Write Cycle Limits

Symbol	Parameter	Min.	Typ. <sup>(5)</sup>	Max.	Units
$t_{WR}^{(6)}$	Write Cycle Time		5	10	ms

3839 PGM T08

The write cycle time is the time from a valid stop condition of a write sequence to the end of the internal erase/program cycle. During the write cycle, the X24C04

bus interface circuits are disabled, SDA is allowed to remain high, and the device does not respond to its slave address.

## Write Cycle Timing

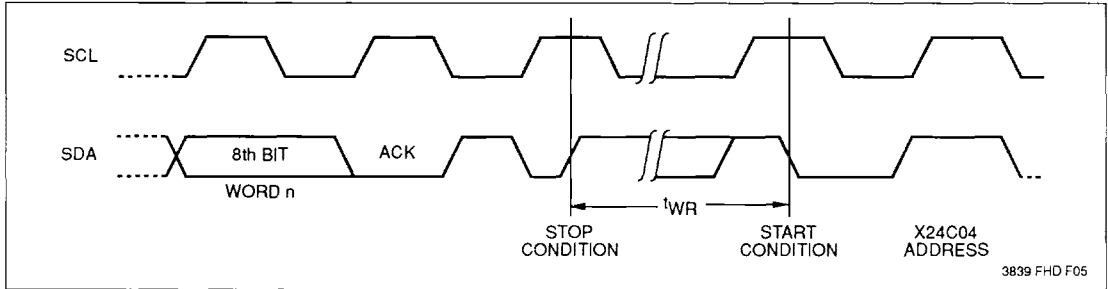

**Notes:** (5) Typical values are for  $T_A = 25^\circ\text{C}$  and nominal supply voltage (5V).

(6)  $t_{WR}$  is the minimum cycle time from the system perspective when polling techniques are not used. It is the maximum time the device requires to perform the internal write operation.

## Guidelines for Calculating Typical Values of Bus Pull-Up Resistors

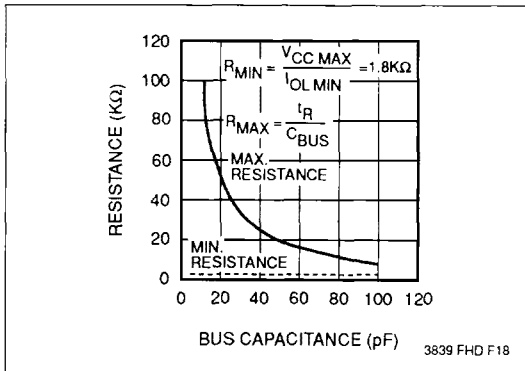

## SYMBOL TABLE

WAVEFORM	INPUTS	OUTPUTS
	Must be steady	Will be steady
	May change from Low to High	Will change from Low to High
	May change from High to Low	Will change from High to Low
	Don't Care: Changes Allowed	Changing: State Not Known
	N/A	Center Line is High Impedance

2

**X24C04**

---

**NOTES**