

## Features

- 10 ns pin-to-pin logic delays on all pins
- $f_{CNT}$  to 111 MHz
- 216 macrocells with 4800 usable gates
- Up to 166 user I/O pins
- 5 V in-system programmable
  - Endurance of 10,000 program/erase cycles
  - Program/erase over full commercial voltage and temperature range
- Enhanced pin-locking architecture
- Flexible 36V18 Function Block
  - 90 product terms drive any or all of 18 macrocells within Function Block
  - Global and product term clocks, output enables, set and reset signals
- Extensive IEEE Std 1149.1 boundary-scan (JTAG) support
- Programmable power reduction mode in each macrocell
- Slew rate control on individual outputs
- User programmable ground pin capability
- Extended pattern security features for design protection
- High-drive 24 mA outputs
- 3.3 V or 5 V I/O capability
- PCI compliant (-10 speed grade)
- Advanced CMOS 5V FastFLASH technology
- Supports parallel programming of more than one XC9500 concurrently
- Available in 160-pin PQFP, 352-pin BGA, and 208-pin HQFP packages

## Description

The XC95216 is a high-performance CPLD providing advanced in-system programming and test capabilities for general purpose logic integration. It is comprised of twelve 36V18 Function Blocks, providing 4,800 usable gates with propagation delays of 10 ns. See Figure 2 for the architecture overview.

## Power Management

Power dissipation can be reduced in the XC95216 by configuring macrocells to standard or low-power modes of operation. Unused macrocells are turned off to minimize power dissipation.

Operating current for each design can be approximated for specific operating conditions using the following equation:

$$I_{CC} \text{ (mA)} = MC_{HP} (1.7) + MC_{LP} (0.9) + MC (0.006 \text{ mA/MHz}) f$$

Where:

$MC_{HP}$  = Macrocells in high-performance mode

$MC_{LP}$  = Macrocells in low-power mode

$MC$  = Total number of macrocells used

$f$  = Clock frequency (MHz)

Figure 1 shows a typical calculation for the XC95216 device.

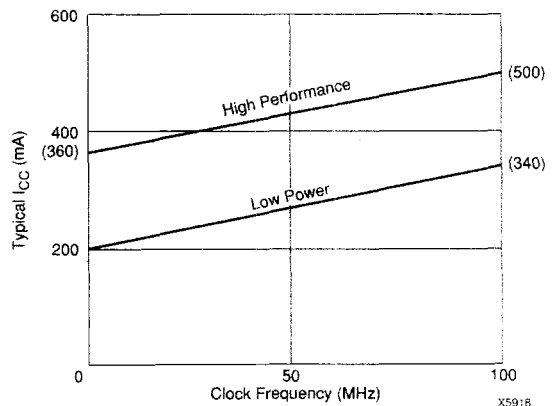
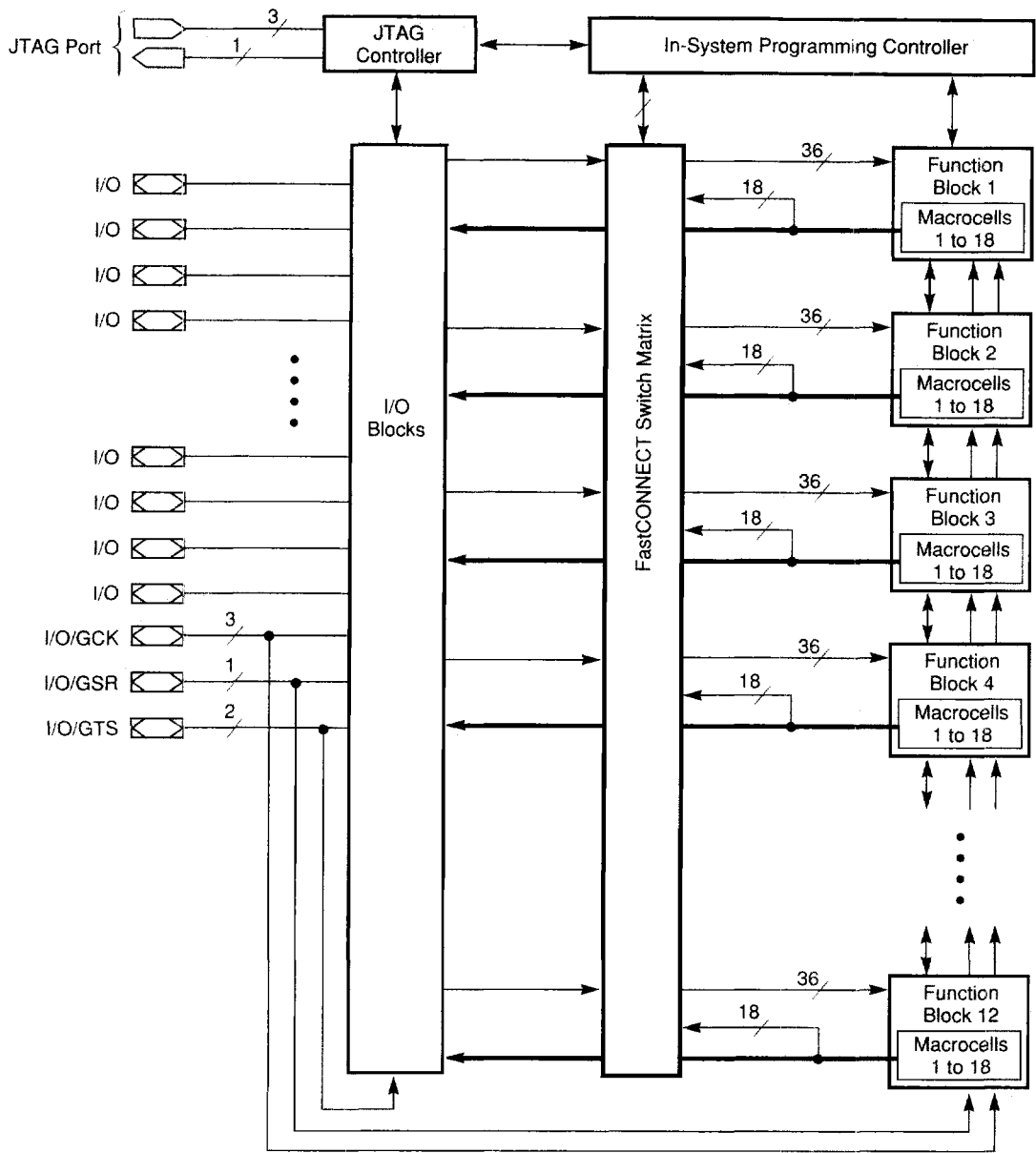

Figure 1: Typical  $I_{CC}$  vs. Frequency For XC95216



X5917

**Figure 2: XC95216 Architecture**

Function Block outputs (indicated by the bold line) drive the I/O Blocks directly

## Absolute Maximum Ratings

Symbol	Parameter	Value	Units
$V_{CC}$	Supply voltage relative to GND	-0.5 to 7.0	V
$V_{IN}$	DC input voltage relative to GND	-0.5 to $V_{CC} + 0.5$	V
$V_{TS}$	Voltage applied to 3-state output with respect to GND	-0.5 to $V_{CC} + 0.5$	V
$T_{STG}$	Storage temperature	-65 to +150	°C
$T_{SOL}$	Max soldering temperature (10 s @ 1/16 in = 1.5 mm)	+260	°C

**Warning:** Stresses beyond those listed under Absolute Maximum Ratings may cause permanent damage to the device. These are stress ratings only, and functional operation of the device at these or any other conditions beyond those listed under Recommended Operating Conditions is not implied. Exposure to Absolute Maximum Rating conditions for extended periods of time may affect device reliability.

## Recommended Operating Conditions<sup>1</sup>

Symbol	Parameter	Min	Max	Units
$V_{CCINT}$	Supply voltage for internal logic and input buffer	4.75 (4.5)	5.25 (5.5)	V
$V_{CCIO}$	Supply voltage for output drivers for 5 V operation	4.75 (4.5)	5.25 (5.5)	V
	Supply voltage for output drivers for 3.3 V operation	3.0	3.6	V
$V_{IL}$	Low-level input voltage	0	0.80	V
$V_{IH}$	High-level input voltage	2.0	$V_{CCINT} + 0.5$	V
$V_O$	Output voltage	0	$V_{CCIO}$	V

**Note:** 1. Numbers in parenthesis are for industrial-temperature range versions.

## Endurance Characteristics

Symbol	Parameter	Min	Max	Units
$t_{DR}$	Data Retention	20	-	Years
$N_{PE}$	Program/Erase Cycles	10,000	-	Cycles

## DC Characteristics Over Recommended Operating Conditions

Symbol	Parameter	Test Conditions	Min	Max	Units
V <sub>OH</sub>	Output high voltage for 5 V operation	I <sub>OH</sub> = -4.0 mA V <sub>CC</sub> = Min	2.4		V
	Output high voltage for 3.3 V operation	I <sub>OH</sub> = -3.2 mA V <sub>CC</sub> = Min	2.4		V
V <sub>OL</sub>	Output low voltage for 5 V operation	I <sub>OL</sub> = 24 mA V <sub>CC</sub> = Min		0.5	V
	Output low voltage for 3.3 V operation	I <sub>OL</sub> = 10 mA V <sub>CC</sub> = Min		0.4	V
I <sub>IL</sub>	Input leakage current	V <sub>CC</sub> = Max V <sub>IN</sub> = GND or V <sub>CC</sub>		±10.0	μA
I <sub>IH</sub>	I/O high-Z leakage current	V <sub>CC</sub> = Max V <sub>IN</sub> = GND or V <sub>CC</sub>		±10.0	μA
C <sub>IN</sub>	I/O capacitance	V <sub>IN</sub> = GND f = 1.0 MHz		10.0	pF
I <sub>CC</sub>	Operating Supply Current (low power mode, active)	V <sub>I</sub> = GND, No load f = 1.0 MHz	200 (typ)		ma

## AC Characteristics

Symbol	Parameter	XC95216-10		XC95216-15		XC95216-20		Units
		Min	Max	Min	Max	Min	Max	
t <sub>PD</sub>	I/O to output valid		10.0		15.0		20.0	ns
t <sub>SU</sub>	I/O setup time before GCK	6.5		8.0		10.0		ns
t <sub>H</sub>	I/O hold time after GCK	0.0		0.0		0.0		ns
t <sub>CO</sub>	GCK to output valid		6.5		8.0		10.0	ns
f <sub>CNT</sub> <sup>1</sup>	16-bit counter frequency	111		95		83		MHz
f <sub>SYSTEM</sub> <sup>2</sup>	Multiple FB internal operating frequency	67		56		50		MHz
t <sub>PSU</sub>	I/O setup time before p-term clock input	2.5		4.0		4.0		ns
t <sub>PH</sub>	I/O hold time after p-term clock input	4.0		4.0		6.0		ns
t <sub>PCO</sub>	P-term clock to output valid		10.5		12.0		16.0	ns
t <sub>OE</sub>	GTS to output valid		10.0		15.0		20.0	ns
t <sub>OD</sub>	GTS to output disable		10.0		15.0		20.0	ns
t <sub>POE</sub>	Product term OE to output enabled		15.5		18.0		22.0	ns
t <sub>POD</sub>	Product term OE to output disabled		15.5		18.0		22.0	ns
t <sub>WLH</sub>	GCK pulse width (High or Low)		4.5		5.5		5.5	ns

- Note:**
- f<sub>CNT</sub> is the fastest 16-bit counter frequency available, using the local feedback when applicable. f<sub>CNT</sub> is also the Export Control Maximum flip-flop toggle rate, f<sub>TOG</sub>.
  - f<sub>SYSTEM</sub> is the internal operating frequency for general purpose system designs spanning multiple FBs.

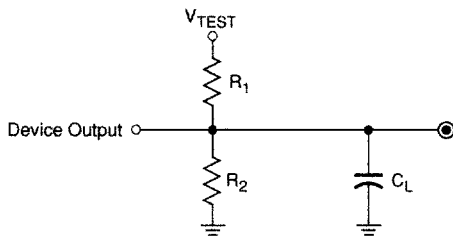

Output Type	V <sub>CCIO</sub>	V <sub>TEST</sub>	R <sub>1</sub>	R <sub>2</sub>	C <sub>L</sub>
	5.0 V	5.0 V	160 Ω	120 Ω	35 pF
	3.3 V	3.3 V	260 Ω	360 Ω	35 pF

X5906

Figure 3: AC Load Circuit

## Internal Timing Parameters

Symbol	Parameter	XC95216-10		XC95216-15		XC95216-20		Units
		Min	Max	Min	Max	Min	Max	
<b>Buffer Delays</b>								
t <sub>IN</sub>	Input buffer delay		3.5		4.5		6.5	ns
t <sub>GCK</sub>	GCK buffer delay		3.0		3.0		3.0	ns
t <sub>GSR</sub>	GSR buffer delay		6.0		7.5		9.5	ns
t <sub>GTS</sub>	GTS buffer delay		10.0		15.0		20.0	ns
t <sub>OUT</sub>	Output buffer delay		3.0		4.5		6.5	ns
t <sub>EN</sub>	Output buffer enable/disable delay		0.0		0.0		0.0	ns
<b>Product Term Control Delays</b>								
t <sub>PTCK</sub>	Product term clock delay		3.5		2.5		2.5	ns
t <sub>PTSR</sub>	Product term set/reset delay		2.5		3.0		3.0	ns
t <sub>PTTS</sub>	Product term 3-state delay		12.0		13.5		15.5	ns
<b>Internal Register and Combinatorial delays</b>								
t <sub>PDI</sub>	Combinatorial logic propagation delay		1.0		3.0		4.0	ns
t <sub>SUI</sub>	Register setup time	3.5		3.5		3.5		ns
t <sub>HI</sub>	Register hold time	3.0		4.5		6.5		ns
t <sub>COI</sub>	Register clock to output valid time		0.5		0.5		0.5	ns
t <sub>AOI</sub>	Register async. S/R to output delay		7.0		8.0		9.0	ns
t <sub>RAI</sub>	Register async. S/R recovery before clock	10.0		15.0		20.0		ns
t <sub>LOGI</sub>	Internal logic delay		2.5		3.0		3.0	ns
t <sub>LOGILP</sub>	Internal low power logic delay		11.0		11.5		11.5	ns
<b>Feedback Delays</b>								
t <sub>F</sub>	FastCONNECT matrix feedback delay		8.5		11.0		13.0	ns
t <sub>LF</sub>	Function Block local feedback delay		2.5		3.5		5.0	ns
<b>Time Adders</b>								
t <sub>PTA</sub> <sup>3</sup>	Incremental Product Term Allocator delay		1.0		1.5		1.5	ns
t <sub>SLEW</sub>	Slew-rate limited delay		4.5		5.0		5.5	ns

**Note:** 3. t<sub>PTA</sub> is multiplied by the span of the function as defined in the family data sheet.

## XC95216 I/O Pins

Function Block	Macrocell	PQ160	HQ208	BG352	BScan Order	Notes	Function Block	Macrocell	PQ160	HQ208	BG352	BScan Order	Notes
1	1	--	--	--	645		3	1	--	--	--	537	
1	2	18	22	M25	642		3	2	32	43	AA26	534	
1	3	19	23	M26	639		3	3	33	44	Y24	531	[1]
1	4	--	28	N26	636		3	4	--	39	U23	528	
1	5	21	25	N25	633		3	5	34	45	AB25	525	
1	6	22	30	P23	630		3	6	35	46	AA24	522	[1]
1	7	--	--	--	627		3	7	--	--	--	519	
1	8	23	31	P24	624		3	8	36	47	Y23	516	
1	9	24	32	R26	621		3	9	37	49	AA23	513	
1	10	--	12	G26	618		3	10	--	67	AD18	510	
1	11	25	33	R24	615		3	11	38	50	AB24	507	
1	12	26	34	T26	612		3	12	39	51	AD25	504	
1	13	--	--	--	609		3	13	--	--	--	501	
1	14	27	35	T25	606		3	14	42	55	AD23	498	[1]
1	15	28	36	T23	603		3	15	43	56	AF24	495	
1	16	29	37	V26	600		3	16	--	80	AE12	492	
1	17	30	38	U24	597		3	17	44	57	AE23	489	
1	18	--	--	--	594		3	18	--	--	--	486	
2	1	--	--	--	591		4	1	--	--	--	483	
2	2	6	7	E25	588	[1]	4	2	152	198	D18	480	
2	3	7	8	G24	585		4	3	153	199	A21	477	
2	4	--	29	P25	582		4	4	--	196	B19	474	
2	5	8	9	F26	579	[1]	4	5	154	200	B20	471	
2	6	9	10	H23	576		4	6	155	201	C20	468	
2	7	--	--	--	573		4	7	--	--	--	465	
2	8	11	15	K23	570		4	8	156	202	B22	462	
2	9	12	16	K24	567		4	9	158	205	B24	459	
2	10	--	--	--	564		4	10	--	--	--	456	
2	11	13	17	J25	561		4	11	159	206	C23	453	[1]
2	12	14	18	L24	558		4	12	2	3	E23	450	[1]
2	13	--	--	--	555		4	13	--	--	--	447	
2	14	15	19	K25	552		4	14	3	4	C26	444	
2	15	16	20	L26	549		4	15	4	5	E24	441	[1]
2	16	--	14	H25	546		4	16	--	203	D20	438	
2	17	17	21	M24	543		4	17	5	6	F24	435	
2	18	--	--	--	540		4	18	--	--	--	432	

**XC95216 I/O Pins (continued)**

Function Block	Macrocell	PQ160	HQ208	BG352	BScan Order	Notes	Function Block	Macrocell	PQ160	HQ208	BG352	BScan Order	Notes
5	1	--	--	--	429		7	1	--	--	--	321	
5	2	45	58	AE22	426		7	2	58	76	AE13	318	
5	3	47	60	AE21	423		7	3	59	77	AC13	315	
5	4	--	41	W25	420		7	4	--	54	AE24	312	
5	5	48	61	AF21	417		7	5	60	78	AD13	309	
5	6	49	63	AD19	414		7	6	62	82	AD12	306	
5	7	--	--	--	411		7	7	--	--	--	303	
5	8	50	64	AE20	408		7	8	63	83	AC12	300	
5	9	52	70	AF18	405		7	9	64	84	AF11	297	
5	10	--	109	AD1	402		7	10	--	91	AD8	294	
5	11	53	71	AE17	399		7	11	65	85	AE11	291	
5	12	54	72	AE16	396		7	12	66	86	AE9	288	
5	13	--	--	--	393		7	13	--	--	--	285	
5	14	55	73	AF16	390		7	14	67	87	AD9	282	
5	15	56	74	AE14	387		7	15	68	88	AC10	279	
5	16	--	40	Y26	384		7	16	--	48	AC26	276	
5	17	57	75	AF14	381		7	17	69	89	AF7	273	
5	18	--	--	--	378		7	18	--	--	--	270	
6	1	--	--	--	375		8	1	--	--	--	267	
6	2	140	180	A12	372		8	2	126	162	B5	264	
6	3	142	182	A13	369		8	3	128	164	B6	261	
6	4	--	208	D22	366		8	4	--	143	J1	258	
6	5	143	185	C14	363		8	5	129	166	D8	255	
6	6	144	186	A15	360		8	6	130	167	B7	252	
6	7	--	--	--	357		8	7	--	--	--	249	
6	8	145	187	B15	354		8	8	131	170	C10	246	
6	9	146	188	C15	351		8	9	132	171	B9	243	
6	10	--	183	B14	348		8	10	--	195	A20	240	
6	11	147	191	A16	345		8	11	133	173	A9	237	
6	12	148	192	C16	342		8	12	134	174	D11	234	
6	13	--	--	--	339		8	13	--	--	--	231	
6	14	149	193	C17	336		8	14	135	175	B11	228	
6	15	150	194	B18	333		8	15	138	178	C12	225	
6	16	--	169	D9	330		8	16	--	189	D15	222	
6	17	151	197	C19	327		8	17	139	179	B12	219	
6	18	--	--	--	324		8	18	--	--	--	216	

## XC95216 I/O Pins (continued)

Function Block	Macrocell	PQ160	HQ208	BG352	BScan Order	Notes	Function Block	Macrocell	PQ160	HQ208	BG352	BScan Order	Notes
9	1	--	--	--	213		11	1	--	--	--	105	
9	2	72	95	AD7	210		11	2	87	115	Y1	102	
9	3	74	97	AE5	207		11	3	88	116	V4	99	
9	4	--	101	AD4	204		11	4	--	119	U4	96	
9	5	76	99	AC7	201		11	5	89	117	V3	93	
9	6	77	100	AE3	198		11	6	90	118	W2	90	
9	7	--	--	--	195		11	7	--	--	--	87	
9	8	78	102	AC5	192		11	8	91	121	V2	84	
9	9	79	103	AD3	189		11	9	92	122	U2	81	
9	10	--	90	AE8	186		11	10	--	107	AC3	78	
9	11	82	110	AA4	183		11	11	93	123	T2	75	
9	12	83	111	AB2	180		11	12	95	125	R4	72	
9	13	--	--	--	177		11	13	--	--	--	69	
9	14	84	112	AC1	174		11	14	96	126	R3	66	
9	15	85	113	AA2	171		11	15	97	127	R2	63	
9	16	--	62	AC19	168		11	16	--	120	U3	60	
9	17	86	114	AA1	165		11	17	98	128	R1	57	
9	18	--	--	--	162		11	18	--	--	--	54	
10	1	--	--	--	159		12	1	--	--	--	51	
10	2	113	147	H3	156		12	2	101	131	P1	48	
10	3	114	148	J4	153		12	3	102	133	N2	45	
10	4	--	144	K3	150		12	4	--	106	AD2	42	
10	5	115	149	G2	147		12	5	103	134	N4	39	
10	6	116	150	G3	144		12	6	104	135	N3	36	
10	7	--	--	--	141		12	7	--	--	--	33	
10	8	117	152	E2	138		12	8	105	136	M1	30	
10	9	118	154	D2	135		12	9	106	137	M3	27	
10	10	--	168	A7	132		12	10	--	151	F2	24	
10	11	119	155	F4	129		12	11	107	138	M4	21	
10	12	122	158	B3	126		12	12	108	139	L1	18	
10	13	--	--	--	123		12	13	--	--	--	15	
10	14	123	159	A3	120		12	14	109	140	L2	12	
10	15	124	160	D6	117		12	15	111	145	G1	9	
10	16	--	165	A6	114		12	16	--	142	L3	6	
10	17	125	161	C6	111		12	17	112	146	H2	3	
10	18	--	--	--	108		12	18	--	--	--	0	



## XC95216 Global, JTAG and Power Pins

Pin Type	PQ160	HQ208	BG352
I/O/GCK1	33	44	Y24
I/O/GCK2	35	46	AA24
I/O/GCK3	42	55	AD23
I/O/GTS1	6	7	E25
I/O/GTS2	8	9	F26
I/O/GTS3	2	3	E23
I/O/GTS4	4	5	E24
I/O/GSR	159	206	C23
TCK	75	98	AD6
TDI	71	94	AF6
TDO	136	176	D12
TMS	73	96	AE6
V <sub>CCINT</sub> 5 V	10,46,94,157	11, 59, 124, 153, 204	H24, AF23, T1, G4, C22
V <sub>CCIO</sub> 3.3 V/5 V	1,41,61,81,121,141	1, 26, 53, 65, 79, 92, 105, 132, 157, 172, 181, 184	A10, A17, B2, B25, D7, D13, D19, G23, H4, K1, K26, N23, P4, U1, U26, W23, Y4, AC8, AC14, AC20, AE25, AF10, AF17
GND	20, 31, 40, 51, 70, 80, 99, 100, 110, 120, 127, 137, 160	2, 13, 24, 27, 42, 52, 66, 68, 69, 81, 93, 104, 108, 129, 130, 141, 156, 163, 177, 190, 207	A1, A2, A5, A8, A14, A19, A22, A25, A26, B1, B26, C7, E1, E26, H1, H26, N1, P3, P26, V23, W1, W26, AB1, AB4, AB26, AC9, AC17, AE1, AE26, AF1, AF2, AF5, AF8, AF13, AF19, AF20, AF22, AF25, AF26
No Connects	—	—	A4, A11, A18, A23, A24, B4, B8, B10, B13, B16, B17, B21, B23, C1, C2, C3, C4, C5, C8, C9, C11, C13, C18, C21, C24, C25, D1, D3, D4, D5, D10, D14, D16, D17, D21, D23, D24, D25, D26, E3, E4, F1, F3, F23, F25, G25, J2, J3, J23, J24, J26, K2, K4, L4, L23, L25, M2, M23, N24, P2, R23, R25, T3, T4, T24, U25, V1, V24, V25, W3, W4, W24, Y2, Y3, Y25, AA3, AA25, AB3, AB23, AC2, AC4, AC6, AC11, AC15, AC16, AC18, AC21, AC22, AC23, AC24, AC25, AD5, AD10, AD11, AD14, AD15, AD16, AD17, AD20, AD21, AD22, AD24, AD26, AE2, AE4, AE7, AE10, AE15, AE18, AE19, AF3, AF4, AF9, AF12, AF15

## Ordering Information

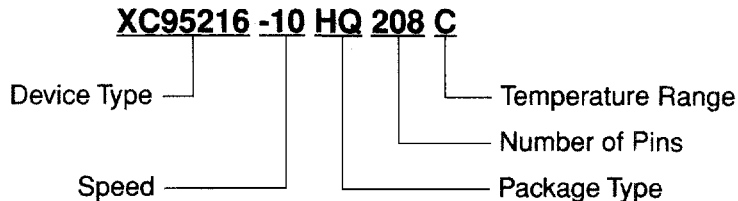

### Speed Options

- 20 20 ns pin-to-pin delay
- 15 15 ns pin-to-pin delay
- 10 10 ns pin-to-pin delay

### Packaging Options

- PQ160 160-Pin Plastic Quad Flat Pack (PQFP)
- HQ208 208-Pin Heat Sink Quad Flat Pack (HQFP)
- BG352 352-Pin Ball Grid Array (BGA)

### Temperature Options

- C Commercial 0°C to 70°C
- I Industrial -40°C to 85°C

## Component Availability

Pins		160	160	352
Type		Plastic PQFP	Power QFP	Plastic BGA
Code		PQ160	HQ208	BG352
XC95216	-20	C,I	C,I	C,I
	-15	C	C	C,I
	-10	C	C	C

C = Commercial = 0° to +70°C    I = Industrial = -40° to 85°C