

CATALOG NUMBER	CONDUCTOR RANGE								DIMENSIONS			INSTALLATION TOOLING		WIRE STRIP LENGTH	REV.	DATE	DESCRIPTION	BY	C'K'D.				
	CABLE				SOLID WIRE				L ±.05	O.D. ±.01	WALL ±.008	COLOR CODE	DIE INDEX							HYTOOL™		HYPRESS™	
	SQ. IN. MIN.	AREA MAX.	CIRCULAR MILS MIN.	MAX.	SQ. IN. MIN.	AREA MAX.	CIRCULAR MILS MIN.	MAX.												RATCHET	MECHANICAL	Y29B NEST	INDENTOR
YSM18	.0002	.0013	300	1,909	.0008	.0020	1,022	2,540	.25 [6]	.12 [3]	.036 [1]									5/16"			
YSM14G1	.0004	.0032	477	4,107	.0020	.0055	2,540	7,001	.15 [4]	.16 [4]	.035 [1]			Y14MRQ						1/4"			
YSM14	.0004	.0032	477	4,107	.0020	.0055	2,540	7,001	.25 [6]	.16 [4]	.035 [1]			MR8-9Q						5/16"			
YSM10G7	.0032	.0082	4,107	10,380	.0055	.0123	7,001	15,658	.34 [9]	.21 [5]	.041 [1]			Y10MRQ						7/16"			
YSM10	.0032	.0082	4,107	10,380	.0055	.0123	7,001	15,658	.36 [9]	.21 [5]	.041 [1]			MR8-9Q MR4CQ						7/16"			
YSM9CG1	.0082	.0103	10,380	13,090					.44 [11]	.23 [6]	.039 [1]			Y8MRB-1 MR8-9Q MR4CQ						1/2"			
YSM8C	.0048	.0132	6,088	16,864	.0123	.0229	15,658	29,139	.41 [10]	.27 [7]	.045 [1]			MR8-9Q MR4CQ Y2MR	DV8L-1		UV8L-1			1/2"			
YSM8CG3	.0048	.0132	6,088	16,864	.0123	.0229	15,658	29,139	.75 [19]	.27 [7]	.045 [1]	RED	49		DV8L-1		UV8L-1			13/16"			
YSM6C	.0082	.0211	10,380	26,813	.0229	.0361	29,139	45,955	.44 [11]	.31 [8]	.044 [1]			MR4CQ Y2MR	DV6L		UV6L			1/2"			
YSM6CG6	.0082	.0211	10,380	26,813	.0229	.0361	29,139	45,955	.75 [19]	.31 [8]	.044 [1]	BLUE	7		DV6L	Y29PQ	UV6L	Y29PQ		13/16"			
YSM4C	.0211	.0335	26,813	42,613	.0361	.0473	45,955	61,000	.50 [13]	.38 [10]	.046 [1]	GRAY	8		MR4CQ Y2MR	DV4L		UV4L		9/16"			
YSM2C	.0335	.0497	42,613	66,832	.0473	.0824	61,000	105,000	.62 [16]	.47 [12]	.052 [1]	BROWN	10	MY29-11 OR MY28 1 CRIMP	DV2L		UV2L			11/16"			
YSM1C	.0497	.0632	66,832	81,807	.0824	.1075	105,000	137,000	.62 [16]	.52 [13]	.060 [2]				DV1L		UV1L			11/16"			
YSM25	.0632	.0811	81,807	104,110	.1075	.1244	137,000	157,000	.69 [18]	.57 [14]	.060 [2]				DV25L		UV25L			3/4"			
YSM26	.0811	.1042	104,110	133,650	.1244	.1590	157,000	197,000	.81 [21]	.64 [16]	.065 [2]				DV26L	Y29PQ-6	UV26L	Y29PQ-6		7/8"			
YSM27	.1042	.1304	133,650	167,332	.1590	.1963	197,000	250,000	.81 [21]	.70 [18]	.069 [2]				DV27L		UV27L			7/8"			
YSM28	.1304	.1650	167,332	211,954	.1963	.2356	250,000	300,000	.88 [22]	.78 [20]	.073 [2]				DV28L		UV28L			15/16"			

TABLE 2

CATALOG NUMBER	CONDUCTOR RANGE		DIMENSIONS			HYTOOL™	TOOL SETTING	WIRE STRIP LENGTH
	STRANDED COPPER WIRE		L ±.05	O.D. ±.01	WALL ±.008			
	QUANTITY	SIZE						
YSM2C	5	#10 AWG	.62	.46	.052	MY-28	COPPER AIRCRAFT CABLE #4 - #2 (1 CRIMP)	11/16"
	6							
	7							
	8							
	9							
YSM4C	3	#10 AWG	.50	.38	.046	MY-28	COPPER AIRCRAFT CABLE #8 - #6 (1 CRIMP)	9/16"
	4							
	5							
	6							
	2							
YSM6C	3	#12 AWG	.44	.31	.044	MY-28	COPPER AIRCRAFT CABLE #8 - #6 (1 CRIMP)	1/2"
	4							
	5							
	4							
	6							

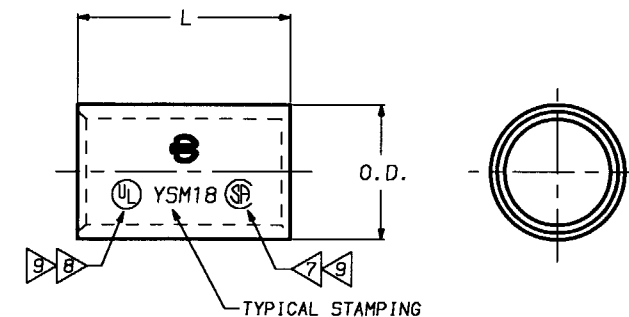
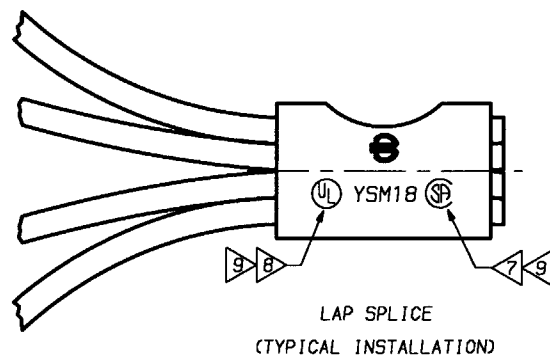

NOTES:

- MATERIAL: COPPER
- FINISH: TIN PLATED
- MR8-9Q CAN BE USED IF STOP PLATE IS REMOVED.
- INDENTORS USED WITH THE Y35 AND Y35BH HYPRESS™ TOOLS ARE HELD WITH THE Y35P ADAPTOR.
- FOR ADDITIONAL INSTALLATION TOOLING REFER TO FACTORY.
- DIMENSIONS IN BRACKETS [] ARE IN MILLIMETERS ROUNDED OFF TO THE NEAREST MILLIMETER, UNLESS OTHERWISE NOTED, AND ARE FOR REFERENCE ONLY.
- ALL STANDARD CATALOG NUMBERS ARE CSA APPROVED (SEE TABLE 1 FOR EXCEPTIONS).
- YSM6C, YSM4C AND YSM2C ARE UL LISTED SEE TABLE 2 FOR TOOLING AND LISTED COMBINATIONS.
- THESE CONNECTORS (SEE TABLE 1) ARE NOT UL OR CSA APPROVED.

PARALLEL HYLINK™			
CAT NO: YSM-	(TABLE)	SCALE	NTS
DRAWN: H.E.B.	10/9/58	CHECKED: C.R.S.	10/10/58
DSGN APPVL: K WOO	4/25/96	MFG APPVL: N/A	
Q.A. APPVL: J BRODEUR	4/25/96	MKTG APPVL: G SCHWEBLER	4/29/96
CAD FILE: SC41139-01_11		PH REF: N/A	
FRAMATOME CONNECTORS USA INC.		DRAWING NO.	
BURNDY ELECTRICAL		REV	
MANCHESTER, NH 03108		SC41139	
U.S.A.		11	
1-800-346-4175		SHEET 1 OF 2	

REV. 061958