



# ZN447/ZN448/ZN449

T-51-10-08

## 8-BIT MICROPROCESSOR COMPATIBLE A-D CONVERTERS

The ZN447, ZN448 and ZN449 are 8-bit, successive approximation A-D converters designed for easy interfacing to microprocessors. All active circuitry is contained on-chip including a clock generator and stable 2.5V bandgap reference.

Only a reference resistor and capacitor, clock resistor and capacitor and input resistors are required for operation with either unipolar or bipolar input voltage.

### FEATURES

- Easy Interfacing to Microprocessor, or operates as a 'Stand-Alone' Converter
- Fast: 9 microseconds Conversion time Guaranteed
- Choice of Linearity: 0.3 LSB — ZN447, 0.5 LSB — ZN448, 1 LSB — ZN449
- On-Chip Clock
- Choice of On-Chip or External Reference Voltage
- Unipolar or Bipolar Input Ranges
- Commercial or Military Temperature Ranges

### ORDERING INFORMATION

Device type	Linearity error (LSB)	Operating temperature	Package
ZN447D	0.3	0°C to +70°C	MP18
ZN447E	0.3	0°C to +70°C	DP18
ZN447J	0.3	-55°C to +125°C	DC18
ZN448D	0.5	0°C to +70°C	MP18
ZN448E	0.5	0°C to +70°C	DP18
ZN448J	0.5	-55°C to +125°C	DC18
ZN449D	1.0	0°C to +70°C	MP18
ZN449E	1.0	0°C to +70°C	DP18
ZN449J	1.0	-55°C to +125°C	DC18

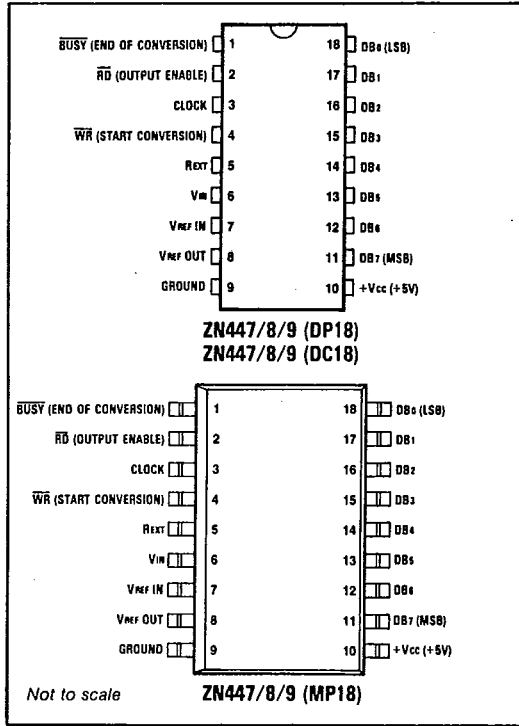

Pin connections - top view

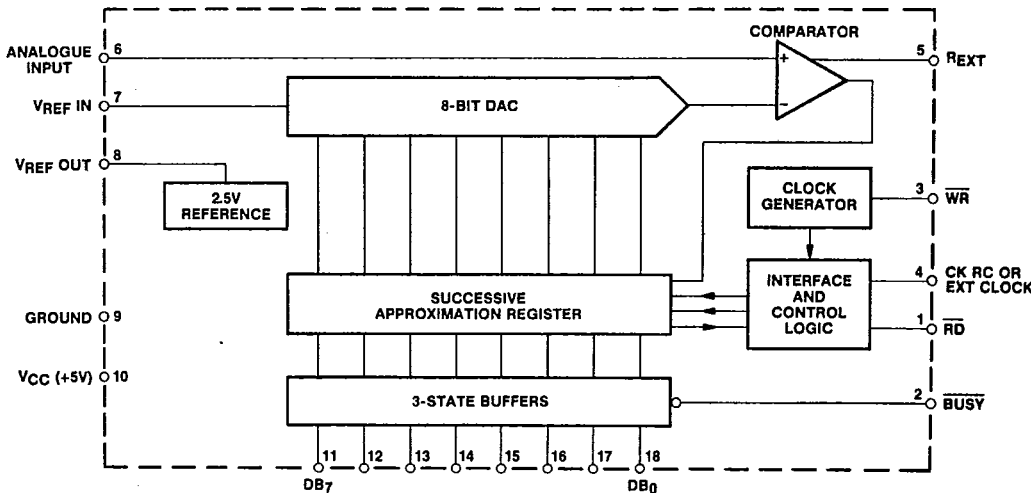

Fig.1 System diagram

T-51-10-08

**ABSOLUTE MAXIMUM RATINGS**

Supply voltage  $V_{CC}$  +7V  
 Max. voltage, logic and  $V_{REF}$  inputs + $V_{CC}$   
 Operating temperature range 0°C to +70°C (MP and DP packages)  
 -55°C to +125°C (DC package)  
 Storage temperature range -55°C to +125°C

**ELECTRICAL CHARACTERISTICS** ( $V_{CC} = +5V$ ,  $T_{amb} = 25^\circ C$ ,  $f_{CLK} = 900kHz$ , unless otherwise specified).

Parameter	Min.	Typ.	Max.	Units	Conditions
<b>ZN447</b>					
Linearity error	-	-	±0.3	LSB	
Differential linearity error	-	-	±0.5	LSB	
Zero transition (00000000→00000001)	10.5	12	13.5	mV	MP package
	13.5	15	16.5	mV	DP package
	15	16.5	18	mV	DC package
Full-scale transition (11111110→11111111)	2.548	2.550	2.552	V	$V_{REF} = 2.560V$
<b>ZN448</b>					
Linearity error	-	-	±0.5	LSB	
Differential linearity error	-	-	±0.75	LSB	
Zero transition (00000000→00000001)	9	12	15	mV	MP package
	12	15	18	mV	DP package
	13	16.5	20	mV	DC package
Full-scale transition (11111110→11111111)	2.545	2.550	2.555	V	$V_{REF} = 2.560V$
<b>ZN449</b>					
Linearity error	-	-	±1	LSB	
Differential linearity error	-	-	±1	LSB	
Zero transition (00000000→00000001)	7	12	17	mV	MP package
	10	15	20	mV	DP package
	11.5	16.5	21.5	mV	DC package
Full-scale transition (00000000→11111111)	2.542	2.550	2.558	V	$V_{REF} = 2.560V$
<b>All types</b>					
Resolution	8	-	-	bits	
Linearity temperature coefficient	-	±3	-	ppm/°C	
Differential linearity temperature coefficient	-	±6	-	ppm/°C	
Full-scale temperature coefficient	-	±2.5	-	ppm/°C	
Zero temperature coefficient	-	±8	-	µV/°C	
Reference input range	1	-	3	V	
Supply voltage	4.5	5	5.5	V	
Supply current	-	25	40	mA	
Power consumption	-	125	200	mW	

T-51-10-08

## ELECTRICAL CHARACTERISTICS (Cont.)

Parameter	Min.	Typ.	Max.	Units	Conditions
<b>Comparator</b>					
Input current	-	1	-	$\mu\text{A}$	$V_{\text{IN}} = +3\text{V}$ , $R_{\text{EXT}} = 82\text{k}\Omega$
Input resistance	-	100	-	$\text{k}\Omega$	
Tail current	25	65	150	$\mu\text{A}$	$V_- = -5\text{V}$
Negative supply	-3	-5	-30	V	
Input voltage	-0.5	-	+3.5	V	
<b>On-chip reference</b>					
Output voltage ZN447	2.520	2.550	2.580		$R_{\text{REF}} = 390\Omega$
ZN448	2.520	2.550	2.580	V	
ZN449	2.500	2.550	2.600		$C_{\text{REF}} = 4\mu\text{F}$
Slope resistance	-	0.5	2	$\Omega$	
$V_{\text{REF}}$ temperature coefficient	-	50	-	ppm/ $^{\circ}\text{C}$	
Reference current	4	-	15	mA	
<b>Clock</b>					
On-chip clock frequency	-	-	1	MHz	
Clock frequency temperature coefficient	-	+0.5	-	%/ $^{\circ}\text{C}$	
Clock resistor	-	-	2	$\text{k}\Omega$	
Maximum external clock frequency	0.9	-	1	MHz	
Clock pulse width	500	-	-	ns	
High level input voltage $V_{\text{IH}}$	4	-	-	V	
Low level input voltage $V_{\text{IL}}$	-	-	0.8	V	
High level input current $I_{\text{IH}}$	-	-	800	$\mu\text{A}$	$V_{\text{IN}} = +4\text{V}$ , $V_{\text{CC}} = \text{MAX}$
Low level input current $I_{\text{IL}}$	-	-	-500	$\mu\text{A}$	$V_{\text{IN}} = +0.8\text{V}$ , $V_{\text{CC}} = \text{MAX}$
<b>Logic (over operating temperature range)</b>					
<b>Convert input</b>					
High level input voltage $V_{\text{IH}}$	2	-	-	V	
Low level input voltage $V_{\text{IL}}$	-	-	0.8	V	
High level input current $I_{\text{IH}}$	-	300	-	$\mu\text{A}$	$V_{\text{IN}} = +2.4\text{V}$ , $V_{\text{CC}} = \text{MAX}$
Low level input current $I_{\text{IL}}$	-	$\pm 10$	-	$\mu\text{A}$	$V_{\text{IN}} = +0.4\text{V}$ , $V_{\text{CC}} = \text{MAX}$
<b><math>\overline{\text{RD}}</math> input</b>					
High level input voltage $V_{\text{IH}}$	2	-	-	V	
Low level input voltage $V_{\text{IL}}$	-	-	0.8	V	
High level input current $I_{\text{IH}}$	-	+150	-	$\mu\text{A}$	$V_{\text{IN}} = +2.4\text{V}$ , $V_{\text{CC}} = \text{MAX}$
Low level input current $I_{\text{IL}}$	-	-300	-	$\mu\text{A}$	$V_{\text{IN}} = +0.4\text{V}$ , $V_{\text{CC}} = \text{MAX}$

ELECTRICAL CHARACTERISTICS (Cont.)

Parameter	Min.	Typ.	Max.	Units	Conditions
High level output voltage $V_{OH}$	2.4	-	-	V	$I_{OH} = \text{MAX}, V_{CC} = \text{MIN}$
Low level output voltage $V_{OL}$	-	-	0.4	V	$I_{OL} = \text{MAX}, V_{CC} = \text{MIN}$
High level output current $I_{OH}$	-	-	-100	$\mu\text{A}$	$V_{OUT} = +2\text{V}$
Low level output current $I_{OL}$	-	-	1.6	mA	
Three-state disable output leakage	-	-	2	$\mu\text{A}$	
Input clamp diode voltage	-	-	-1.5	V	
$\overline{RD}$ input to data output	-	180	250	ns	
Enable/disable delay times $T_{E1}$	180	210	260	ns	
$T_{E0}$	60	80	100	ns	
$T_{D1}$	80	110	140	ns	
$T_{D0}$	60	80	100	ns	
Convert pulse width $t_{WR}$	200	-	-	ns	
$\overline{WR}$ input to $\overline{BUSY}$ output	-	-	250	ns	

GENERAL CIRCUIT OPERATION

The ZN447 utilises the successive approximation technique. Upon receipt of a negative-going pulse at the  $\overline{WR}$  input the  $\overline{BUSY}$  output goes low, the MSB is set to 1 and all other bits are set to 0, which produces an output voltage of  $V_{REF/2}$  from the DAC. This is compared to the input voltage  $V_{IN}$ ; a decision is made on the next negative clock edge to reset the MSB to 0 if  $\frac{V_{REF}}{2} > V_{IN}$  or leave it set to 1 if  $\frac{V_{REF}}{2} < V_{IN}$ . Bit 2 is set to 1 on the same clock edge, producing an output from the DAC of  $\frac{V_{REF}}{4}$  or  $\frac{V_{REF}}{2} + \frac{V_{REF}}{4}$  depending on the state of the MSB. This voltage is compared to  $V_{IN}$  and on the next clock edge a decision is made regarding bit 2, whilst bit 3 is set to 1. This procedure is repeated for all eight bits. On the eighth negative clock edge  $\overline{BUSY}$  goes high indicating that the conversion is complete.

During a conversion the  $\overline{RD}$  input will normally be held high to keep the three-state buffers in their high impedance state. Data can be read out by taking  $\overline{RD}$  low, thus enabling the three-state outputs. Readout is non-destructive.

CONVERSION TIMING

The ZN447 will accept a low-going CONVERT pulse, which can be completely asynchronous with respect to the clock, and will produce valid data between 7.5 and 8.5 clock pulses later depending on the relative timing of the clock and CONVERT signals. Timing diagrams for a conversion are shown in Fig. 2.

The converter is cleared by a low-going CONVERT pulse, which sets the most significant bit and resets all the other bits and the  $\overline{BUSY}$  flag. Whilst the CONVERT input is low the MSB output of the DAC is continuously compared with the analogue input, but otherwise the converter is inhibited.

After the CONVERT input goes high again the MSB decision is made and the successive approximation routine runs to completion.

The CONVERT pulse can be as short as 200ns; however the MSB must be allowed to settle for at least 550ns before the MSB decision is made. To ensure that this criterion is met even with short CONVERT pulses the converter waits, after the CONVERT input goes high, for a rising clock edge followed by a falling clock edge, the MSB decision being taken on the falling clock edge. This ensures that the MSB is allowed to settle for at least half a clock period, or 550ns at maximum clock frequency. The CONVERT input is not locked out during a conversion and if it is pulsed low at any time the converter will restart.

The  $\overline{BUSY}$  output goes high simultaneously with the LSB decision, at the end of a conversion indicating data valid. Note that if the three-state data outputs are enabled during a conversion the valid data will be available at the outputs after the rising edge of the  $\overline{BUSY}$  signal. If, however, the outputs are not enabled until after  $\overline{BUSY}$  goes high then the data will be subject to the propagation delay of the three-state buffers. (See under DATA OUTPUTS).



**CONTINUOUS CONVERSION**

If a free-running conversion is required then the converter can be made to cycle by inverting the BUSY output and feeding it to the CONVERT input. To ensure that the converter starts reliably after power up an initial start pulse is required. This can be ensured by using a NOR gate instead of an inverter and feeding it with a positive going pulse which can be derived from a simple RC network that gives a single pulse when power is applied, as shown in Fig. 3a.

The ADC will complete a conversion on every eighth clock pulse, with the BUSY output going high for a period determined by the propagation delay of the NOR gate, during which time the

data can be stored in a latch. The time available for storing data can be increased by inserting delays into the inverter path.

A timing diagram for the continuous conversion mode is shown in Fig. 3b.

As the  $\overline{\text{BUSY}}$  output uses a passive pull-up the rise time of this output depends on the RC time constant of the pull-up resistor and load capacitance. In the continuous conversion mode the use of a 4k7 external pull-up resistor is recommended to reduce the risetime and ensure that a logic 1 level is reached.

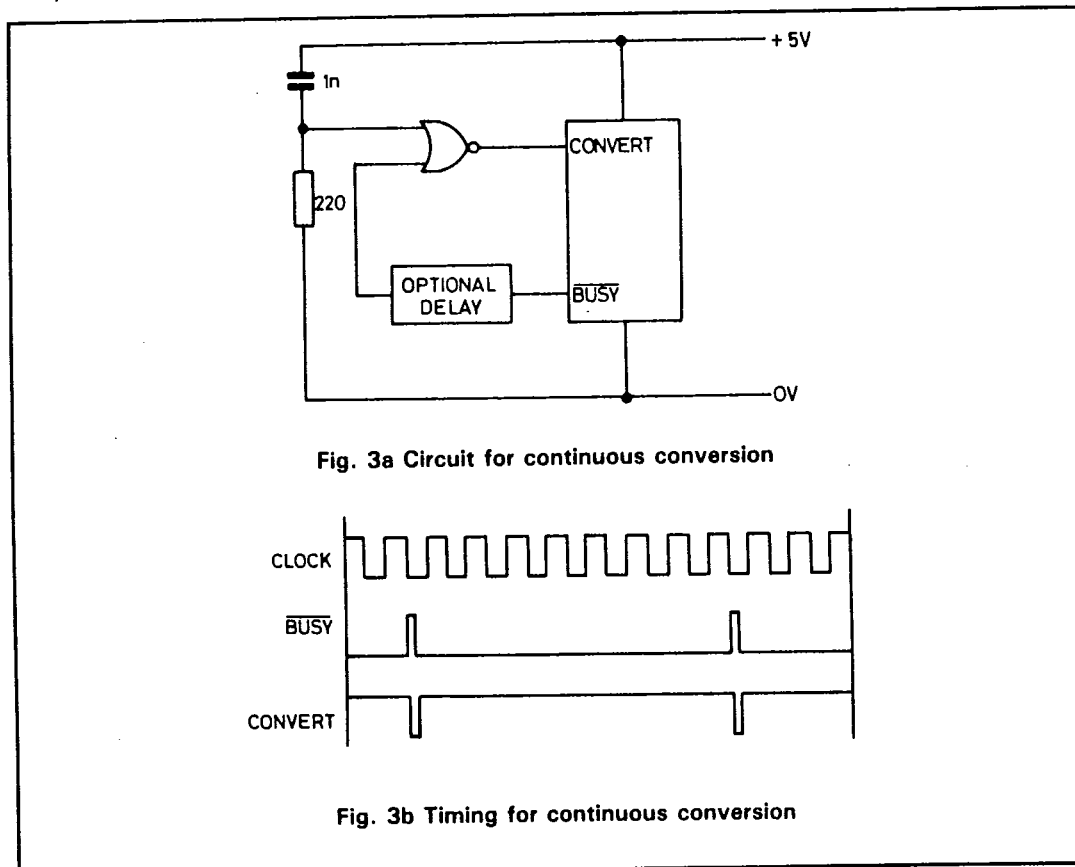

Fig. 3a Circuit for continuous conversion

Fig. 3b Timing for continuous conversion

**DATA OUTPUTS**

The data outputs are provided with three-state buffers to allow connection to a common data bus. An equivalent circuit is shown in Fig. 4. Whilst the  $\overline{\text{RD}}$  input is high both output transistors are turned off and the ZN447 presents only a high impedance load to the bus.

When  $\overline{\text{RD}}$  is low the data outputs will assume the logic states present at the outputs of the successive register.

A test circuit and timing diagram for the output enable/disable delays are given in Fig. 5.

T-51-10-08

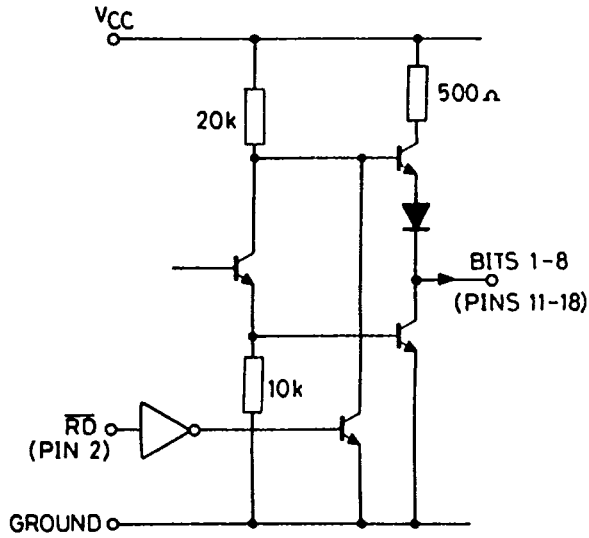
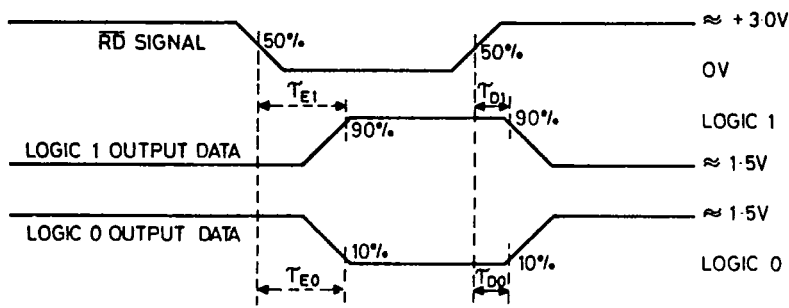

Fig. 4 Data output



OUTPUT LOAD

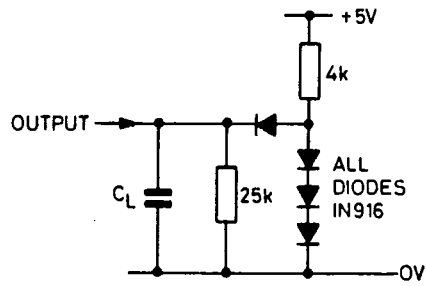

Fig. 5 Output enable/disable delays

**BUSY OUTPUT**

T-51-10-08

The  $\overline{\text{BUSY}}$  output, shown in Fig. 6, utilises a passive pull-up for CMOS/TTL compatibility. This also allows up to four  $\overline{\text{BUSY}}$  outputs to be

wire-ANDed together to form a common interrupt line.

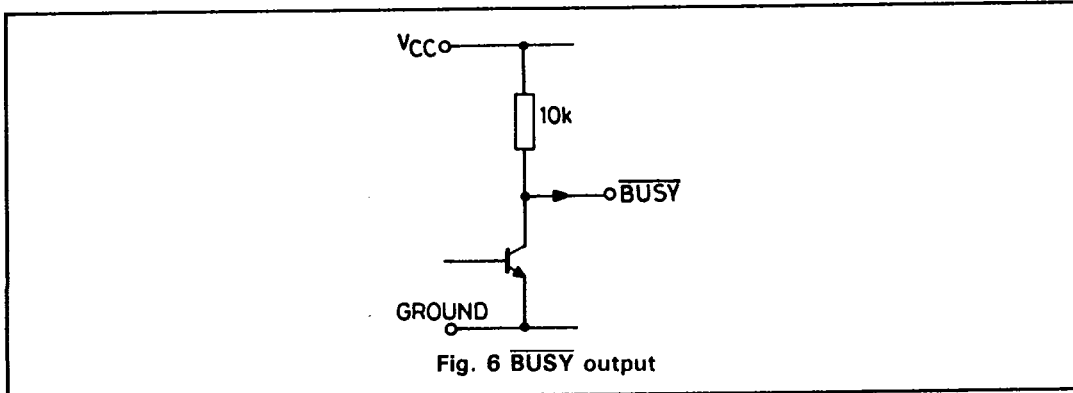

**ON-CHIP CLOCK**

The on-chip clock operates with only a single external capacitor connected between pin 3 and ground as shown in Fig. 7a. A graph of typical oscillator frequency versus capacitance is given in Fig. 8. The oscillator frequency may be trimmed by means of an external resistor in series with the capacitor, as shown in Fig. 7b.

For optimum accuracy and stability of the oscillator frequency without trimming the use of a crystal or ceramic resonator is recommended, as shown in Fig. 7c. The final option is to overdrive the oscillator input with an external clock signal from a TTL or CMOS gate, as shown in Fig. 7d.

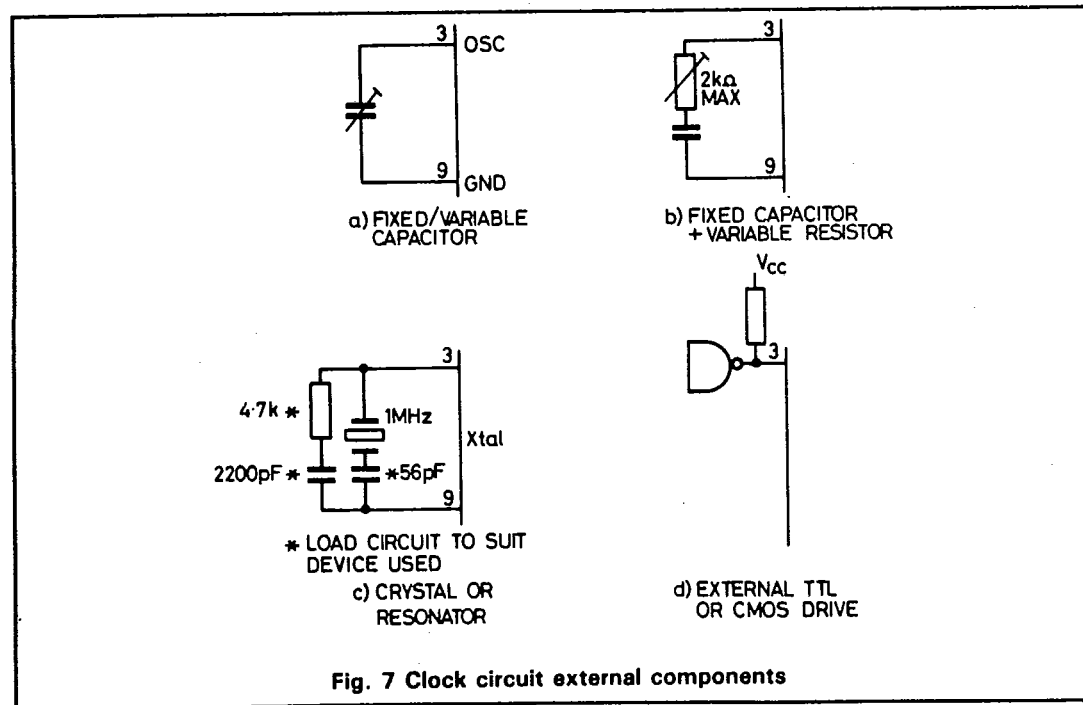



T-51-10-08

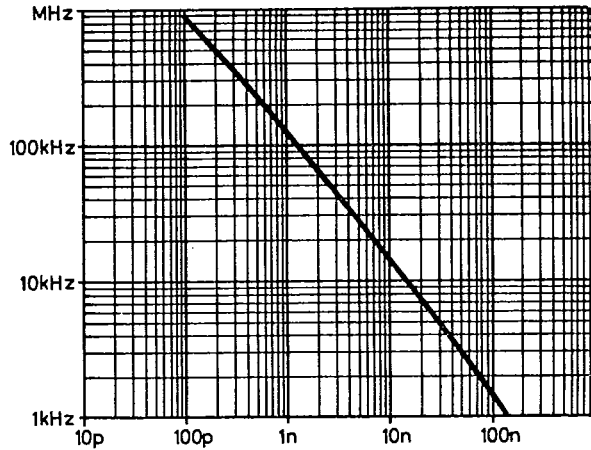

Fig. 8 Typical clock frequency v C<sub>CK</sub> (R<sub>CK</sub> = 0)

**ANALOGUE CIRCUITS**

**D-A converter**

The converter is of the voltage switching type and uses an R-2R ladder network as shown in Fig. 9. Each element is connected to either 0V or V<sub>REF IN</sub> by transistor voltage switches specially designed for low offset voltage (1mV).

A binary weighted voltage is produced at the output of the R-2R ladder.

$$D \text{ to } A \text{ output} = \frac{n}{256} (V_{REF IN} - V_{OS}) + V_{OS}$$

where n is the digital input to the D-A from the successive approximation register.

V<sub>OS</sub> is a small offset voltage that is produced by the device supply current flowing in the package lead resistance. This offset will normally be removed by the setting up procedure and since the offset temperature coefficient is low (8μV/°C) the effect on accuracy will be negligible.

The D-A output range can be considered to be 0 - V<sub>REF IN</sub> through an output resistance R (4k).

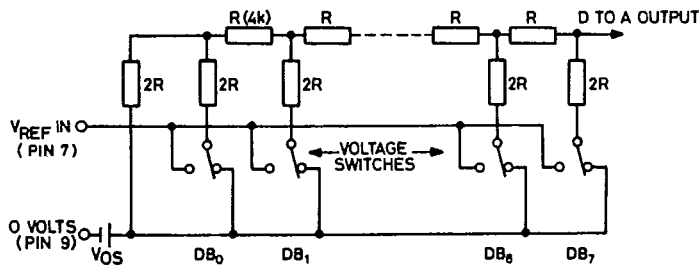

Fig. 9 R-2R ladder network

## REFERENCE

T-51-10-08

## (a) Internal reference

The internal reference is an active bandgap circuit which is equivalent to a 2.5V Zener diode with a very low slope impedance (Fig. 10). A resistor ( $R_{REF}$ ) should be connected between pins 8 and 10.

The recommended value of  $390\Omega$  will supply a nominal reference current of  $(5 - 2.5) / 0.39 = 6.4\text{mA}$ . A stabilising/decoupling capacitor,  $C_{REF}$  ( $4.7\mu$ ), is required between pins 8 and 9. For internal reference operation  $V_{REF OUT}$  (pin 8) is connected to  $V_{REF IN}$  (pin 7).

Up to five ZN447's may be driven from one internal reference, there being no need to reduce

$R_{REF}$ . This useful feature saves power and gives excellent gain tracking between the converters.

Alternatively the internal reference can be used as the reference voltage for other external circuits and can source or sink up to 3mA.

## (b) External reference

If required an external reference voltage in the range +1.5 to +3V may be connected to  $V_{REF IN}$ . The slope resistance of such a reference source should be less than  $\frac{2.5\Omega}{n}$ , where n is the number of converters supplied.

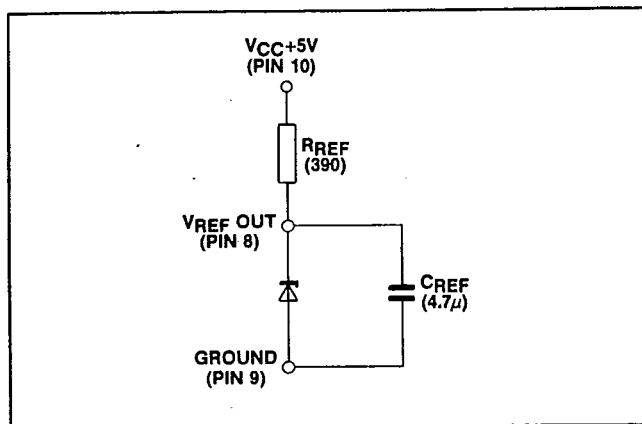

Fig. 10 Internal voltage reference

## RATIOMETRIC OPERATION

If the output from a transducer varies with its supply then an external reference for the ZN447 should be derived from the same supply. The external reference can vary from +1.5 to +3V. The ZN447 will operate if  $V_{REF IN}$  is less than +1.5V but reduced overdrive to the comparator will increase its delay and so the conversion time will need to be increased.

## COMPARATOR

The ZN447 contains a fast comparator, the equivalent input circuit of which is shown in Fig. 11. A negative supply voltage is required to supply the tail current of the comparator. However as this is only 25 to  $150\mu\text{A}$  and need not be well stabilised it can be supplied by a simple diode pump circuit driven from the BUSY output.

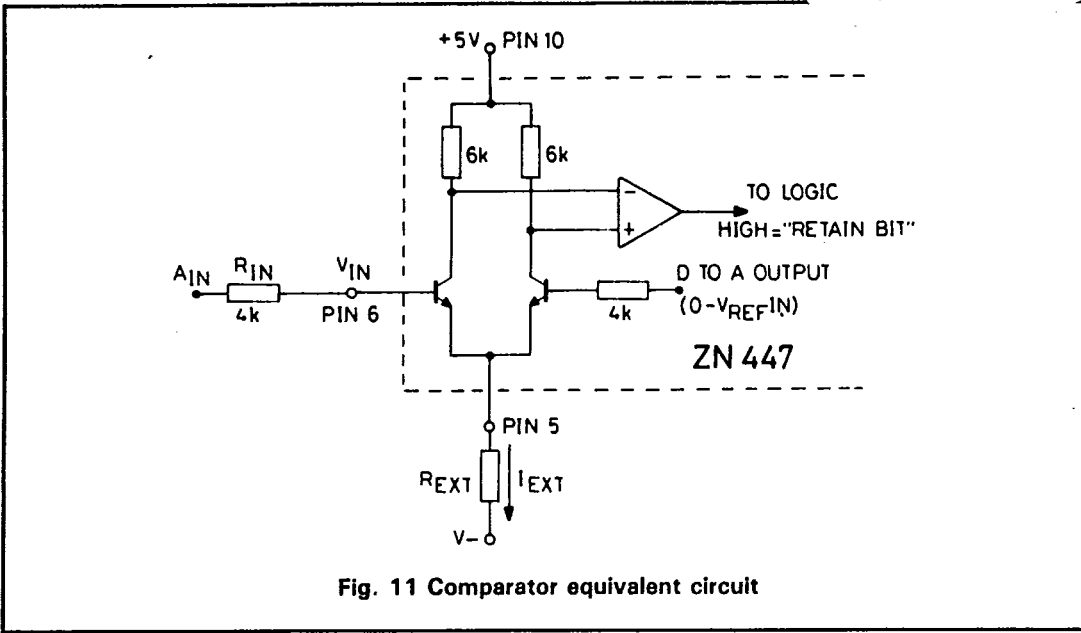

Fig. 11 Comparator equivalent circuit

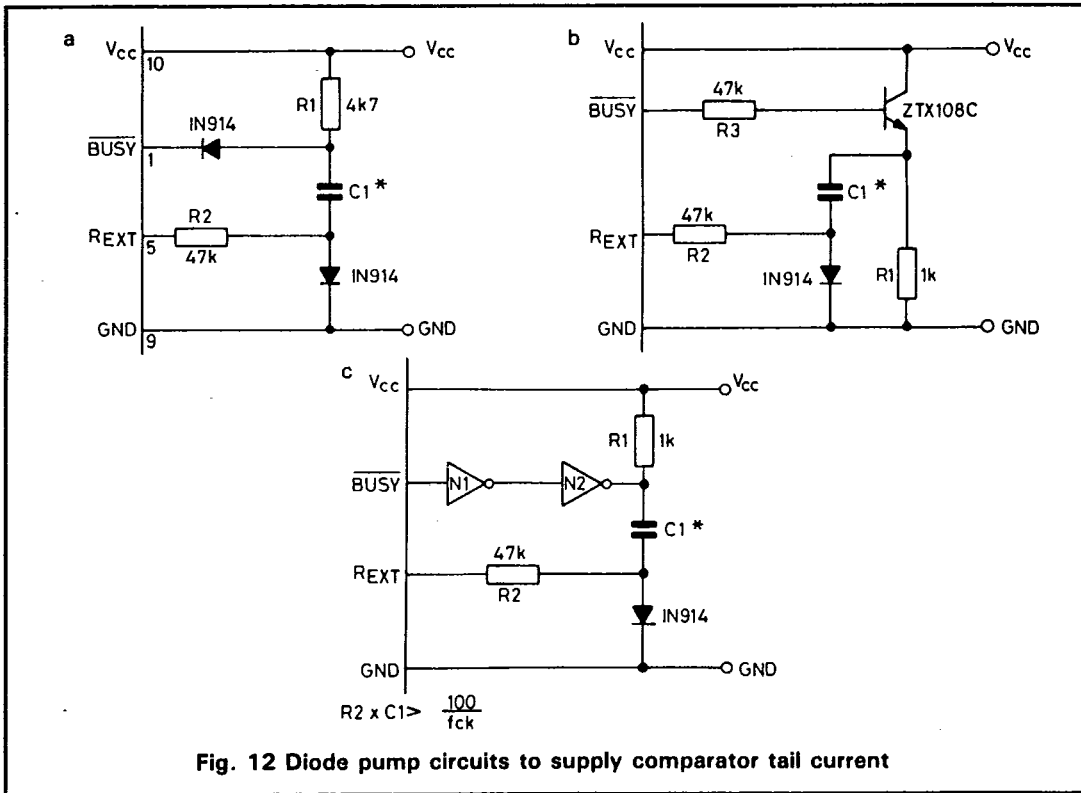

Fig. 12 Diode pump circuits to supply comparator tail current

Several suitable circuits are shown in Fig. 12. The principle of operation is the same in each case. Whilst the BUSY output is high, capacitor C1 is charged to about 4-4.5V. During a conversion the BUSY output goes low and the upper end of C1 is thus also pulled low. The lower end of C1 therefore applies about -4V to R2, thus providing the tail current for the comparator. The time constant R2.C1 is chosen according to the clock frequency so that droop of the capacitor voltage is not significant during a conversion.

The constraint on using this type of circuit is that C1 must be recharged whilst the BUSY output

is high. If the  $\overline{\text{BUSY}}$  output is high for greater than one converter clock period then the circuit of Fig. 12a will suffice. If this is not the case, for example, in the continuous conversion mode, then the circuits of Figs. 12b and 12c are recommended, since these can pump more current into the capacitor.

T-51-10-08

Where several ZN447's are used in a system the self-oscillating diode pump circuit of Fig. 13 is recommended. Alternatively, if a negative supply is available in the system then this may be utilised. A list of suitable resistor values for different supply voltages is given in table 1.

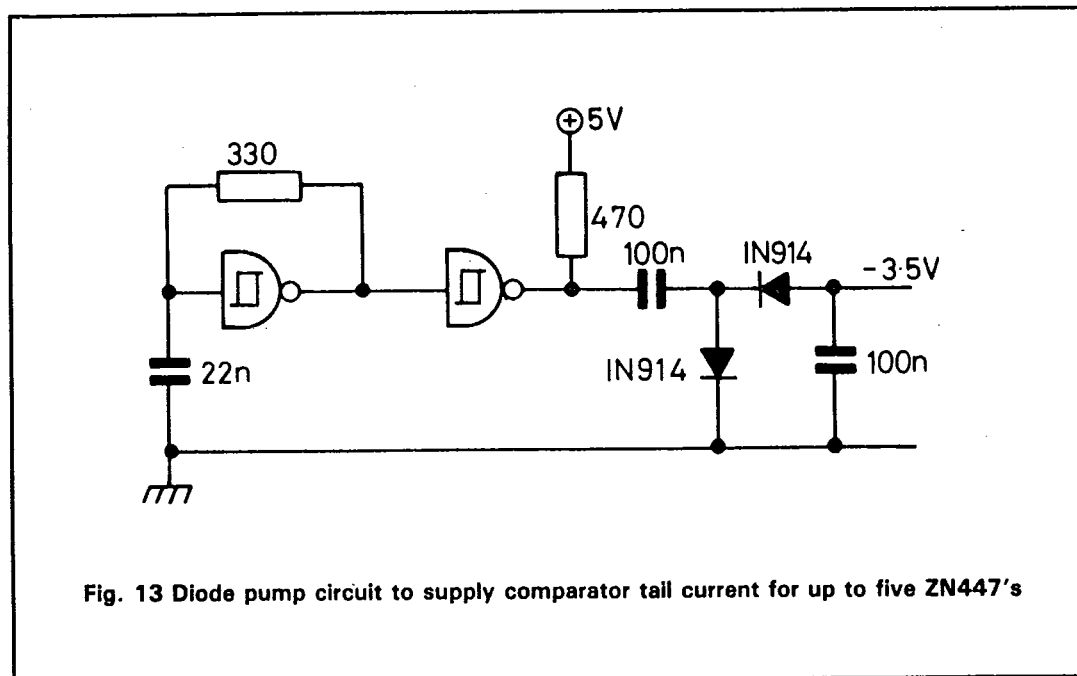

Fig. 13 Diode pump circuit to supply comparator tail current for up to five ZN447's

Table 1

V - (volts)	R <sub>EXT</sub> (kΩ)
3	47
5	82
10	150
12	180
15	220
20	330
25	390
30	470

ZN447/8/9

T-51-10-08

**ANALOGUE INPUT RANGES**

The basic connection of the ZN447 shown in Fig. 14 has an analogue input range 0 to  $V_{REF IN}$  which, in some applications, may be made available from previous signal conditioning/scaling circuits. Input voltage ranges greater than this are accommodated by providing an attenuator on the comparator input, whilst for

smaller input ranges the signal must be amplified to a suitable level.

Bipolar input ranges are accommodated by off-setting the analogue input range so that the comparator always sees a positive input voltage.

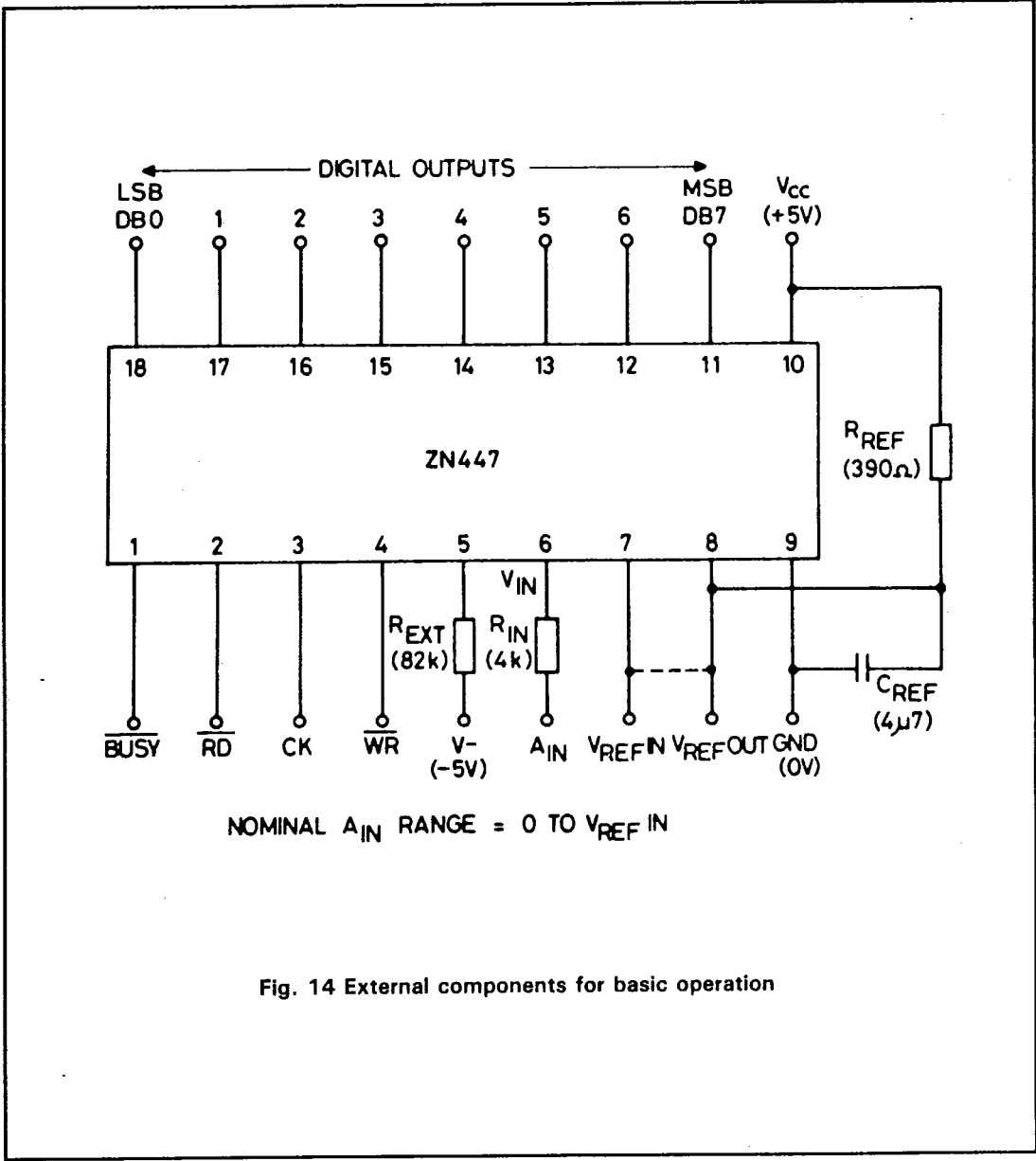

Fig. 14 External components for basic operation

T-51-10-08

**UNIPOLAR OPERATION**

The general connection for unipolar operation is shown in Fig. 15.

The values of  $R_1$  and  $R_2$  are chosen so that  $V_{IN} = V_{REF IN}$  when the Analogue Input ( $A_{IN}$ ) is at full-scale.

The resulting full-scale range is given by

$$A_{IN FS} = (1 + \frac{R_1}{R_2}), V_{REF IN} = G \cdot V_{REF IN}$$

To match the ladder resistance  $R_1/R_2$  ( $R_{IN}$ ) = 4k.

The required nominal values of  $R_1$  and  $R_2$  are given by  $R_1 = 4G k$ ,  $R_2 = \frac{4G}{G-1} k$

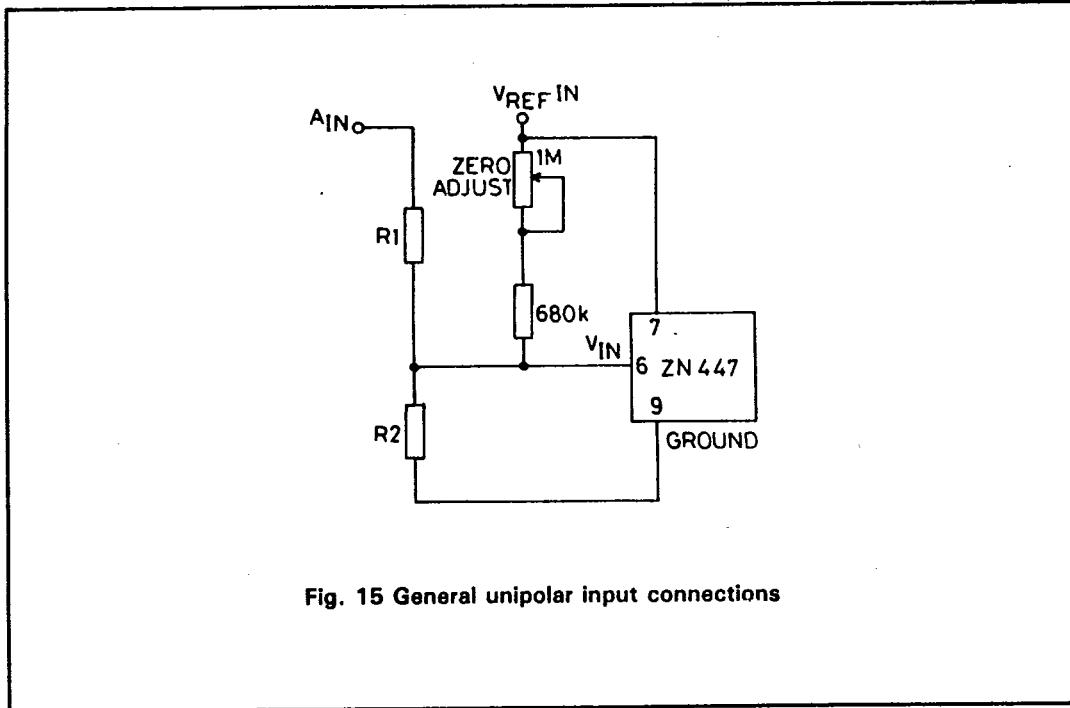

Fig. 15 General unipolar input connections

Using these relationships a table of nominal values of  $R_1$  and  $R_2$  can be constructed for  $V_{REF IN} = 2.5V$ .

Input range	G	$R_1$	$R_2$
+5V	2	8k	8k
+10V	4	16k	5.33k

**Gain adjustment**

Due to tolerances in  $R_1$  and  $R_2$ , tolerances in  $V_{REF}$  and the gain (full-scale) error of the DAC, some adjustment should be incorporated into  $R_1$  to calibrate the full-scale of the converter. When used with the internal reference and 2% resistors a preset capable of adjusting  $R_1$  by at least  $\pm 5\%$  of its nominal value is suggested.

**Zero adjustment**

Due to offsets in the DAC and comparator the zero (0 to 1) code transition would occur with typically 15mV applied to the comparator input, which corresponds to 1.5LSB with a 2.56V reference.

Zero adjustment must therefore be provided to set the zero transition to its correct value of +0.5LSB or 5mV with a 2.56V reference. This is achieved by applying an adjustable positive offset to the comparator input via P2 and R3. The values shown are suitable for all input ranges greater than 1.5 times  $V_{REF IN}$ .

Practical circuit values for +5 and +10V input ranges are given in Fig. 16, which incorporates both zero and gain adjustments.

T-51-10-08

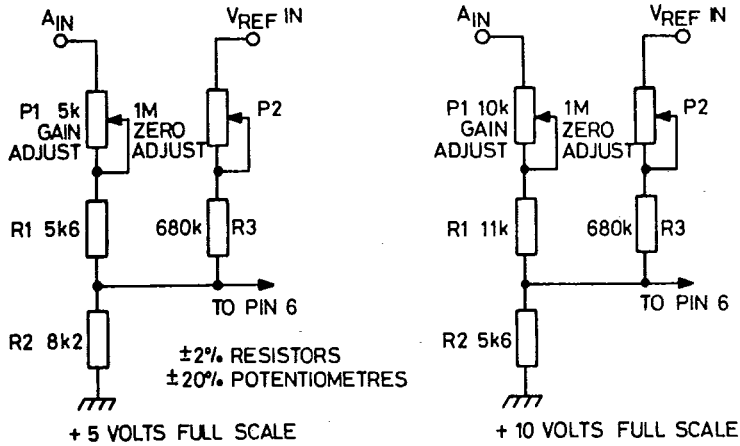

Fig. 16 Unipolar component values

**Unipolar adjustment procedure**

- (i) Apply continuous convert pulses at intervals long enough to allow complete conversion and monitor the digital outputs.
- (ii) Apply full-scale minus 1.5LSB to  $A_{IN}$  and adjust gain until bit 8 (LSB) output just flickers between 0 and 1 with all other bits at 1.
- (iii) Apply 0.5LSB to  $A_{IN}$  and adjust zero until bit 8 just flickers between 0 and 1 with all other bits at 0.

**Unipolar setting up points**

Input range, +FS	0.5LSB	FS - 1.5LSB
+5V	9.8mV	4.9707V
+10V	19.5mV	9.9414V

$$1\text{LSB} = \frac{\text{FS}}{256}$$

**Unipolar logic coding**

Analogue input ( $A_{IN}$ ) (Nominal code centre value)	Output code (Binary)
FS - 1LSB	11111111
FS - 2LSB	11111110
0.75FS	11000000
0.5FS + 1LSB	10000001
0.5FS	10000000
0.5FS - 1LSB	01111111
0.25FS	01000000
1LSB	00000001
0	00000000

**BIPOLAR OPERATION**

For bipolar operation the input to the ZN447 is offset by half full-scale by connecting a resistor

resistor  $R_3$  between  $V_{REF IN}$  and  $V_{IN}$  (Fig. 17).

T-51-10-08

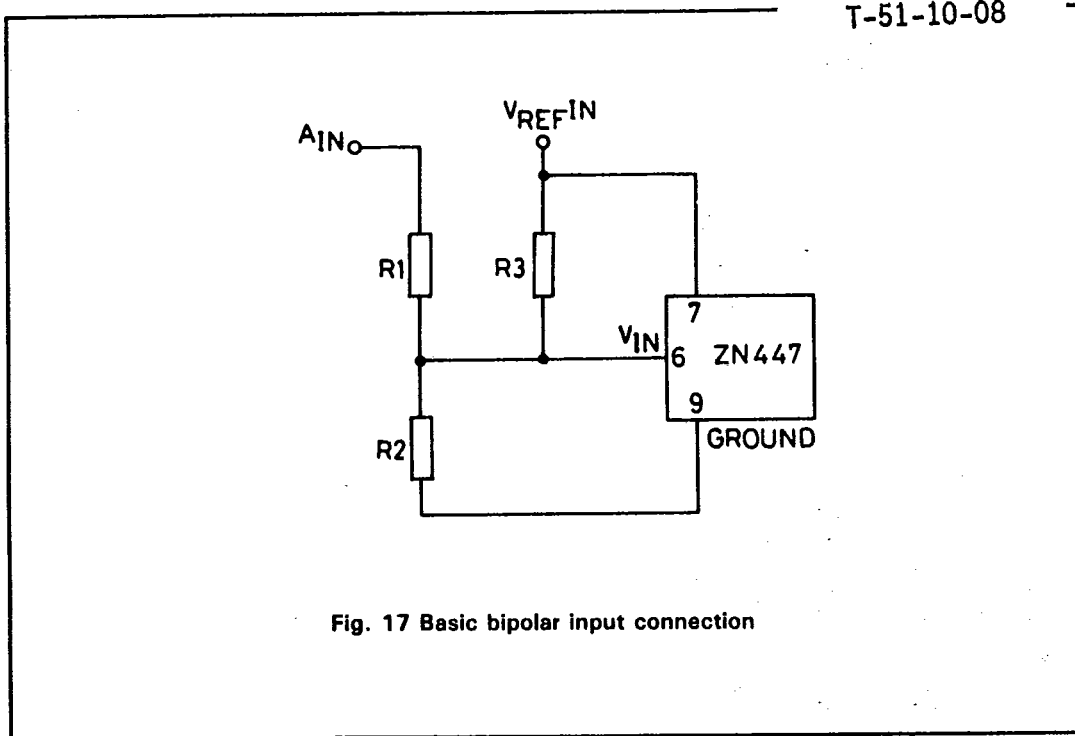

Fig. 17 Basic bipolar input connection

When  $A_{IN} = -FS$ ,  $V_{IN}$  needs to be equal to zero.

When  $A_{IN} = +FS$ ,  $V_{IN}$  needs to be equal to  $V_{REF IN}$ .

If full-scale range is  $\pm G \cdot V_{REF IN}$  then  $R_1 = (G - 1) \cdot R_2$  and  $R_1 = G \cdot R_3$  fulfil the required conditions.

To match the ladder resistance,  $R_1/R_2/R_3 (=R_{IN}) = 4k$ .

Thus the nominal values of  $R_1, R_2, R_3$  are given by  $R_1 = 8 Gk, R_2 = 8G/(G - 1)k, R_3 = 8k$ .

A bipolar range of  $\pm V_{REF IN}$  (which corresponds to the basic unipolar range 0 to  $+V_{REF IN}$ ) results if  $R_1 = R_3 = 8k$  and  $R_2 = \infty$ .

Assuming that  $V_{REF IN} = 2.5V$  the nominal values of resistors for  $\pm 5$  and  $\pm 10V$  input ranges are given in the following table.

Input range	G	$R_1$	$R_2$	$R_3$
$\pm 5V$	2	16k	16k	8k
$\pm 10V$	4	32k	10.66k	8k

Minus full-scale (offset) is set by adjusting  $R_1$  about its nominal value relative to  $R_3$ . Plus full-scale (gain) is set by adjusting  $R_2$  relative to  $R_1$ .

Practical circuit realisations are given in Fig. 18.

Note that in the  $\pm 5V$  case  $R_3$  has been chosen as 7.5k (instead of 8.2k) to obtain a more symmetrical range of adjustment using standard potentiometers.



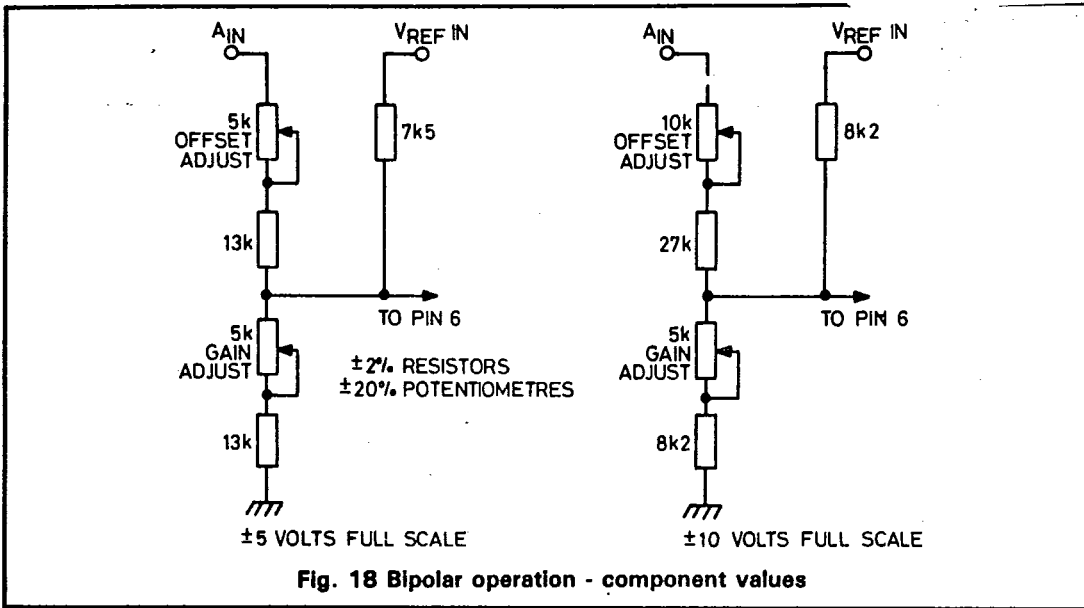

Fig. 18 Bipolar operation - component values

**Bipolar adjustment procedure**

- (i) Apply continuous SC pulses at intervals long enough to allow a complete conversion and monitor the digital outputs.
- (ii) Apply  $-(FS - 0.5LSB)$  to  $A_{IN}$  and adjust offset until the bit 8 (LSB) output just flickers between 0 and 1 with all other bits at 0.
- (iii) Apply  $+(FS - 1.5LSB)$  to  $A_{IN}$  and adjust gain until bit 8 just flickers between 0 and 1 with all other bits at 1.
- (iv) Repeat step (ii).

**Bipolar setting up points**

Input range, $\pm FS$	$-(FS - 0.5LSB)$	$+(FS - 1.5LSB)$
$\pm 5V$	-4.9805V	+4.9414V
$\pm 10V$	-9.9609V	+9.8828V

$$1LSB = \frac{2FS}{256}$$

**Bipolar logic coding**

Analogue input ( $A_{IN}$ ) (Nominal code centre value)	Output code (Offset binary)
$+(FS - 1LSB)$	11111111
$+(FS - 2LSB)$	11111110
$+0.5FS$	11000000
$+1LSB$	10000001
0	10000000
$-1LSB$	01111111
$-0.5FS$	01000000
$-(FS - 1LSB)$	00000001
$-FS$	00000000